

SAL-910G/920G

"Standard" Separate-vacuum Hopper Loader

Date: Feb., 2021

Version: Ver.A



Content

1. General Description	5
1.1 Coding Principle.....	6
1.2 Features.....	6
1.3 Technical Specifications	8
1.3.1 External Dimension	8
1.3.2 Specification	9
1.3.3 Loading Capacity.....	11
1.4 Safety Regulations.....	11
1.4.1 Safety Signs and Labels.....	11
2. Structure Characteristics and Working Principle.....	13
2.1 Working Principle	13
2.2 Options	14
2.3 Options	14
3. Installation Layout.....	15
3.1 Installation and Positioning	15
3.2 Power Connection.....	15
3.3 Compressed Air Connection	16
3.4 Installation diagram.....	17
3.5 Installation Steps.....	18
3.6 Shut-off Suction Box	19
3.7 Installation with the Cyclone Dust Collector ACF-1	19
4. Operation	21
4.1 Panel Description.....	21
4.2 Operation Description	22
4.3 Parameter Description	22
4.3.1 Individual Parameters (hopper)	22
4.3.2 Comm. Parameters (Overall Unit)	23
4.3.3 Communication Parameter Setting.....	25
4.4 Code Description	25
4.5 Action Description	25
4.6 Communication Parameter Table (Protocol modbus –RTU).....	27

5. Troubleshooting	30
6. Maintenance	31
6.1 Hopper Cleaning(Take SVH as an example)	31
6.2 Main Body Cleaning.....	32

Table Index

Table 1-1: SMH Specification	8
Table 1-2: SVH-L Specification	9
Table 1-3: Specification	10
Table 2-1: ACF Specification.....	14

Picture Index

Picture 1-1: SMH External Dimension	8
Picture 1-2: SVH External Dimension.....	8
Picture 1-3: SHR External Dimension.....	9
Picture 1-4: SAL-910G External Dimension	9
Picture 1-5: Loading Capacity	11
Picture 2-1: Working Principle	13
Picture 2-2: ACF External Dimension.....	14
Picture 3-1: Air Suction Inlet.....	17
Picture 3-2: Installation Layout 1	17
Picture 3-3: Installation Layout 2	18
Picture 3-4: Installation Layout 3	18
Picture 3-5: Suction Box Wiring Points	19
Picture 3-6: ACF Installation Diagram	20
Picture 6-1: Hopper Cleaning	31
Picture 6-2: Filter Barrel Cleaning Diagram	32

1. General Description



Please read through this operation manual before using and installation to avoid damage of the machine and personal injuries.



Model: SAL-900G

1.1 Coding Principle

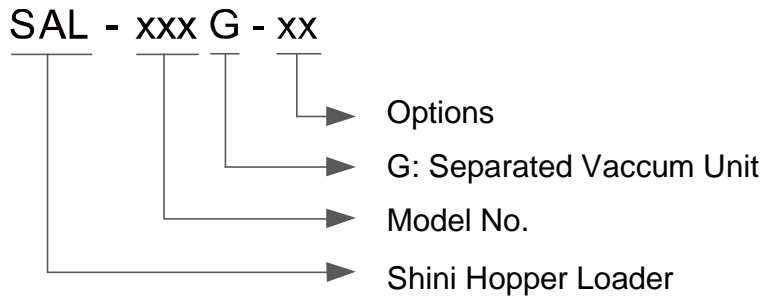

1.2 Features

- Motor overheat protector that can increase the service life.
- Shortage alarm informs the customer to troubleshoot.
- The filter barrel adopts PC (polycarbonate) that is easy to check the dust in the barrel for cleaning.
- The loader equips with RS485 interface for information exchange, which is controlled by central integrator.
- SAL-910G/920G has two-stage conveying function.

All maintenance work should be carried out by a person with technical training or corresponding professional experience. The manual contains instructions for both operating and maintenance. Chapter 6 contains maintenance instructions for service engineers. Other chapters contain instructions for the daily operator.

Any modifications of the machine must be approved by SHINI in order to avoid personal injury and damage to machine. We shall not be liable for any damage caused by unauthorized change of the machine.

Our company provides after-sales service. Should you have any problem during using the machine, please contact the company or the local vendor.

Headquarter and Taipei factory:

Tel: + 886 (0)2 2680 9119

Shini Plastics Technologies (Dongguan), Inc:

Tel: + 86 (0)769 8111 6600

Email: shini@shini.com

Shini Plastics Technologies India Pvt.Ltd.:

Tel: + 91 250 3021 166.

1.3 Technical Specifications

1.3.1 External Dimension

SMH

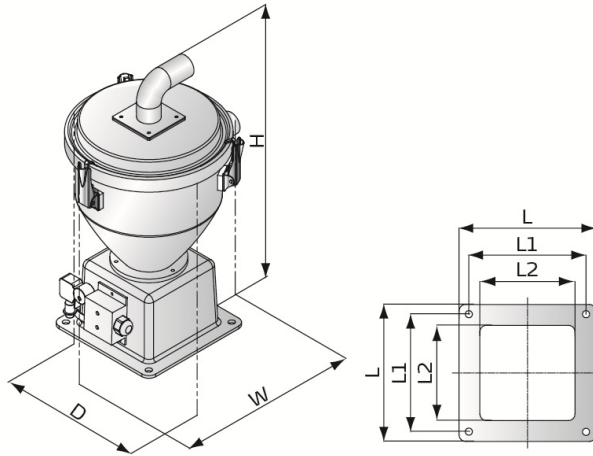

Picture 1-1: SMH External Dimension

Table 1-1: SMH Specification

Model	L(mm)	L1(mm)	L2(mm)
SMH-6L	210	180	148
SMH-12L			

SVH

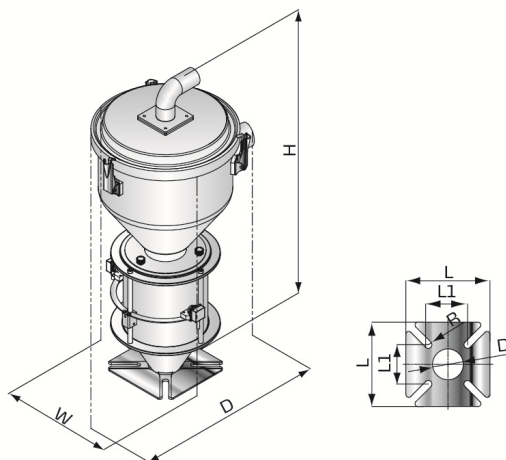

Picture 1-2: SVH External Dimension

Table 1-2: SVH-L Specification

Models	L(mm)	L1(mm)	D(mm)	R(mm)
SVH-6L	150	70	55	6.5
SVH-12L	180	80	55	6.5

SHR

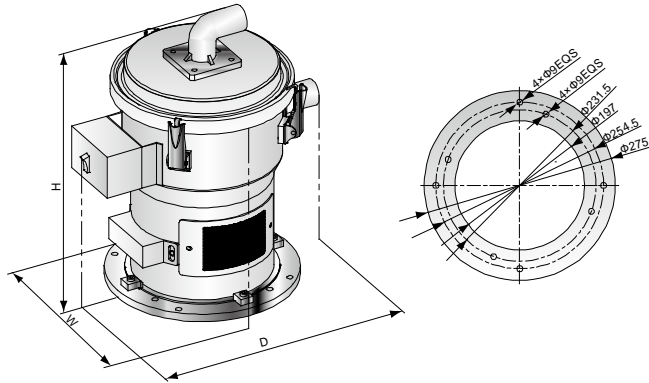

Picture 1-3: SHR External Dimension

SAL-910G (Main controller)

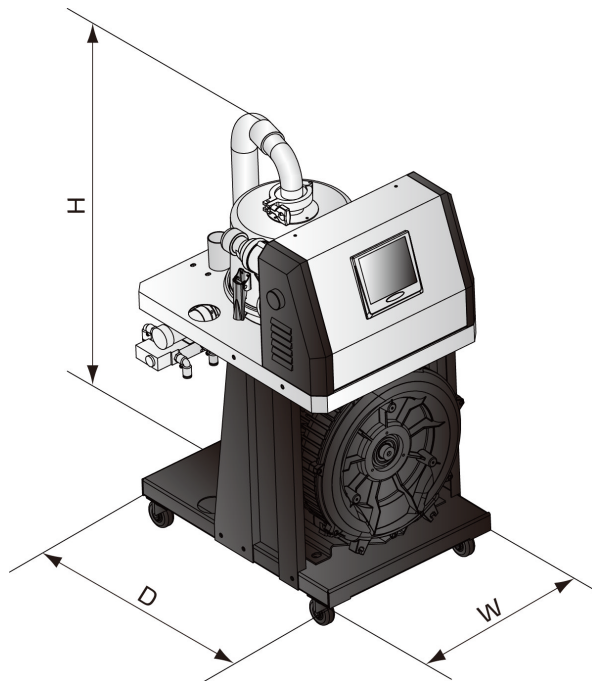

Picture 1-4: SAL-910G External Dimension

1.3.2 Specification

Table 1-3: Specification

Model	Ver.	Main Unit				Hopper Receiver(s)				RS-485 communication function	Conveying Hose Dia. (Inch)	Air Suction Pipe Dia. (Inch)	Conveying Capacity (50/60Hz) (kg / hr)
		Motor Type	Motor Power (kW) (50/60Hz)	Dimensions (mm)H×W×D	Weight (kg)	Recommended Model	Hopper Capacity (L)	Dimensions (mm) H×W×D	Weight (kg)				
SAL-910G	A	Induction	0.75(3Φ)	500×395×800	44	1×SMH-6L	6	460×260×315	6	●	1.5	1.5	500/ 760
						1×SVH-6L		600×285×305	7				
						2×SMH-6L		460×260×315	11				
						2×SVH-6L		600×285×305	7				
SAL-920G	A	Induction	1.5(3Φ)	500×395×800	44	1×SMH-12L	12	515×300×350	7	●	1.5	1.5	680/ 960
						1×SVH-12L		695×300×360	11				
						2×SMH-12L		515×300×350	7				
						2×SVH-12L		695×300×360	11				

Notes: 1) "SVH" stands for photosensor hopper receiver; "SMH" stands for vacuum hopper receiver. "SHR-U" stands for Euro-Hopper receiver.

2) Test condition of conveying capacity: Plastic material of bulk density 0.65kg/L, dia. 3~5 mm, vertical conveying height: 4m, horizontal conveying distance: 5m.

3) "●" stands for standard, "○" stands for options, "-" stands for none.

4) Adopt the 4P heavy-duty connector.

5) Power supply: 3Φ, 400VAC, 50Hz.

1.3.3 Loading Capacity

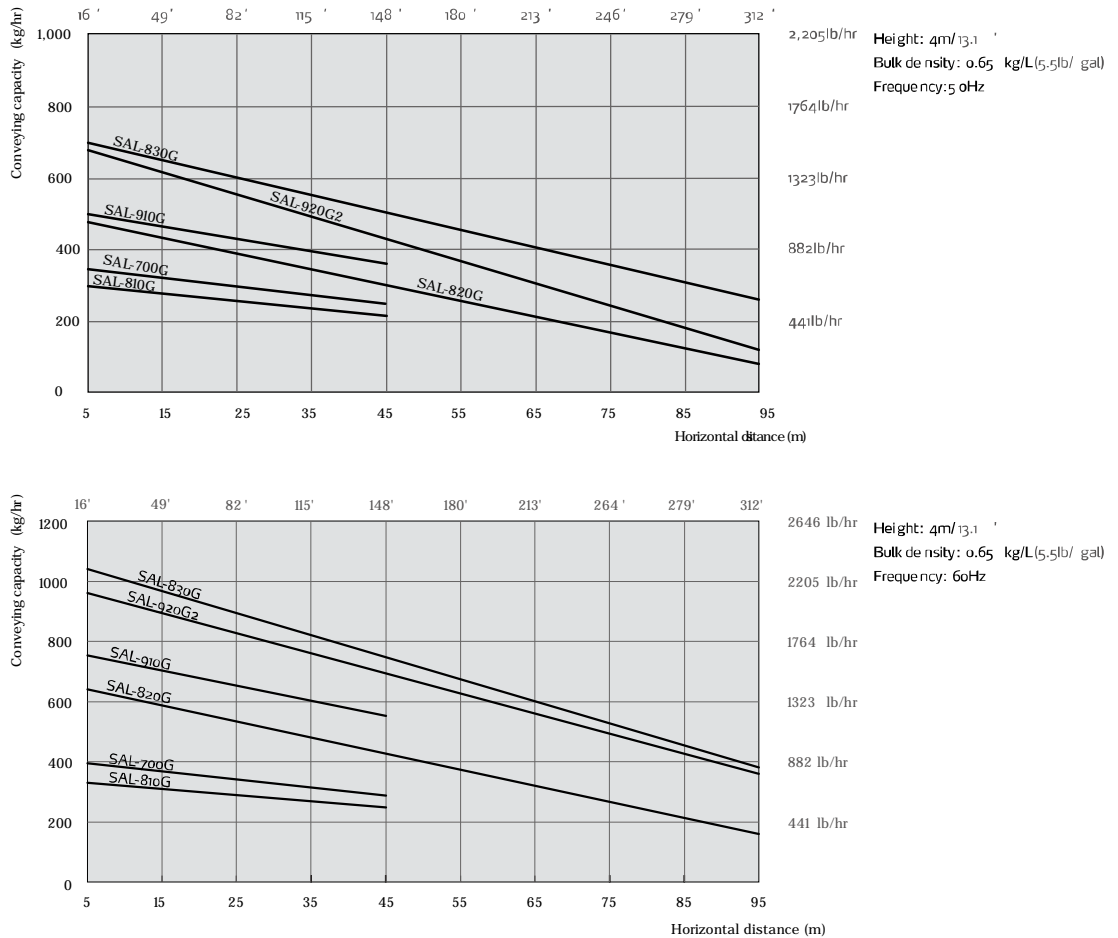

Picture 1-5: Loading Capacity

1.4 Safety Regulations

Please abide by the safety guide when you operate the machine so as to prevent damage of the machine and personal injuries.

1.4.1 Safety Signs and Labels



All electrical components should be installed by qualified electricians. Turn off main switch and control switch during repair and maintenance.



Warning! High voltage!
This mark is attached on the cover of the control box.



Warning! Be careful!

Be more careful when this mark appears.



Attention!

No need for regular inspection because all the electrical parts in the control unit are fixed tightly!

2. Structure Characteristics and Working Principle

2.1 Working Principle

SAL-910G series are suitable for conveying plastic granules over long distance. Utilizing high efficiency vacuum blower to produce vacuum in material hopper, plastic materials will then be fed into material hopper by air pressure.

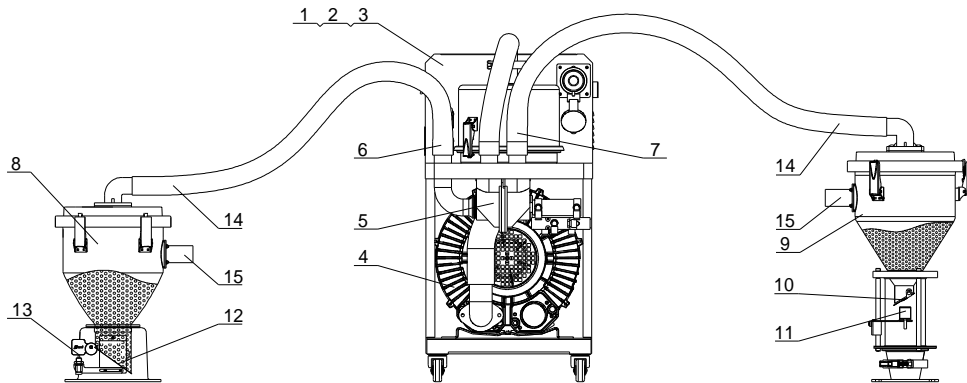

Picture 2-1: Working Principle

- | | |
|-------------------------|-------------------------|
| 1. Control box | 2. Buzzer |
| 3. Power switch | 4. High-pressure blower |
| 5. Three way valve | 6. Air suction inlet 1 |
| 7. Air suction inlet 2 | 8. Hopper 1 |
| 9. Hopper 2 | 10. Discharging plate1 |
| 11. Photosensor | 12. Discharging plate2 |
| 13. Microswitch | 14. Hopper suction pipe |
| 15. Material inlet pipe | |

Turn on the power switch (3), and set the suction time of hopper 1 (8) and hopper 2 (9) on the touch panel. Press the start button, the high pressure blower (4) works, the three-way valve (5)'s control suction inlet 1 (6) opens, the suction inlet 2 (7) and discharge plate 1 (10) close, and the hopper 2 (9) begins to suck the materials. After suction, the high pressure blower (4) stops running, and the materials in hopper 2(9) drop because of the gravity. When the micro switch (13) detected no material in hopper 1 (8), the high pressure blower (4) works. At this

time, the solenoid valve switches, the three-way valve's control suction inlet 2 (7) opens, the discharge plate 2 (12) closes and the hopper 1 (8) starts to suck the materials. After suction, if the photosensor switch (11) detected no materials in hopper 2 (9), the high pressure blower (4) will start to suck materials again by switching the solenoid valve, and so on. When no materials can be sucked or in shortage, the buzzer (2) on the control box (1) will alarm.

2.2 Options

- Cyclone dust collector

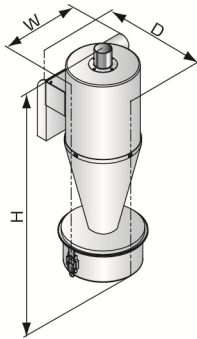

It is suggested to opt cyclone dust collector to reduce cleaning times of filter when regrind material occupies over 30% of total raw material.

Table 2-1: ACF Specification

Model	H×W×D	Pipe diameter (inch)
ACF-1	550×220×235	1.5

Picture 2-2: ACF External Dimension

- For SHR,SCH-6U/12U/24U and SICH-6U/12U/24U are optional (Temperature reduction is below 30°C within 30min).
- SMH can be matched with SCH-12U/24U to facilitate the temporary storage of materials.

2.3 Options

- For polished hopper inside ones, add "P" at the end of model code.

3. Installation Layout

3.1 Installation and Positioning

- 1) Machine just can be mounted in vertical position. Make sure there's no pipe, fixed structure or other objects above the installing location and around the machine which may block machine's installation, hit objects or injure human person.
- 2) For easy maintenance, it's suggested to leave 1m space around the machine.
- 3) Machine should be placed on water-level surface. If it needs to be mounted on a higher surface (e.g. the scaffold or the interlayer), should ensure its structure and size could bear the weight and size of the machine.

3.2 Power Connection

- 1) Make sure the voltage and frequency of the power source comply with those indicated on the manufacturer nameplate that attached to the machine.
- 2) Power cable and earth connection should conform to your local regulations.
- 3) Use independent electrical wires and power switch. Diameter of electrical wire should not be less than those used in the control box.
- 4) The power cable connection terminals should be tightened securely.
- 5) The machine requires 3-phase 3-wire power source, connect the power lead (L1, L2, L3) to the live wires, and the earth (PE) to the ground.
- 6) Power supply requirements:
Main power voltage: +/- 5%
Main power frequency: +/- 2%
- 7) ***Please refer to electrical drawing of each model to get the detailed power supply specifications***

3.3 Compressed Air Connection

Table 3-1: Compressed Air Specification

Items	Range	Remarks
Quality Grade	335	According to GB/T 13277-1991, the concentration of solid particles is not more than 5mg/m ³ , the temperature of dew point is about - 20 °C, and the oil content is not more than 25mg/m ³ .
Air Source Pressure (bar)	3~5	--
Air Flow (L/hr)	~10	--
Pipe Size	PM20	Quick connector

3.4 Installation diagram

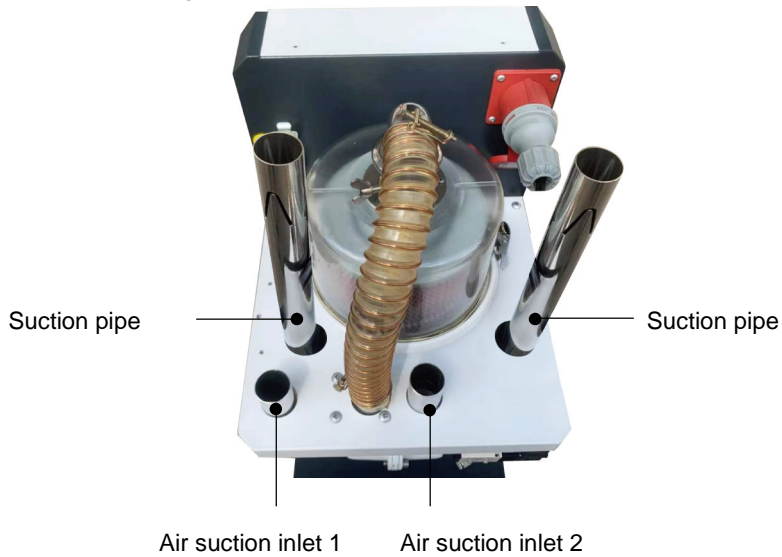

Picture 3-1: Air Suction Inlet

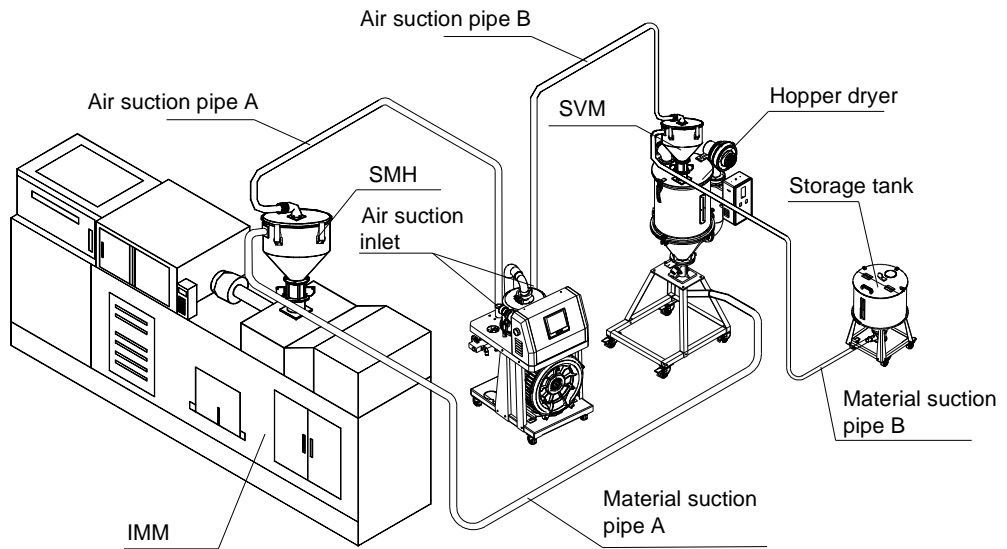

Picture 3-2: Installation Layout 1

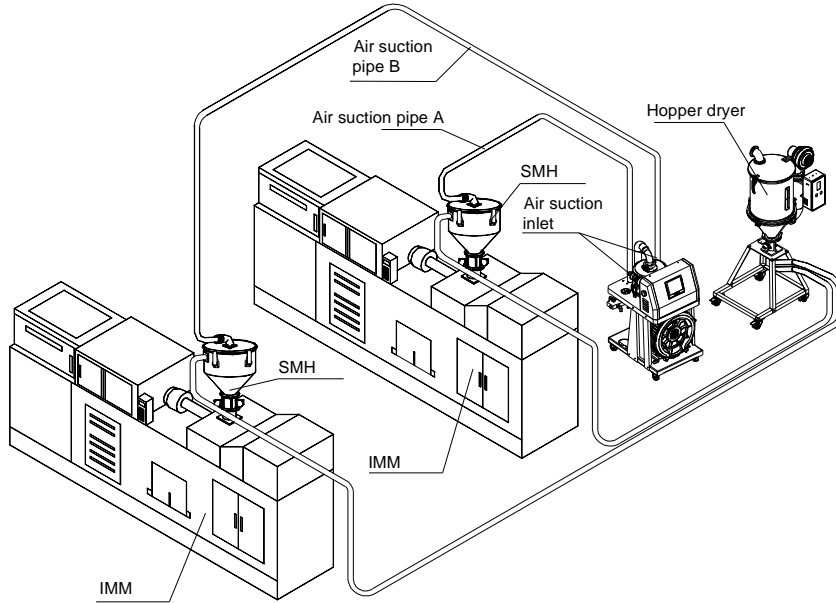

Picture 3-3: Installation Layout 2

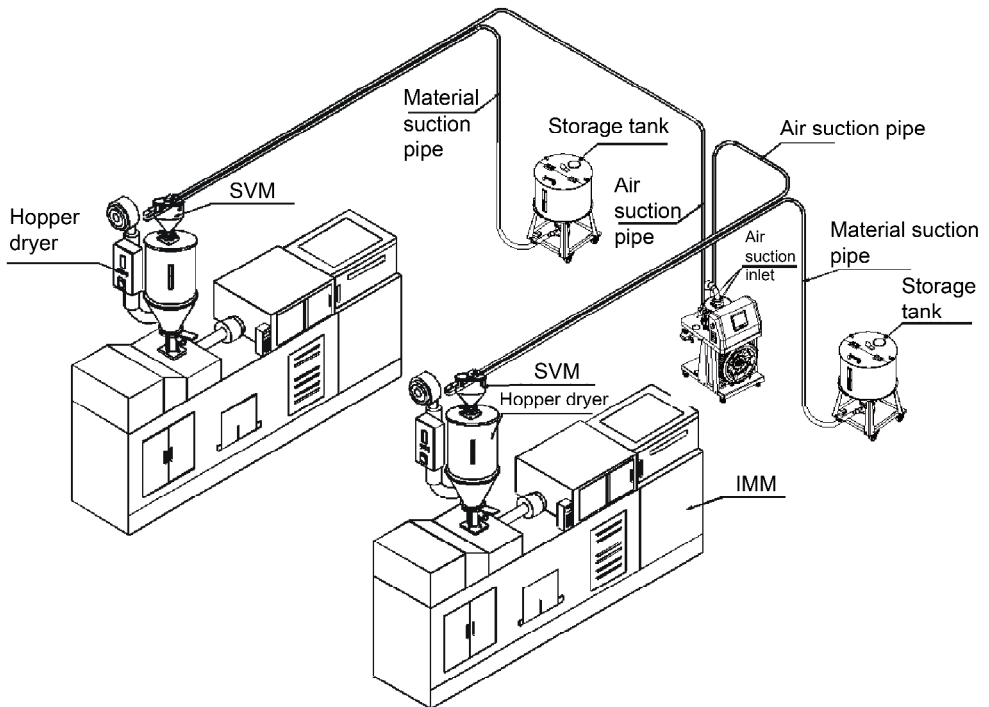

Picture 3-4: Installation Layout 3

3.5 Installation Steps

- 1) Place the SAL-910G/920G2 in proper place
- 2) Install the photosensor hopper receiver and vacuum hopper receiver, and connect the signal wire to the loader SAL-910G/920G2.
- 3) Connect the photosensor hopper suction inlet and vacuum hopper suction inlet to corresponding suction inlet of loader SAL-900G/900G2 with the steel wire hose, and connect the vacuum hopper suction inlet and photosensor hopper suction inlet to the suction box (usually under the dryer or storage hopper).

3.6 Shut-off Suction Box

The shut-off valve is linked with the photosensor hopper receiver. When the photosensor hopper receiver sucks materials, the shut-off valve will open for a period of time (adjustable) and close immediately. Then, the loader will continue to suck materials till all materials in the suction pipe are getting into the photosensor hopper receiver.

- 1) Connect the signal line of the connection point on the suction box to the signal connection point of the host shut-off valve.
- 2) Connect the suction box's suction inlet and hopper's feed port with the steel wire hose.

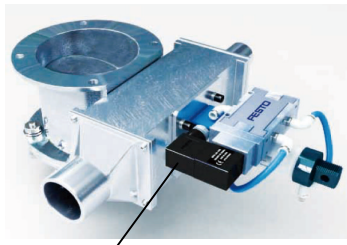

Connection point



Shut-off valve signal
connection point

Picture 3-5: Suction Box Wiring Points

3.7 Installation with the Cyclone Dust Collector ACF-1

- 1) Find the installation hole as shown in below Picture 3-6.

- 2) Remove the bolts.
- 3) Install the ACF-1 on the cover plate of SAL-G and locked with screws.
- 4) Connect the suction inlet of SAL-G's host unit and ACF-1's exhaust outlet with the steel wire hose.
- 5) Connect the ACF-1's air inlet and hopper's suction inlet with the steel wire hose.

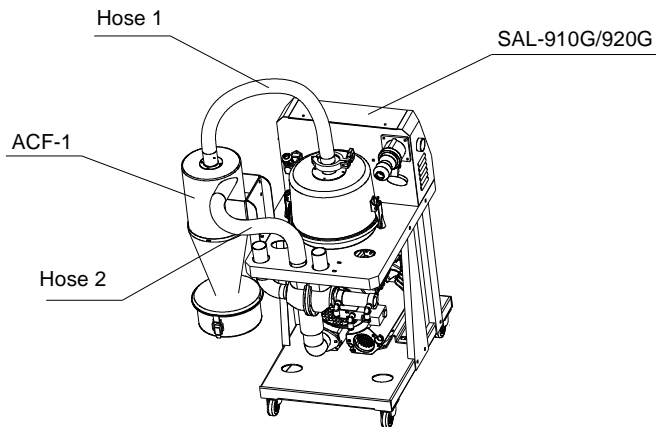

Hose 1 connect the cyclone dust collector ACF-1 and
hopper loader SAL-910G/920G
Hose 2 connects to the hopper's air suction pipe

Picture 3-6: ACF Installation Diagram

4. Operation

4.1 Panel Description

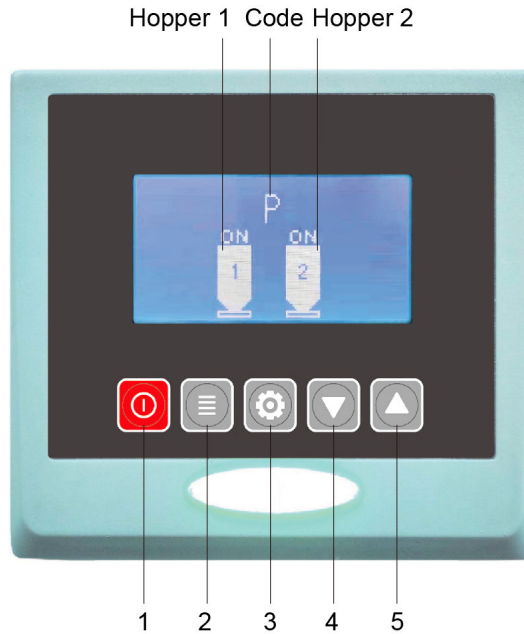

Picture 4-1: Control Panel

Table 4-1: Press Button Description

NO.	Symbol	Name	Meaning	Description
1		ON/OFF	Startup /shutdown	Start/stop the machine
2		MENU	Menu	Enter or exit parameter setting
3		SET	Setting	Modify or confirm machine parameters
4		DOWN	Down key	Move the menus down, and reduce the value
5		UP	Up key	Move the menus up, and increase the value

4.2 Operation Description

After power on, press the < ON/OFF > key to start the machine and the hopper loader starts to work. Then, press the <ON/OFF> key again to stop the machine;

Setting

For example: In the OFF state, set the suction time to 15s, and press <Menu > key to select the "Individual Parameters" and press <SET> key to enter in. Then, select the hopper 1 and the "Suction Time", and press < SET > key to enter. Next, press the <DOMN> or <UP>key to adjust the value to 15 and press < SET > key to confirm.

4.3 Parameter Description

4.3.1 Individual Parameters (hopper)

Table 4-1: Individual Parameters (hopper) Description

Parameter Name	Function Description	Parameter Values	
		Default Value	Range
Hopper action	Hopper is on/off	Activate	
Preparation time	After the hopper starts, it will start to start normally after the preparation time.	3S	0-99S
Suction time	Suction valve action time	15S	0-999S
Shut-off time	Shut-off valve action time	3S	0-99S
Filter cleaing cycle	Purging valve action time Set it to 0: not cleaning after suction	0S	0-99S
Filter cleaing cycle	Enable filter cleaning after X cycle of material conveying. Set it to 1: cleaning the filter after each suction	0 times	0-99
Mixing time	Start at the same time with the suction action, and set the mixing time. Time calculation method: suction time * XX% Set it to 0: not start	0S	0-100%

Mixing proportion	Start at the same time with the suction action, and set the mixing proportion Time calculation method: suction time * XX% Set it to 0: not start	0S	0-100%
Mixing method	The number of layers of mixing action when mixing occurs. For example: suction time 20sec; mixing proportion 10%; layer: 2 layers; and the mixing action is: 9s—1s ----9s---1s Set single layer work, and the suction time range of 5-99 secs. Set double-layers work, and the suction time range of 17-99 secs. Set the three-layers work, and the suction time range of 32-99 secs. Set the four-layers work, and the suction time range of 46-99 secs. If the suction time is changed, the min. suction action of each layer is less than 1 sec. after calculation, and the program will force to change the action time to 1 sec.	1	1-4

4.3.2 Comm. Parameters (Overall Unit)

Table: 4-2: Comm. Parameters Description

Parameter Name	Function Description	Parameter Values	
		Default Value	Range
Alarm for several shortage times	Set the times that the materials not discharge from the hopper before it goes into alarm.	3S	0-99S
Vacuum breaking time	Vacumm breaking valve action time	2S	0-999S
Host unit screen cleaning cycle	Enable filter cleaning after X cycle of material conveying.	10 times	0-99 times
Wait before the host unit screen cleaning	The waiting time before filter cleaing, and after this time it starts to clean.	0S	0-99S
Wait after the host unit filter cleaning	The waiting time after filter cleaing, and after this time it starts next action.	0S	0-99S

Host unit filter cleaning time	Total filter cleaning time	0S	0-99S
Filter cleaning ON time	Filter cleaning intermittent action, and the time it starts before stop.	0S	0-99S
Filter cleaning OFF time	Filter cleaning intermittent action, and the time it stops before restart.	2S	0-99S
Motor delay time	After the suction time, other time that the motor takes before it stops.	0S	0-99S

4.3.3 Communication Parameter Setting

Press the <MENU> key and <UP> key at the same time for three seconds to enter the communication parameter setting screen.

Table 4-3: Parameter Description

Parameter Name	Function Description	Parameter Values	
		Default Value	Range
Communication Address	Communication address	1	1-99
Baud rate	4800 9600 19600	9600	
Parity bit	- odd parity even parity	-	
Stop bit	1 bit 2 bits	1	

4.4 Code Description

Table 4-4: Code Description

Panel Code	Function Description	Code	Function Description
M	suction motor running	C	shut-off
R	purging	P	standby
N	waiting time	OL	motor overload
D+时间	suction time	N+time	motor delay shutdown time
HP	high pressure	PV	mixing valve

4.5 Action Description

Action Description	Parameter Values	
	Default Value	Range
Filter screen cleaning before suction	15 secs.	0-99 secs.
Waiting time after screen cleaning	3 secs.	0-99 secs.
Material suction (vacuum breaking valve works)	30 secs.	0-999 secs.
Shut-off action	3 secs.	0-99 secs.
(The vacuum breaking valve closes after this action.)	2 secs.	0-999 secs.
Waiting time before cleaning	2 secs.	0-99 secs.
Filter cleaning after suction	15 secs.	0-99 secs.
Waiting time after screen cleaning	2 secs.	0-99 secs.
Wait for materials completely discharge into the hopper	10 secs.	5-99 secs.

4.6 Communication Parameter Table (Protocol modbus –RTU)

Table 4-6: Comm. Address (Protocol modbus-RTU) Parameters

Address (Keep the deposit area) (decimal system)	Parameter Content	Reading R/ Writing W	Default Parameters	Minimum	Maximum	Unit
1	Current action (machine current status)	R	/	/	/	/
	bit 0 shutdown			0	1	
	bit 1 standby			0	1	
	bit 2 suck the materials			0	1	
	bit 3 wait for material discharge			0	1	
	bit 4 clear the filter screen			0	1	
	bit 5 wait for material stop			0	1	
2	Real-time information	R	/	/	/	/
3	Output status 1	R	/	/	/	/
	bit 0 hopper 1 shut-off valve			0 no output	1 output	
	bit 1 hopper 2 shut-off valve			0 no output	1 output	
	bit 2 hopper 3 shut-off valve			0 no output	1 output	
	bit 3 hopper 4 shut-off valve			0 no output	1 output	
	bit 4 blower			0 no output	1 output	
	bit 5 purge			0 no output	1 output	
	bit 6 vacuum breaking			0 no output	1 output	
	bit 7 Alarm			0 no output	1 output	
	bit 8~ bit 16 undefined			/	/	
4	Output status 2	R	/	/	/	/
	bit 0 suck materials 1			0 no output	1 output	
	bit 1 suck materials 2			0 no output	1 output	
	bit 2 suck materials 3			0 no output	1 output	
	bit 3 suck materials 4			0 no output	1 output	
	Bit4~bit16 undefined			/	/	
5	Input status	R	/	/	/	/
	bit 0 hopper 1 shortage			0 no input	1 input	
	bit 1 hopper 2 shortage			0 no input	1 input	
	bit 2 hopper 3 shortage			0 no input	1 input	
	bit 3 hopper 4 shortage			0 no input	1 input	
	bit 4 Overload			0 no input	1 input	
	bit 5 High pressure			0 no input	1 input	

	Bit6~bit16 undefined			/	/	
6	Alarm status	R	/	/	/	
	bit 0 hopper1 shortage alarm			0 no alarm	1 alarm	
	bit 1 hopper 2 shortage alarm			0 no alarm	1 alarm	
	bit 2 hopper 3 shortage alarm			0 no alarm	1 alarm	
	bit 3 hopper 4 shortage alarm			0 no alarm	1 alarm	
	bit 4 overload alarm			0 no alarm	1 alarm	
	bit 5 High pressure alarm			0 no alarm	1 alarm	
	Bit6~bit16 undefined			/	/	
7	Hopper 1 switch	R/W	/	0 closed	1 start	/
8	Hopper 2 switch	R/W	/	0 closed	1 start	/
9	Hopper 3 switch	R/W	/	0 closed	1 start	/
10	Hopper 4 switch	R/W	/	0 closed	1 start	/
11	Hopper 1 preparation time	R/W	3	0	99	secs.
12	Hopper 2 preparation time	R/W	3	0	99	secs.
13	Hopper 3 preparation time	R/W	3	0	99	secs.
14	Hopper 4 preparation time	R/W	3	0	99	secs.
15	Hopper 1 suction time	R/W	30	0	999	secs.
16	Hopper 2 suction time	R/W	30	0	999	secs.
17	Hopper 3 suction time	R/W	30	0	999	secs.
18	Hopper 4 suction time	R/W	30	0	999	secs.
19	Hopper 1 shut-off time	R/W	3	0	99	secs.
20	Hopper 2 shut-off time	R/W	3	0	99	secs.
21	Hopper 3 shut-off time	R/W	3	0	99	secs.
22	Hopper 4 shut-off time	R/W	3	0	99	secs.
23	Shortage alarm times	R/W	3	1	99	times
25	Screen cleaing required times	R/W	10	1	99	times
26	Screen cleaing selection	R/W	0	0 before material suction	0 after material suction	
27	Waiting time before screen cleaning	R/W	2	0	99	secs.
28	Waiting time after screen cleaning	R/W	2	0	99	secs.
29	Screen cleaning time	R/W	15	0	99	secs.
30	Screen cleaning open time	R/W	2	0	99	secs.
31	Screen cleaning close time	R/W	2	0	99	secs.
32	Motor delay time	R/W	90	0	99	secs.
33	Delayed vacuum breaking time	R/W	2	0	999	secs.
34	Hopper 1 shortage time	R/W	3	1	9	secs.
35	Hopper 2 shortage time	R/W	3	1	9	secs.
36	Hopper 3 shortage time	R/W	3	1	9	secs.
37	Hopper 4 shortage time	R/W	3	1	9	secs.
38	Hopper 1 discharge check time	R/W	10	5	99	secs.

39	Hopper 2 discharge check time	R/W	10	5	99	secs.
40	Hopper 3 discharge check time	R/W	10	5	99	secs.
41	Hopper 4 discharge check time	R/W	10	5	99	secs.
43	Hopper 1 full-mat. time	R/W	1	1	9	secs.
44	Hopper 2 full-mat. time	R/W	1	1	9	secs.
45	Hopper 3 full-mat. time	R/M	1	1	99	secs.
46	Hopper 4 full-material time	R/W	1	1	9	secs.

Notes: R means only reading
W means only writing
R/W means reading/writing

Notes: There's no password set in factory before delivery, and it can be set by the customer. In case of loss, please contact us.

5. Troubleshooting

Fault	Possible reasons	Solutions
When shortage lasts long, and suction blower don't run.	The main switch and control switch don't open or the above two don't connect well.	Close the main switch and control switch and check their connecting.
	The microswitch on hopper don't connect well .	Adjust or replace.
	The signal wire is break off.	Re-connect.
The suction blower still running when the hopper is full.	The touch point is conglutinated	Repair or replace.
After several times of loading the material hopper still empty or the material shortage alarms.	The storage tank is empty.	Add the material
	The pipe is air leak.	Lock tightly and replace the vacuuming pipe.
	The filter is blocked.	Clean the filter.
The motor can't run.	Short-phase or motor was burnt out.	Check and replace.
The fuse always burnt out after start-up.	Short circuit or connect the ground.	Check the circuit.
Motor overload alarms	The filter is blocked.	Clean the filter and reset the overload relay.
	One of three phase is lacking.	Check the circuit and reset the overload relay.kkk
Poor material liquidityin the pipe	Over or lack of air quantity	Adjust air inlet location of the suction box. Avoid small bending of the elbow.

6. Maintenance

6.1 Hopper Cleaning(Take SVH as an example)

SMH Cleaning: In order to avoid air-blocking and to get smooth conveying.

Clean the filter screen inside of material hopper. Unlock the snap hook on the hopper, remove the hopper cover and take out the filter screen, then clean it. Clean the filter periodically or when the suction force is reduced.

SVH Cleaning:

1. Clean the filter screen, in order to avoid air-blocking and to get smooth conveying. Clean the filter screen inside of material hopper. Unlock the snap hook on the hopper, remove the cover and take out the filter, then clean it. Clean periodically or when the suction force is reduced.
2. Clean the glass pipe, when the dust accreted on the tube. Clean the dust in time for machine normal working.

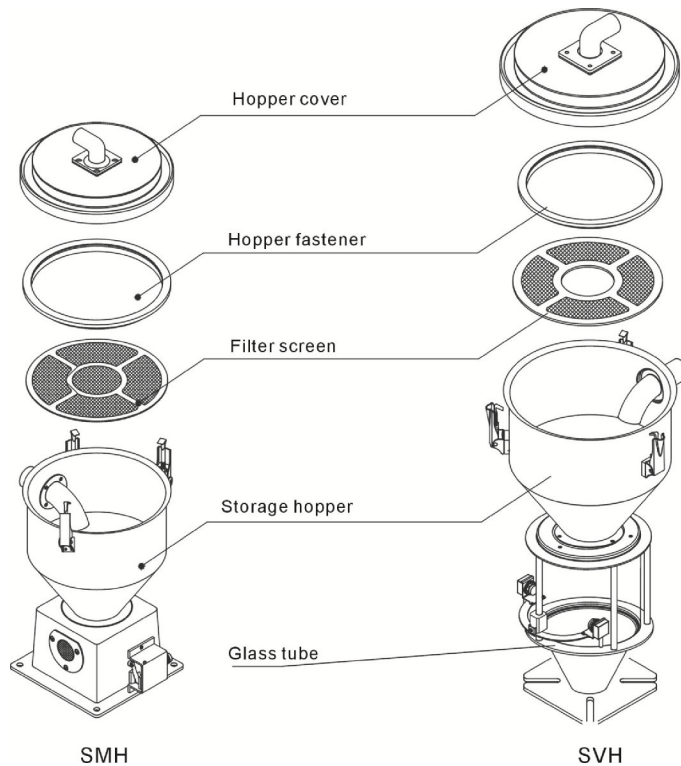

Picture 6-1: Hopper Cleaning

6.2 Main Body Cleaning

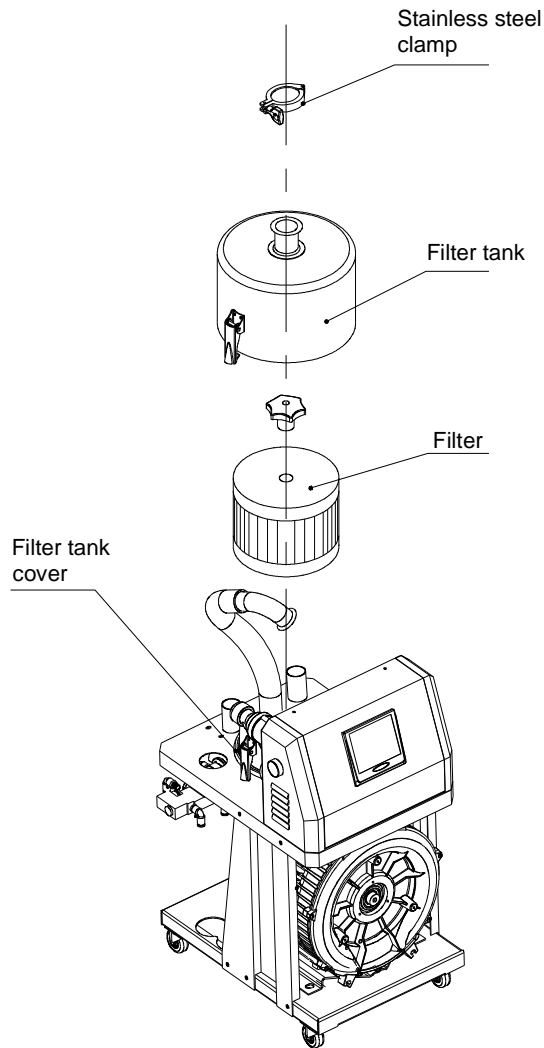

Picture 6-2: Filter Barrel Cleaning Diagram

1. Open the filter barrel cover and take out the filter; blow off the dust with a high pressure air gun from the inside to outside; take down the filter barrel lid and remove the dust in it.
2. Clean the filter. Period: daily