

# **SAL-G**

分离式真空填料机

"Standard" Separate-vacuum Hopper Loader

日期: 2013年11月

版本: Ver.B (中文版)

Date: Nov, 2013

Version: Ver.B (English)





## 目录 Content

<b>1. 各部件构造名称 Structure .....</b>	<b>6</b>
<b>2. 分解零件图 Parts .....</b>	<b>8</b>
2.1 SAL-700 .....	8
2.2 SAL-700 分解零件表 Spare Parts List.....	9
2.3 SAL-800G1/G2 .....	10
2.4 SAL-800G1/G2 分解零件表 Spare Parts List .....	11
2.5 SAL-900G1/G2 .....	13
2.6 SAL-900G1/G2 分解零件表 Spare Parts List .....	14
<b>3. 外形尺寸 External size .....</b>	<b>15</b>
<b>4. 规格表: Specification.....</b>	<b>18</b>
<b>5. 功能描述 Description Function .....</b>	<b>20</b>
5.1 工作原理 Working Principle.....	20
5.1.1 SAL-700G/800G 工作原理 Working Principle.....	20
5.1.2 SAL-700G/800G 工作原理 Working Principle.....	21
5.1.3 SAL-900G 工作原理 Working Principle .....	23
<b>6. 安全规则 Safety Regulations .....</b>	<b>25</b>

<b>7. 安装示意图</b> Installing Layout.....	<b>27</b>
<b>8. 操作说明</b> Operation.....	<b>34</b>
8.1 SAL-700G/800G 操作说明 Operation .....	34
8.2 功能设定 Function Setup .....	36
8.2.1 设定方法 Setup .....	36
8.2.2 动作说明 Actions .....	38
8.2.3 参数说明 Parameter List .....	45
8.2.4 其它设定 Other settings .....	47
8.3 SAL-900G 操作说明 Operation .....	48
<b>9. 清洁保养</b> Maintenance .....	<b>51</b>
9.1 料斗的清洁 Hopper cleaning.....	51
9.2 主体的清洁 Main body cleaning .....	51
<b>10. 故障排除</b> Troubleshooting.....	<b>55</b>
<b>11. 电路图</b> Electric diagram .....	<b>56</b>
11.1 SAL-700G 电路图 Electric diagram(1 $\Phi$ 200~230V 50/60Hz).....	56
11.2 SAL-700G 组件布置及端子接线图 Layout and Component Video Wiring Diagram (1 $\Phi$ 200~230V 50/60Hz) .....	57

11.3 SAL-700G 电气组件明细 Bill of Electrical Parts .....	58
11.4 SAL-800G 电路图 Electric diagram (3Φ 400V 50/60Hz).....	59
11.5 SAL-800G 组件布置及端子接线图 Layout and Component Video Wiring Diagram (3Φ 400V 50/60Hz) .....	60
11.6 SAL-800G 电气组件明细 Bill of Electrical Parts .....	61
11.7 SAL-800G2 电气组件明细 Bill of Electrical Parts .....	62
11.8 SAL-900G 电路图 Electric diagram (3Φ 400V 50/60Hz).....	63
11.9 SAL-900G 组件布置及端子接线图 Layout and Component Video Wiring Diagram (3Φ 400V 50/60Hz) .....	64
11.10 SAL-900G 电气组件明细 Bill of Electrical Parts.....	65
11.11 SAL-900G2 电气组件明细 Bill of Electrical Parts.....	66

# 1. 各部件构造名称 Structure

SMH



- (A) 吸气口 Air inlet
- (B) 上盖 Filter housing
- (C) 弹簧扣 Spring buckle
- (D) 吸料口 Material inlet
- (E) 储料桶 Material hopper
- (F) 微动开关 Microswitch

(G) 底座 Base

SVH

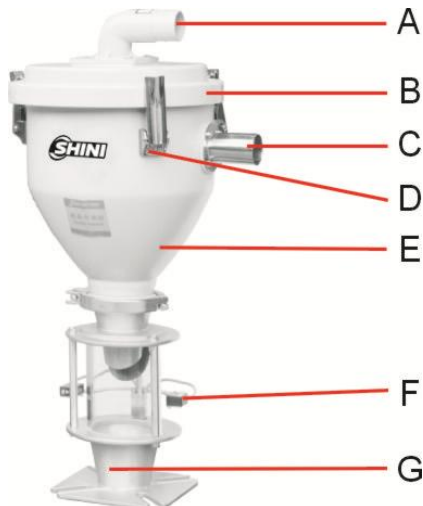

- (A) 吸气口 Air inlet
- (B) 上盖 Filter housing
- (C) 吸料口 Material inlet
- (D) 弹簧扣 Spring buckle
- (E) 储料桶 Material hopper
- (F) 电眼 Photosensor

(G) 底座 Base



SAL-700G/GE



SAL-800G/GE



SAL-900G/GE

(H) 吸气口 Air inlet

(I) 滤清器护罩 Filter housing

(J) 配电箱 Controller-box

(K) 主体 Main body

## 2. 分解零件图 Parts

### 2.1 SAL-700

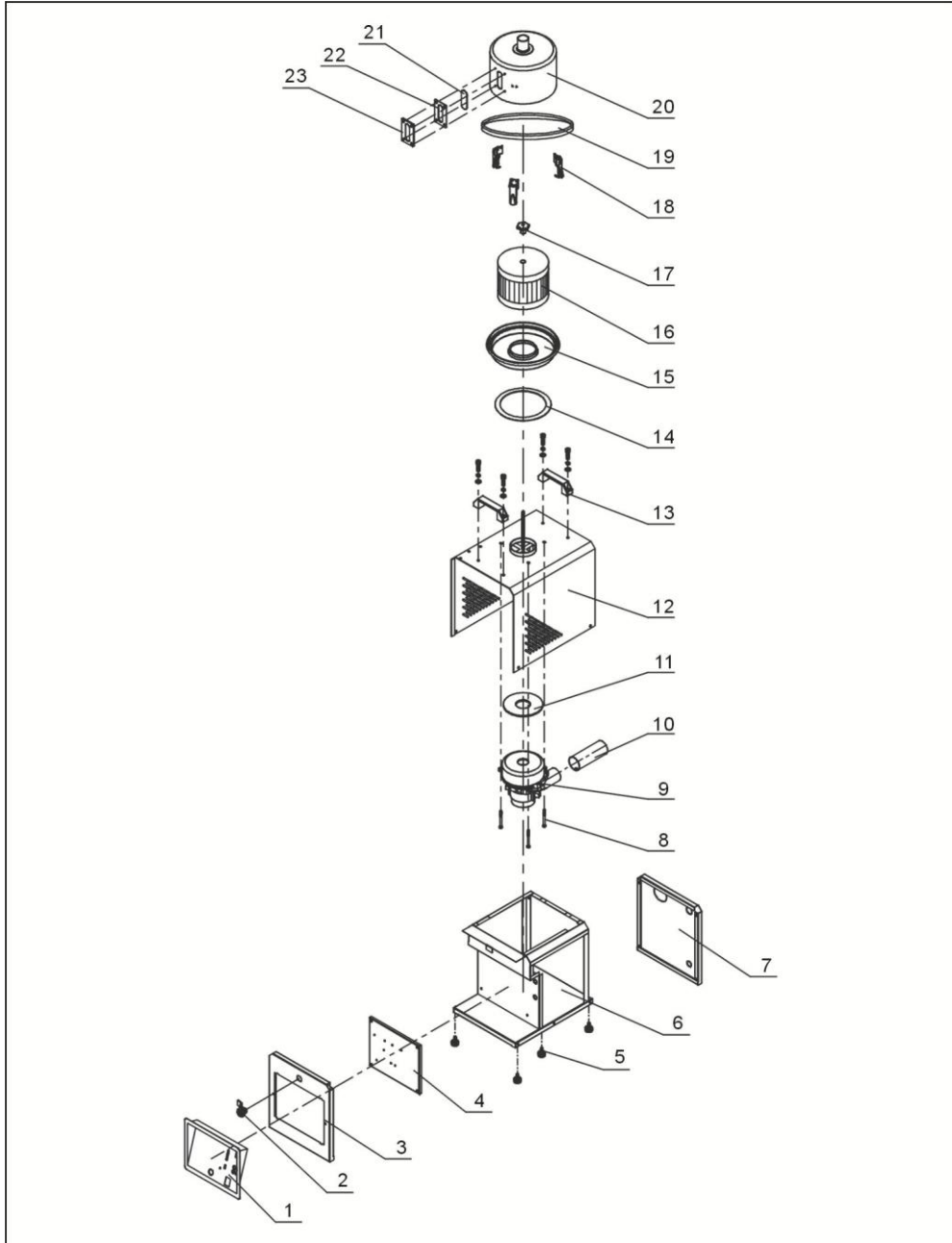

## 2.2 SAL-700 分解零件表 Spare Parts List

序号 Nos.	名称	Component Name	物料编号 Parts number
1	面板	Panel	YR40070000000
2	门锁	Door lock	YW00000600000
3	门板	Door plate	-
4	电气固定板	Electrical components fix plate	-
5	脚垫	Foor cushion	YR40301740000
6	外架组件	Frame components	-
7	后板	Back plate	-
8	内六角圆头螺钉	Inner hexagon column screw	YW61066500100
9	碳刷马达	Carbon brush motor	-
10	排风管	Air outlet pipe	-
11	马达迫紧	Motor fastener	YP62141200000
12	外罩	Outside cover	-
13	铝方型拉手	Square aluminum handle	BW20012000040
14	自粘海绵迫紧	Sponge Fastener	YP62141200000
15	过滤桶盖	Filter cover	-
16	过滤器	Filter	YR50708000100
17	梅花螺母	Octagon nut	YW09051600000
18	弹簧扣	Spring buckle	YW02003000400
19	过滤桶迫紧	Filter seal	YR10708000100
20	过滤桶	Filter barrel	-
21	四孔压克力	Four-hole acrylic	YR40001200100
22	四孔视料窗迫紧	Four-hole visual window seal	YR40000400000
23	四孔视料窗铁片	Four-hole visual window chip	BH90000400050

\*表示可能损坏的项目；\*\*表示较可能损坏的项目，建议备份。

请在下单采购零配件之前，先确认说明书版本号，以确保零配件物料号与实物一致。

\* means possible broken parts.

\*\* means easy broken part. and spare backup is suggested.

Please confirm the version of manual before placing the purchase order to guarantee that the item number of the spare part is in accordance with the real object.

## 2.3 SAL-800G1/G2

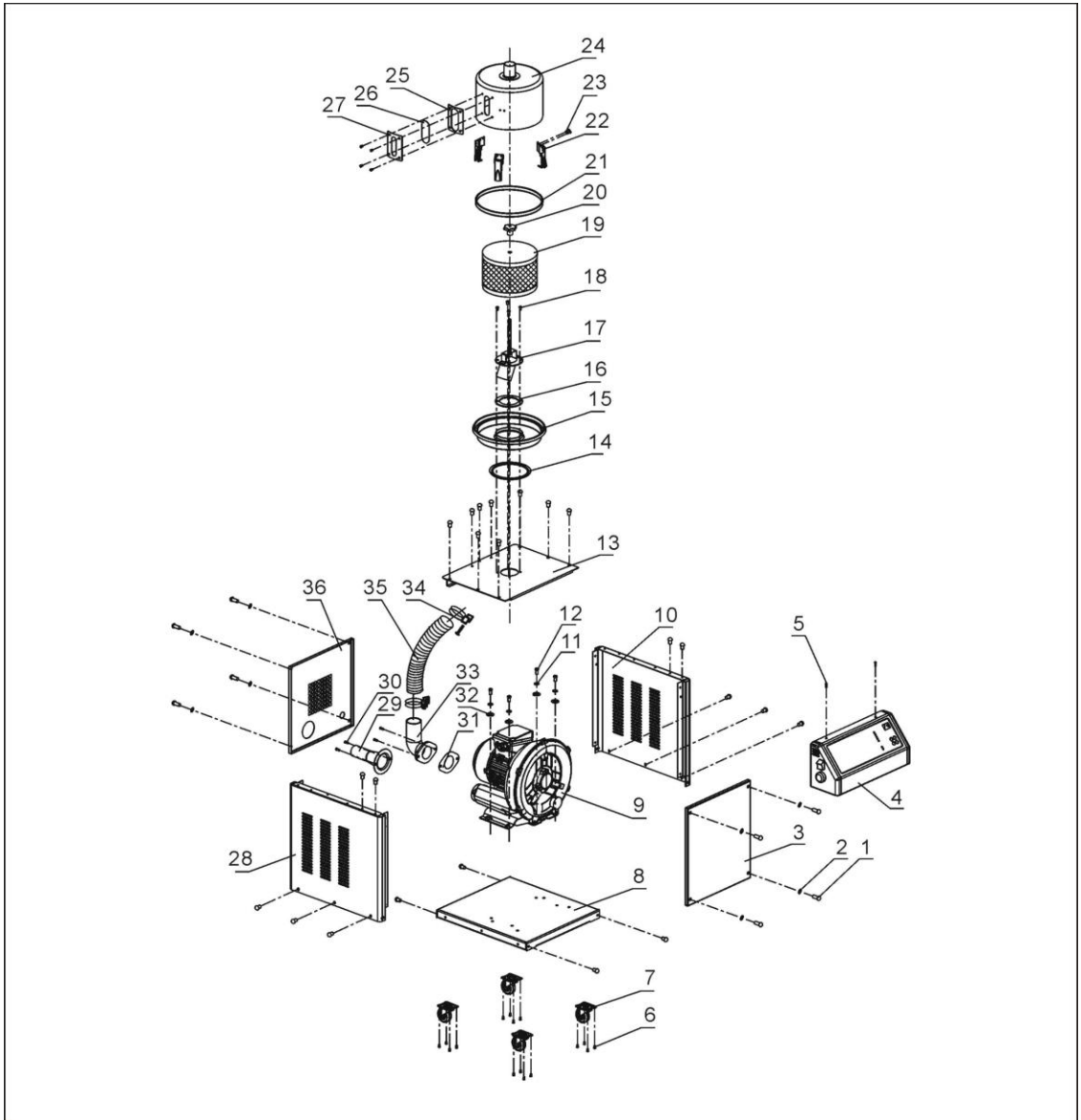

## 2.4 SAL-800G1/G2 分解零件表 Spare Parts List

序号 Nos.	名称	Component Name	物料编号 Parts number
1	十字槽盘头螺钉 M6×20	Cross socket head cap screw M6×20	YW63062000000
2	平垫圈 6	Flat gasket 6	YW66061200000
3	前板	Front plate	BL20080000920
4	控制箱	Control box	-
5	十字槽盘头螺钉 M4×5	Cross recessed pan head screw M4×5	YW62040500000
6	十字槽盘头螺钉 M5×10	Cross recessed pan head screw M5×10	YW62051000100
7	万向轮 2"	Universal wheel 2"	YW03000200000
8	底板	bottom plate	BL20080000020
9	信易风机 RP-310/1HP	Shini blower RP-310/1HP	BM30031000150
10	右侧板	Right side plate	-
11	弹簧垫圈 8	Spring washer 8	YW65008000000
12	六角头螺栓 M8×16	Hexgon head screw M8×16	YW60081600100
13	上面板	Top plate	BL32080000000
14	迫紧	Fastener	-
15	过滤桶盖	Filter cover	-
16	入料管迫紧	Material inlet fastener	-
17	过滤桶底座	Filter base	-
18	十字槽盘头螺钉 M6×10	Cross recessed pan head screw M6×10	YW62061000000
19	过滤器	Filter	YR50708000100
20	梅花螺母 5/16"	Star nut 5/16"	YW09051600000
21	过滤桶迫紧	Filter Fastener	YR10708000100
22	弹簧扣	Snap hook	YW02003000400
23	拉钉 5-1	Rivet 5-1	YW69050100000
24	过滤桶	Filter barrel	-
25	四孔视料窗迫紧	Four-hole fastener for sight glass window	YR40000400000
26	四孔压克力	Four hole acryl	YR40001200100
27	四孔视料窗	Four-hole sight glass window	YW09000000400
28	左侧板	Left side plate	-
29	排风口	Air outlet	YR40080000100
30	十字槽盘头螺钉 M6×15	Cross recessed pan head screw M6×15	YW63061500000
31	马达吸风口迫紧 1HP	Motor air inlet fastener 1HP	YR10001000000
32	平垫圈 8	Flat gasket 8	YW66082200000
33	弯头	Elbow	YR40004700000

序号 Nos.	名称	Component Name	物料编号 Parts number
34	管束 2"	Pipe clamp 2"	YW02005700000
35	钢丝螺纹管 2 寸	Steel-wire thread pipe 2"	YW90215000000
36	后板	Rear plate	-

\*表示可能损坏的项目；\*\*表示较可能损坏的项目，建议备份。

请在下单采购零配件之前，先确认说明书版本号，以确保零配件物料号与实物一致。

\* means possible broken parts.

\*\* means easy broken part. and spare backup is suggested.

Please confirm the version of manual before placing the purchase order to guarantee that the item number of the spare part is in accordance with the real object.

## 2.5 SAL-900G1/G2

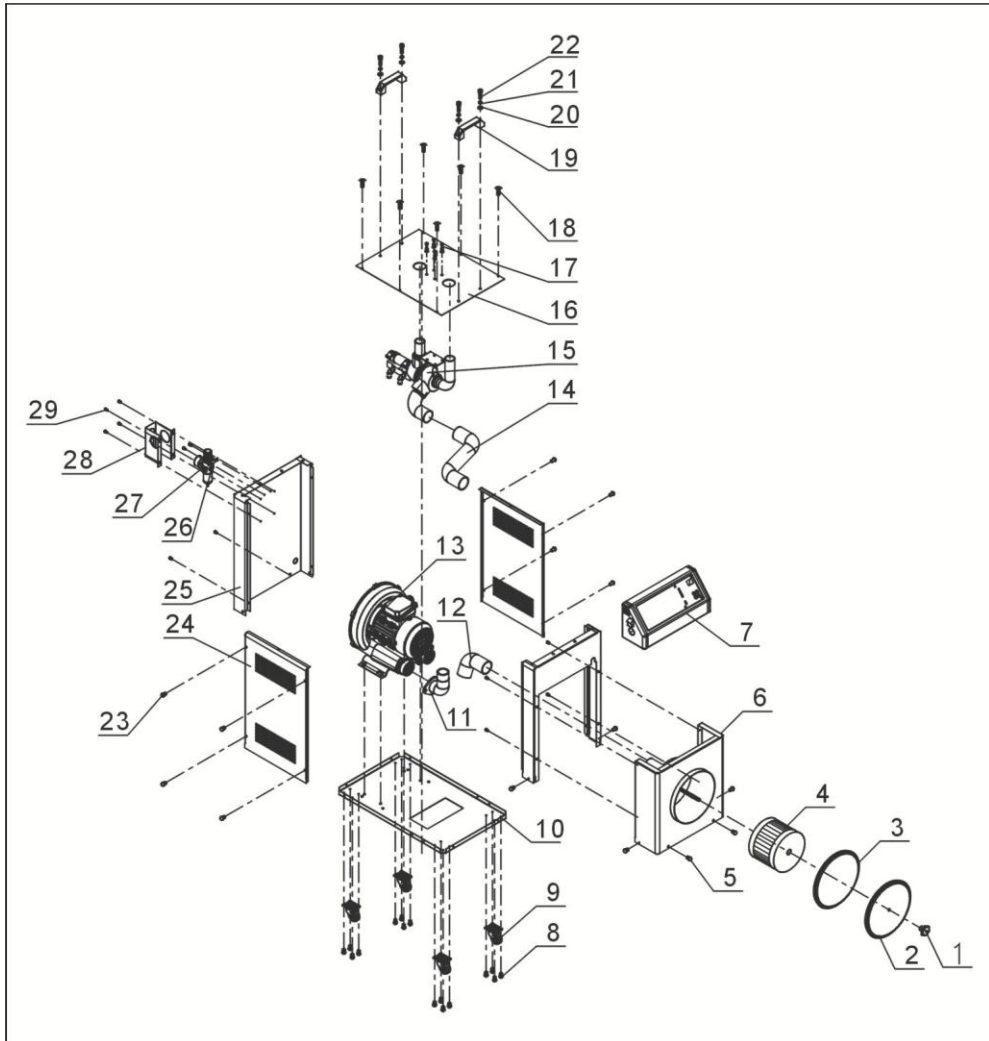

## 2.6 SAL-900G1/G2 分解零件表 Spare Parts List

序号 Nos.	名称	Component Name	物料编号 Parts number
1	控制箱	Octagon nut	YW09051600000
2	过滤桶盖	Filter cover	-
3	过滤桶盖迫紧	Filter cover seal	-
4	过滤器	Filter	-
5	十字槽盘头螺钉	Cruciform slot screw	YW64000300000
6	前板	Front board	-
7	控制箱	Control box	-
8	十字槽盘头螺钉	Cruciform slot screw	YW62051000100
9	脚轮	Truckle	YW03000200000
10	底座	Base	-
11	马达吸风管	Motor suction tube	-
12	钢丝螺纹管 1	Steel wire threaded tubes 1	YW90215000000
13	高压风机 1HP	High pressure bolwer 1HP	BM30031000150
	高压风机 2HP	High pressure bolwer 2HP	BM30042000050
14	钢丝螺纹管 2	Steel wire threaded tubes 2	YW90215000000
15	三通管	Three-way tube	-
16	盖板	Cover	-
17	六角头螺栓	Hexagon screw bolt	YW60061200100
18	十字槽盘头螺钉	Cruciform slot screw	YW64000300000
19	拉手	Handle	BW20012000040
20	平垫圈	Flat washer	YW66061300000
21	弹簧垫圈	Spring washer	YW65006000000
22	内六角圆柱头螺栓	The hexagonal bolts	YW61062000300
23	十字槽盘头螺钉	Cruciform slot screw	YW61062000300
24	侧板	Flank board	-
25	后板	Rear board	-
26	过滤调压阀	Filter & pressure regulating valve	YE30004200000
27	安装支架	Mounting bracket	YE30421400000
28	过滤调压阀外罩	Filter & pressure regulating valve cover	-
29	十字槽盘头螺钉	Cruciform slot screw	YW62051000100

\*表示可能损坏的项目；\*\*表示较可能损坏的项目，建议备份。

请在下单采购零配件之前，先确认说明书版本号，以确保零配件物料号与实物一致。

\* means possible broken parts.

\*\* means easy broken part. and spare backup is suggested.

Please confirm the version of manual before placing the purchase order to guarantee that the item number of the spare part is in accordance with the real object.

### 3. 外形尺寸 External size

SMH-6L/12L

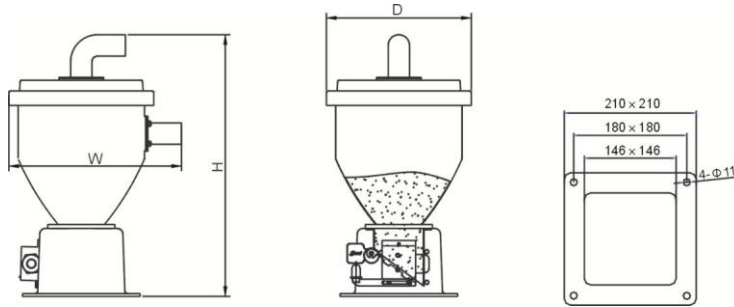

SVH-3L/6L/12L

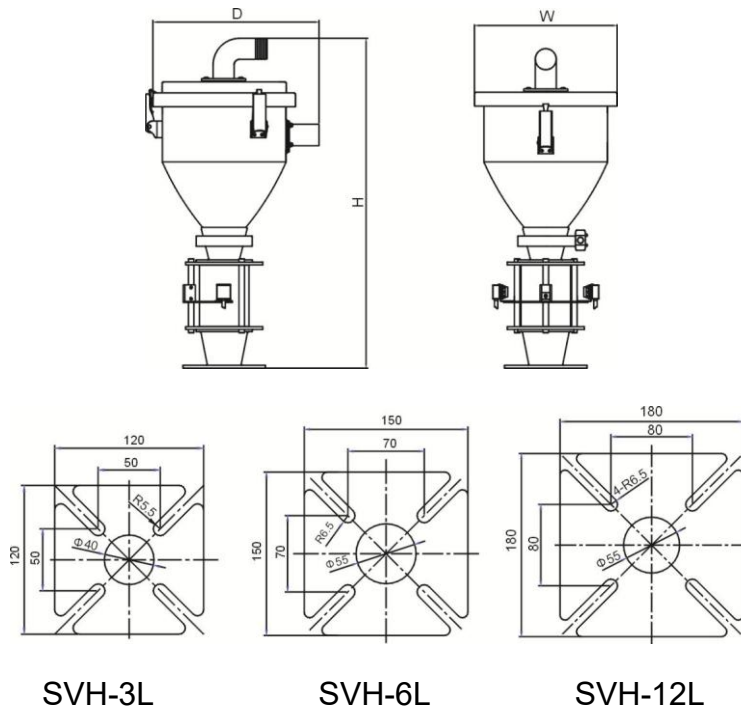

SAL-700G (主机 Main Controller)

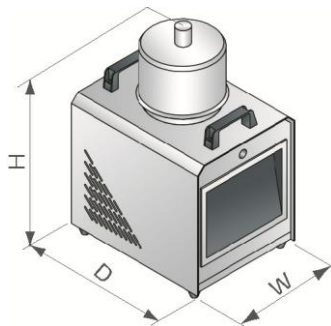

SAL-800G/800G2 (主机 Main Controller)

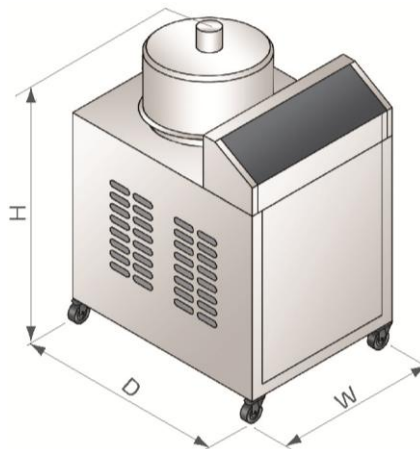

SAL-900G/900G2(主体 Main controller)

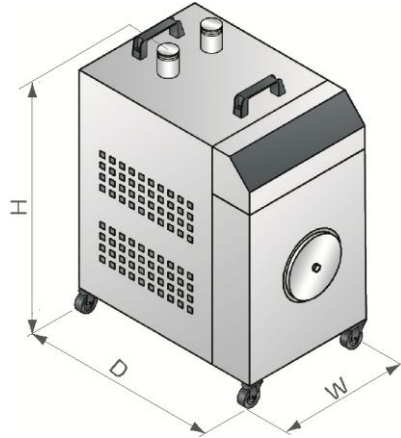

## 4. 规格表: Specification

SAL-700G/800G/800G2/900G/900G2 规格表

主机					料斗				输料管管径 (inch)	吸风管径 (inch)	输送能力 (kg/hr)
机型	马达型式	马达功率 (KW)	外形尺寸 (mm) H×W×D	重量 (kg)	可选型号	储料斗容量 (L)	外形尺寸(mm) H×W×D	重量 (kg)			
SAL-700G	碳刷式	1.2 (1Φ)	590×300×390	18	SMH-6L	6	460×260×315	4.5	1.5	2	400
					SVH-6L		600×260×305				
SAL-800G	感应式	0.75 (3Φ)	665×370×405	40	SMH-6L	6	460×260×315	7.5	1.5	2	550
					SVH-6L		600×260×305				
SAL-800G2	感应式	1.5 (3Φ)	665×370×405	47	SMH-12L	12	515×300×350	9	1.5	2	850
					SVH-12L		695×300×360				
SAL-900G	感应式	0.75 (3Φ)	670×390×740	50	1×SMH-6L	6	460×260×315	9	1.5	2	1200
					1×SVH-6L		600×260×305				
					2×SMH-6L		460×260×315				
					2×SVH-6L		600×260×305				
SAL-900G2	感应式	1.5 (3Φ)	670×390×740	47	1×SMH-12L	12	515×300×350	9	1.5	2	1350
					1×SVH-12L		695×300×360				
					2×SMH-12L		515×300×350				
					2×SVH-12L		695×300×360				

- 注: 1) “2” 表示采用 2HP 风机; 产品规格若有变更, 恕不另行通知。
- 2) “G”表示主机采用分离式;
- 3) “SMH”表示真空料斗, “SVH”表示电眼料斗;
- 4) 吸料斗内部做抛光处理, 机型后加注“P”;
- 5) 可选购 ACF-1 旋风集尘器 (额外安装于主机后方);
- 6) 输送能力测试条件为: 堆积密度约 0.65kg/L, 直径为 3~5 mm 塑料原料颗粒, 以垂直高度 4m, 水平距离 5m 为测试标准所得;
- 7) 机器电压规格除 SAL-700G 为: 1Φ, 230VAC, 50Hz, 其余機種皆为: 3Φ, 400VAC, 50Hz。

## SAL-700G/800G/800G2/900G/900G2 Series

Main Unit					Hopper Receiver(s)				Conveying Hose Dia. (Inch)	Air Suction Pipe Dia. (Inch)	Conveying Capacity (kg / hr)
Model	Motor Type	Motor Power (kW)(50 / 60Hz)	Dimensions (mm) H×W×D	Weight (kg)	Recommended Model	Hopper Capacity (L)	Dimensions (mm) H×W×D	Weight (kg)			
SAL-700G	Carbon brush	1.2/1.45 (1Φ)	590×300×390	18	SMH-6L	6	460×260×315	4.5	1.5	2	400
					SVH-6L		600×260×305				
SAL-800G	Induction	0.75/0.85 (3Φ)	665×370×405	40	SMH-6L	6	460×260×315	7.5	1.5	2	550
					SVH-6L		600×260×305				
SAL-800G2	Induction	1.5/1.8 (3Φ)	665×370×405	47	SMH-12L	12	515×300×350	9	1.5	2	850
					SVH-12L		695×300×360				
SAL-900G	Induction	0.75/0.85 (3Φ)	670×390×740	50	1×SMH-6L	6	460×260×315	9	1.5	2	1200
					1×SVH-6L		600×260×305				
					2×SMH-6L		460×260×315				
					2×SVH-6L		600×260×305				
SAL-900G2	Induction	1.5/1.8 (3Φ)	670×390×740	47	1×SMH-12L	12	515×300×350	9	1.5	2	1350
					1×SVH-12L		695×300×360				
					2×SMH-12L		515×300×350				
					2×SVH-12L		695×300×360				

Notes: 1) "2" stands for 2HP blower.

2) "G" stands for separate design of hopper receiver (s) and main unit (s).

3) "SVH" stands for photosensor hopper receiver; " SMH " stands for vacuum hopper receiver.

4) For polished hopper inside ones, add "P" at the end of model code.

5) It is available to select ACF-1 cyclone dust separator (Additonally mount at the back of main unit).

6) Test condition of conveying capacity: Plastic material of bulk density 0.65kg/L, dia. 3~5 mm, vertical conveying height: 4m, horizontal conveying distance: 5m.

7) Power supply: 3Φ, 230/400/460/575V, 50/60Hz for all models except SAL-700G (1Φ, 115/230V, 50/60Hz).

## 5. 功能描述 Description Function

### 5.1 工作原理 Working Principle

SAL-G 分离式自动填料机系列，适用于塑料颗粒的输送，主要利用马达运转产生真空，使料桶内产生压力差来输送塑料。

SAL-G series "Econo" Separate-vacuum hopper loader are suitable for conveying plastic granules over long distance. Utilizing high efficiency vacuum blower to produce vacuum in material hopper, plastic materials will then be fed into material hopper by outside pressure.

#### 5.1.1 SAL-700G/800G 工作原理 Working Principle

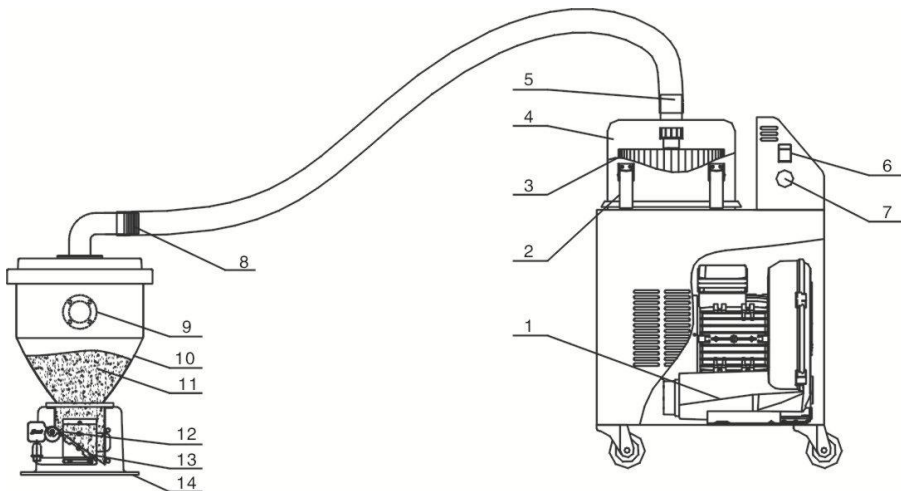

- |                              |                            |               |
|------------------------------|----------------------------|---------------|
| 1. 风机 Blower                 | 2. 弹簧扣 Spring clip         | 3. 过滤器 Filter |
| 4. 过滤器护罩 Filter house        | 5. 吸风管 Suction tube        |               |
| 6. 切替开关 Switch               | 7. 蜂鸣器 Buzzer              |               |
| 8. 料斗吸风管 Hopper suction tube | 9. 入料管 Material inlet pipe |               |

10. 料斗 Hopper                      11. 原料 Material                      12. 微动开关 Micro-I switch
13. 挡料板 Material deflector plate                      14. 四方底座 Base

开机后，风机（1）工作，使料斗（10）内产生真空，挡料板（12）关闭，储料桶中的原料由于空气压力差从入料管（9）进入料斗（10）内，当吸料动作完成后，风机停止运转，料会因自重下落，当微动开关（13）侦测到无料时，马达将再次启动，当三次吸不上料或缺料时，控制箱上的警报灯（7）会报警。

After start, blower (1) began to work, vacuum inside of material hopper (10), meanwhile non-return flap (12) is closed. Materials will be drawn into material hopper (10) by pressure difference through material inlet (9). When material suction is completed, materials automatically fall down by self-gravity. Motor will start to work again when reed switch (13) detects no materials left in the hopper. If the machine cannot draw materials for three times, the red alarm lamp (7) on control box will blink.

### 5.1.2 SAL-700G/800G 工作原理 Working Principle

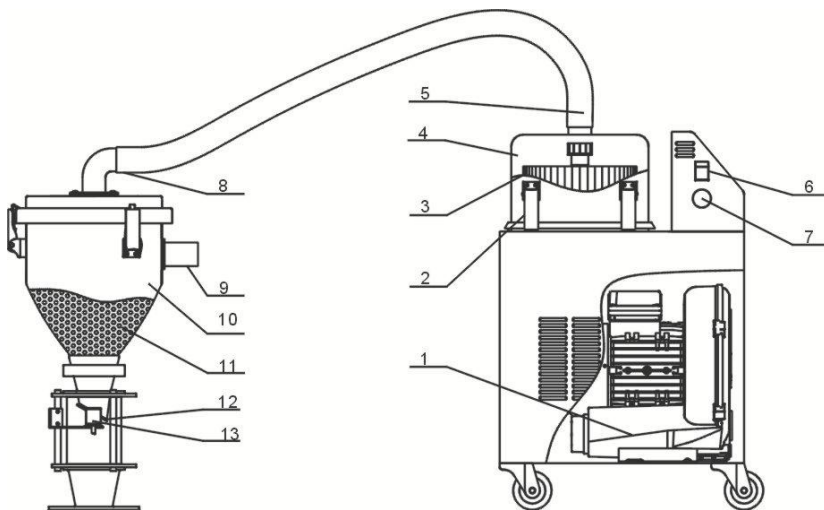

1. 风机 Blower                      2. 弹簧扣 Spring clip                      3. 过滤器 Filter

4. 过滤器护罩 Filter house    5. 吸风管 Suction tube    6. 切替开关 Switch
7. 蜂鸣器 Buzzer                      8. 料斗吸风管 Hopper suction tube
9. 入料管 Material inlet pipe    10. 料斗 Hopper                      11. 原料 Material
12. 逆止片 Reverse stopping flap                      13. 电眼 Sensor

开机后，风机（1）工作，使料斗（11）内产生真空，逆止片（12）关闭，储料桶中的原料由于空气压力差从入料管（9）进入料斗（10）内，当吸料动作完成后，风机停止运转，料会因自重下落，当微动开关（13）侦测到无料时，马达将再次启动，当三次吸不上料或缺料时，控制箱上的警报灯（7）会报警。

After start, blower (1) began to work, vacuum inside of material hopper (11), meanwhile non-return flap (12) is closed. Materials will be drawn into material hopper (10) by pressure difference through material inlet (9). When material suction is completed, materials automatically fall down by self-gravity. Motor will start to work again when reed switch (13) detects no materials left in the hopper. If the machine cannot draw materials for three times, the red alarm lamp (7) on control box will blink.

### 5.1.3 SAL-900G 工作原理 Working Principle

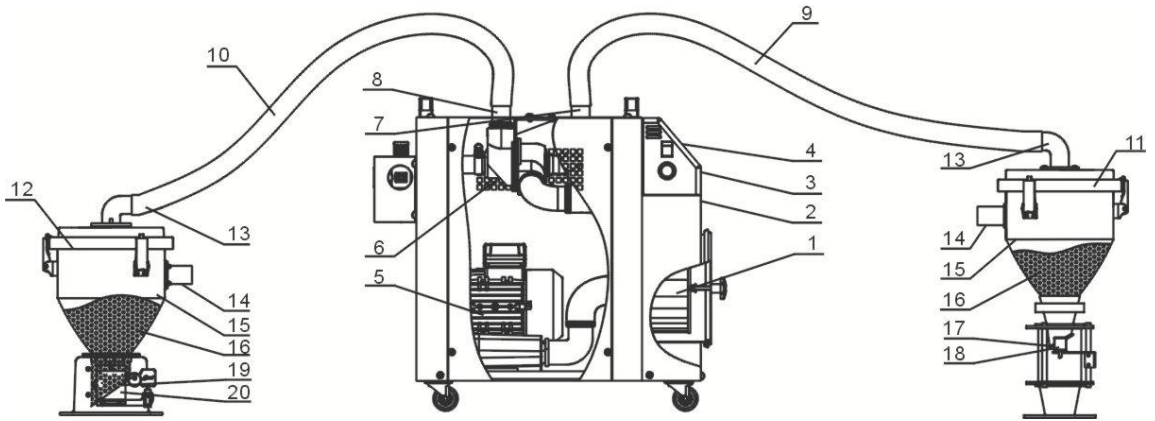

- |   |                                  |                |
|---|----------------------------------|----------------|
| 1. 过滤器 Filter                                   | 2. 蜂鸣器 Buzzer                    | 3. 切替开关 Switch |
| 4. 操作面板 Operation panel                         | 5. 风机 Blower                     |                |
| 6. 三通阀 Three way valve                          | 7. 吸风口 1 Air suction hols 1      |                |
| 8. 吸风口 2 Air suction hols 2                     | 9. 吸风管 1 Suction tube 1          |                |
| 10. 吸风管 2 Suction tube 2                        | 11. 料斗 1 Hopper 1                |                |
| 12. 料斗 2 Hopper 2                               | 13. 料斗吸风管 Hopper suction tube    |                |
| 14. 入料管 Material inlet pipe                     | 15. 储料斗 Storage bin              |                |
| 16. 原料 Material                                 | 17. 逆止片 Reverse stopping flap    |                |
| 18. 对射式光电开关 Opposite-tgpe photoelectrial sensor |                                  |                |
| 19. 微动开关 Micro-l switch                         | 20. 挡料板 Material defleltor plate |                |

打开切替开关 (3) , 通过操作面板 (4) 设定料斗 1 (11) 与料斗 2 (12) 的吸

料时间，按下启动按钮，风机（5）工作，三通阀控制吸风口 1（7）打开，吸风口 2（8）关闭，逆止片（17）关闭，料斗 1（11）开始吸料，吸料完成后，风机停止运转，料斗 1（11）中原料因自重而下落，当微动开关（20）检测到料斗 2（12）无料时，风机（1）工作，此时电磁阀切换，三通阀控制吸风口 2（8）打开，挡料板（19）关闭，料斗 2（12）吸料，吸料完成后，如果对射式光电开关（18）检测到料斗 1（11）无料时，通过电磁阀切换，马达又会启动开始吸料，如此循环吸料，当吸不上料或缺料时，控制箱上的蜂鸣器（2）会报警。

Turn on the alternative switch (3), via the operation panel (4), set the suction time of the loader 1 (11) and loader2 (12), then press the start button and the blower (5) starts work. The three way valve1 (7) opens and the air suction inlet 2 (8) closes, non-return flap (17) closes, and then hopper 1 (11) starts to suctioning material, after material suction finishes, the blower stops. Because of deadweight, material drops down. When the micro switch (20) detect that there is no material in the loader2 (12), blower (1) works again. And solenoid valve works, three way valve2 (8) controlled air suction inlet opens, and flap plate (19) closes, loader2 (12) begins to suctioning material, when finished, if photoelectric switch (19) detect that there is no material in loader1 (11), via the solenoid valve alternative, the motor start working again. The machine works according to this cycle. The buzzer will give an alarm when material can not be sucked or there is no material.

## 6. 安全规则 Safety Regulations

为避免造成人身伤害及机器损坏，请依照本说明书上的安全规则。

在操作本机时，必须要遵守以下的安全规则。

Please abide by the safety guide when you operate the machine so as to prevent damage of the machine and personal injuries.



电器安装应由专业的电工来完成。

在机器维修保养时必须关闭主开关及控制开关。

All electrical components should be installed by qualified electricians.  
Turn off main switch and control switch during repair and maintenance.



警告！高压危险！

此标签贴在电控箱外壳上！

Warning! High voltage!

This mark is attached on the cover of the control box.



警告！小心！

此标签表示在该处应多加小心！

Warning! Be careful!

Be more careful when this mark appears.



注意！

电控箱内所有安装电气组件的螺丝全部锁紧，无需定期检查！

Attention!

No need for regular inspection because all the electrical parts in the control unit are fixed tightly!

## 7. 安装示意图 Installing Layout

SAL-700G/800G Series

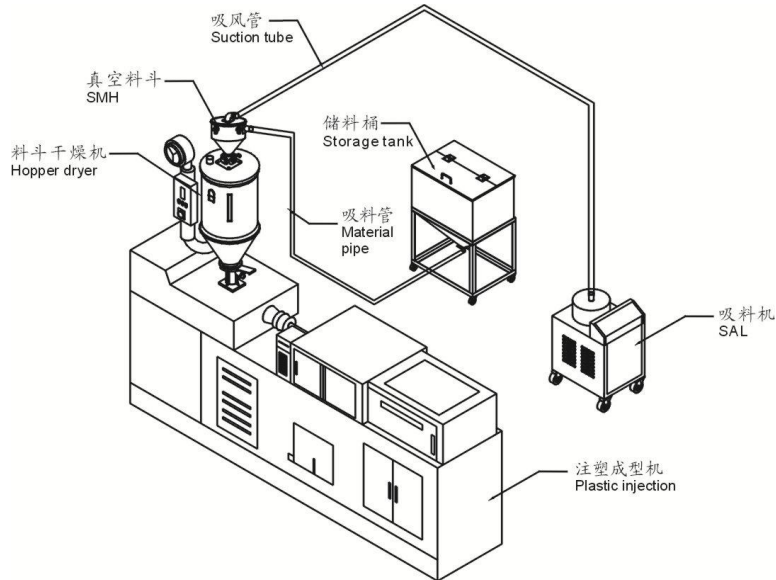

安装步骤:

- 1、将 SAL-700G/800G 放置于合适的地方，并连接好电源线。
- 2、将附带真空料斗安装于料斗干燥机上，并将信号线接到 SAL-700G/800G 吸料机上。
- 3、用钢丝软管分别将真空料斗吸气口连接到对应的 SAL-700G/800G 吸气口上，将储料仓吸料口连接到真空料斗吸料口处。

INSTALLATION:

1. Place the machine SAL-700G/800G at a proper position on the ground, Connect the three phase power cord and the earth.
2. Install the material hopper on the top of hopper dryer, and connect the signal to the machine SAL-700G/800G.

3. Use the steel wire soft hose, connect the air inlets of SMH to SAL-700G/800G.  
Then connect the other port on SMH to the material hose of storage tank.

## SAL-900G Series

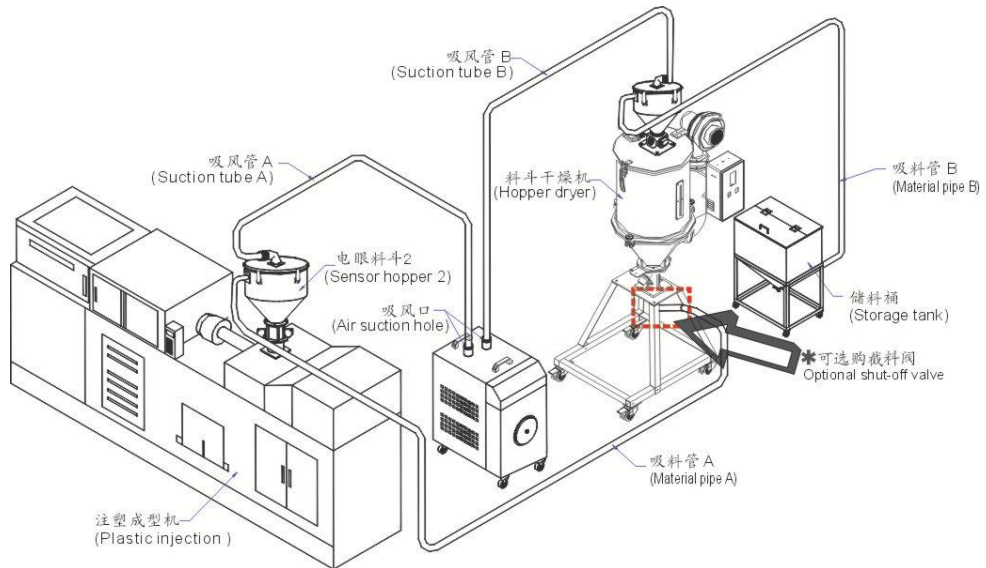

### 安装步骤:

- 1、将 SAL-900G 放置于合适的地方，并连接好电源线。
- 2、将附带真空料斗安装于料斗干燥机上，电眼料斗 2 安装于注塑机上，并将信号线接到 SAL-900G 吸料机上。
- 3、用钢丝软管分别将电眼料斗 2 吸气口与真空料斗吸气口连接到对应的 SAL-900G 吸气口上，将储料仓吸料口连接到真空料斗吸料口，将料斗干燥机吸料口连接到电眼料斗 2 吸料口。

### INSTALLATION:

1. Place the SAL-900G machine at a proper position on the ground, Connect the three phase power cord and the earth.
2. Install the material hopper on the top of the hopper dryer and the sensor Hopper 2 onto the plastic injection machine. Connect the signal cord to the machine SAL-900G .

3. Use the steel wire soft hose, connect the air inlet of the material hopper and the sensor hopper 2 to the current air inlets of the SAL-900G with air suction hose. Then connect the material inlets of storage tank to the material hopper. And connect the material inlets of the sensor hopper to the hopper dryer.

\*可选购加装截料阀装置，它能实现吸料管管中无料残留，可避免原料残留管中回潮，其工作原理是：

截料阀与电眼料斗 2 是连动的，当料斗 2 吸料时，截料阀立刻打开一段时间(可调)后关闭，吸料机继续吸料，将吸料管 A 的料完全吸入料斗 2。

Optional Shut-off valve. It makes no material to remain in the suction material hose, and avoid to remaining material be moisture regain. Its working principle: The shut-off valve is linked-do with the sensor hopper 2, when the hopper 2 is working, the shut-off valve can be open, and it lasted for some time (adjusted time), then it can be close. In this period, the Auto-load goes on working for suction, and the material remain in the material hose A will be sucked to sensor hopper 2 completely.

SAL-900GE Series

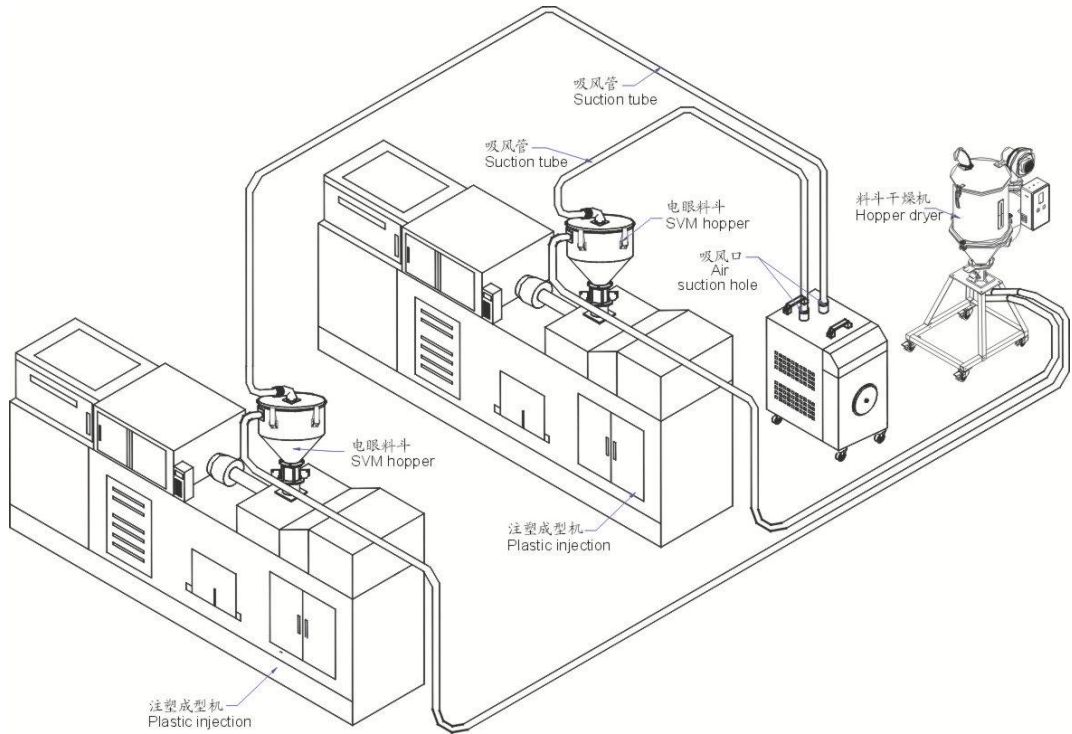

### 安装步骤:

- 1、将 SAL-900GE 放置于合适的地方，并连接好电源线。
- 2、将电眼料斗安装于注塑机上，并将信号线接到 SAL-900GE 吸料机上。
- 3、用钢丝软管分别将电眼料斗吸气口连接到对应的 SAL-900GE 吸气口上，将储料仓吸料口连接到电眼料斗吸料口，将料斗干燥机吸料口连接到电眼料斗吸料口。

### INSTALLATION:

1. Place the SAL-900GE machine at a proper position on the ground, Connect the three phase power cord and the earth.
2. Install the sensor hopper(SVH) on the plastic injection machine. Connect the signal cord to the machine SAL-900GE .

- Use the steel wire soft hose, connect the Air suction hole of sensor hopper (SVH) to the current air inlets of the SAL-900GE. Then connect the material inlets of Hopper dryer to the sensor hopper(SVH).

### SAL-900GM Series

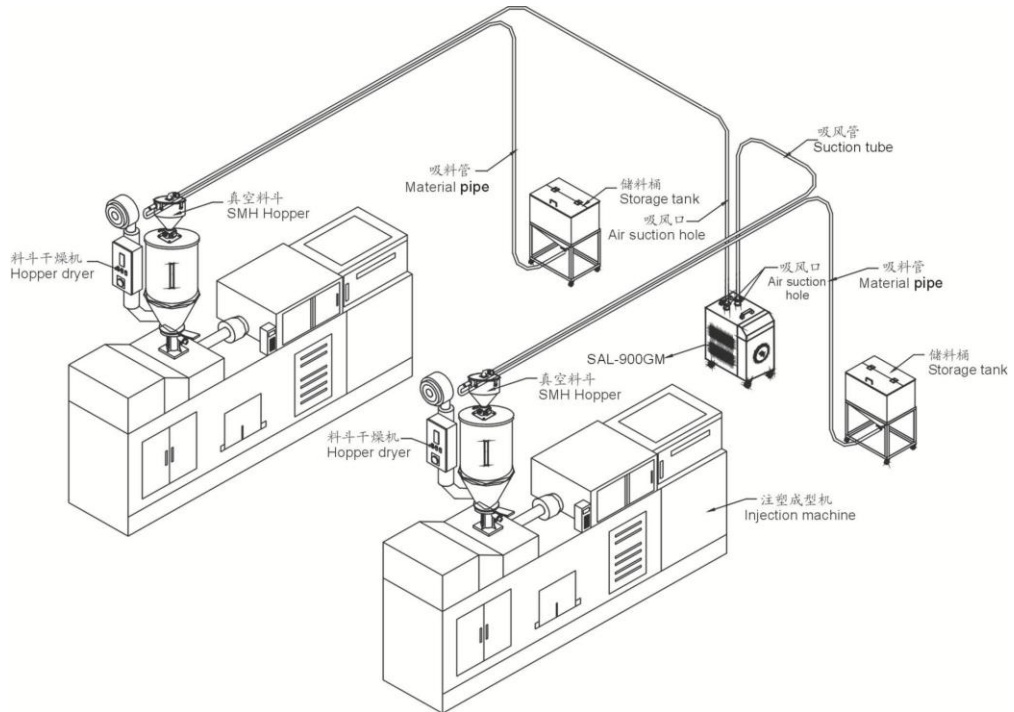

### 安装步骤:

- 将 SAL-900GM 放置于合适的地方，并连接好电源线。
- 将真空料斗安装于注塑机上，并将信号线接到 SAL-900GM 吸料机上。
- 用钢丝软管分别将真空料斗吸气口连接到对应的 SAL-900GM 吸风口上，并将真空吸料口连接到储料桶。

### INSTALLATION:

- Place the SAL-900GM machine at a proper position on the ground, Connect the three phase power cord and the earth.
- Install the Material hopper(SMH) on the hopper dryer. Connect the signal

cord to the machine SAL-900GM.

3. Use the steel wire soft hose, connect the Air suction hole of material hopper (SMH) to the current air inlets of the SAL-900GM. Then connect the material inlets of storage tank to the material hopper(SMH).

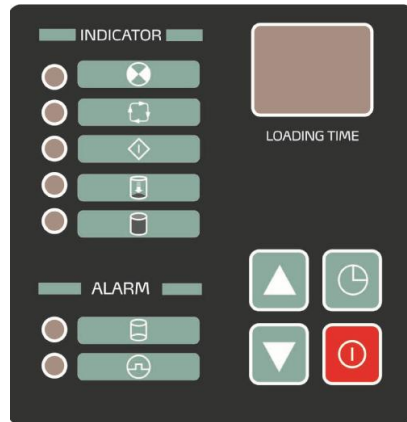

## 8. 操作说明 Operation

### 8.1 SAL-700G/800G 操作说明 Operation



SAL-700G/800G

#### 操作方法

1. 按  键，设定吸料时间于适当值，一般原料设定为 20 秒左右。
2. 按  开机，即能自动进行填料。欲关机时，再按一次  键即可停止作业。

#### 注意事项

1. 本机在无料可吸时即自动停止并发出警报声，此时按  键关机，待加料后或故障排除后再开机即能恢复正常作业。
2. 请定期清除空气过滤器及料斗滤网以保持吸料顺畅。

#### 功能设定

按  键来选择吸料功能



C1=自动缺料报警

C2=先喷洗滤网，5 秒后或 5 秒预备时间后自动吸料，缺料警报。(选购功能)

C3=有马达自动逆转除尘功能。(此功能仅适用于 SAL-400 系列)

C4=自动吸料，连续吸三次无料才输出缺料警报。

## OPERATION

1. Press  button then the current function status will be displayed, Press  button to set the loading time(20 seconds for general materials).
2. Press  button and the operation will proceed automatically. Press again to stop.

## NOTES

1. When running out of material, the machine will stop and sound the alarm.  
Turn off the switch, after refilling the material, then re-start.
2. Check suction filter periodically and clean filter screen if necessary.

## FUNCTION SETTING

Press  button to select function type:

C1=automatic loading with material-shortage alarm.

C2=5sec. Automatic filter cleaning or loading preparation with material-shortage alarm(optional)

C3=automatic reverse running of motor for dust cleaning before loading with material-shortage alarm.( For SAL-400 series only)

C4=automatic loading with alarm after 3 times of continual material-shortage.

## 8.2 功能设定 Function Setup

### 8.2.1 设定方法 Setup

### 设定模式及吸料时间

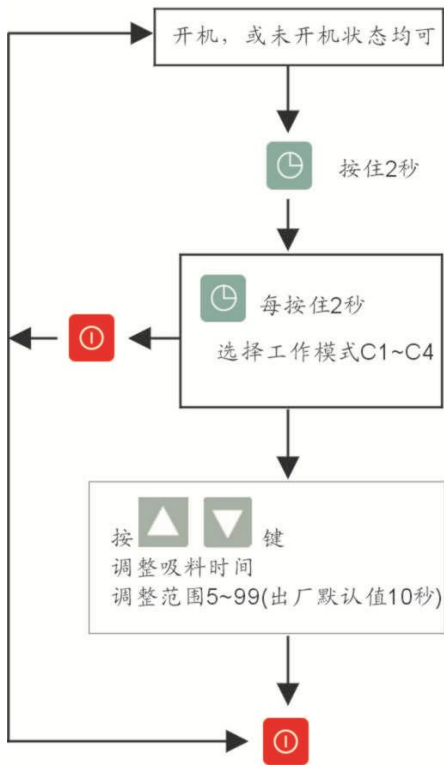

### 设定进阶参数

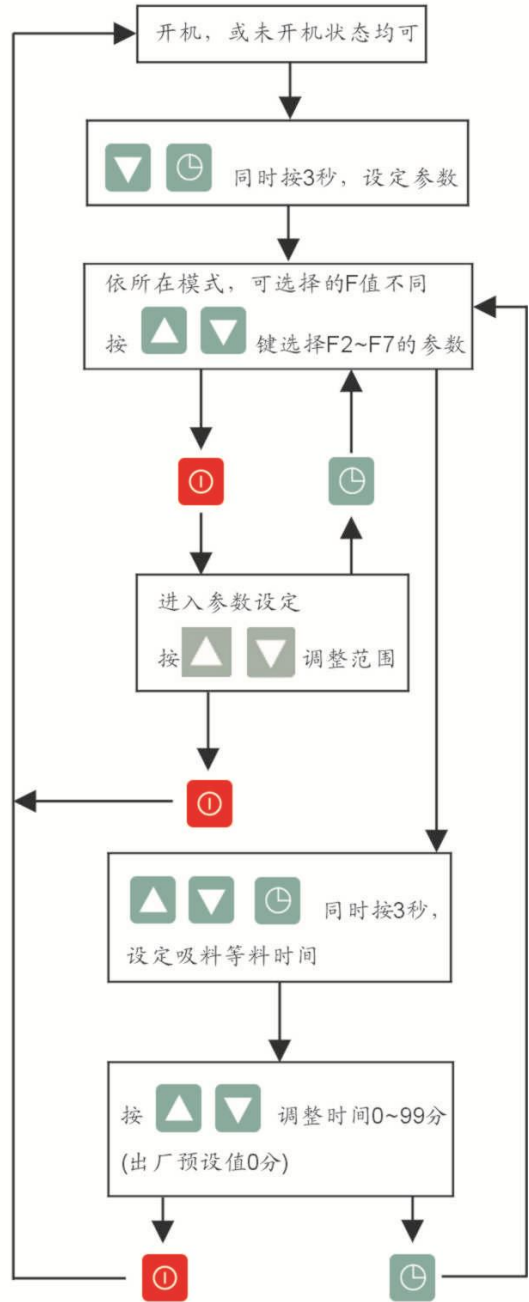

Setup loading mode and time

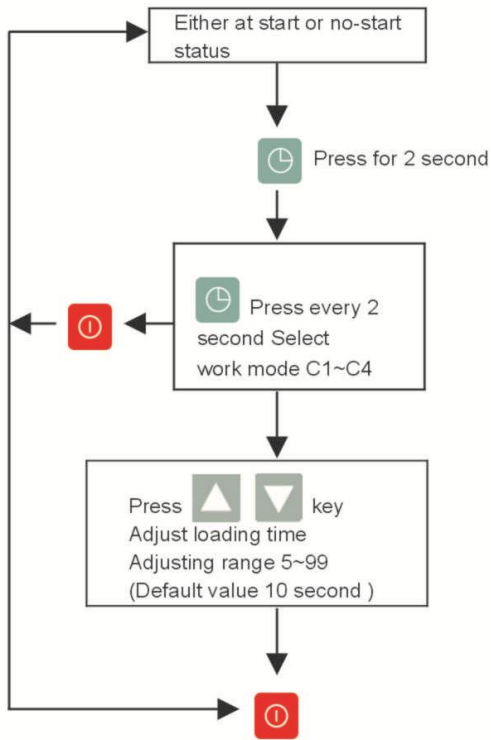

Setup advanced parameters

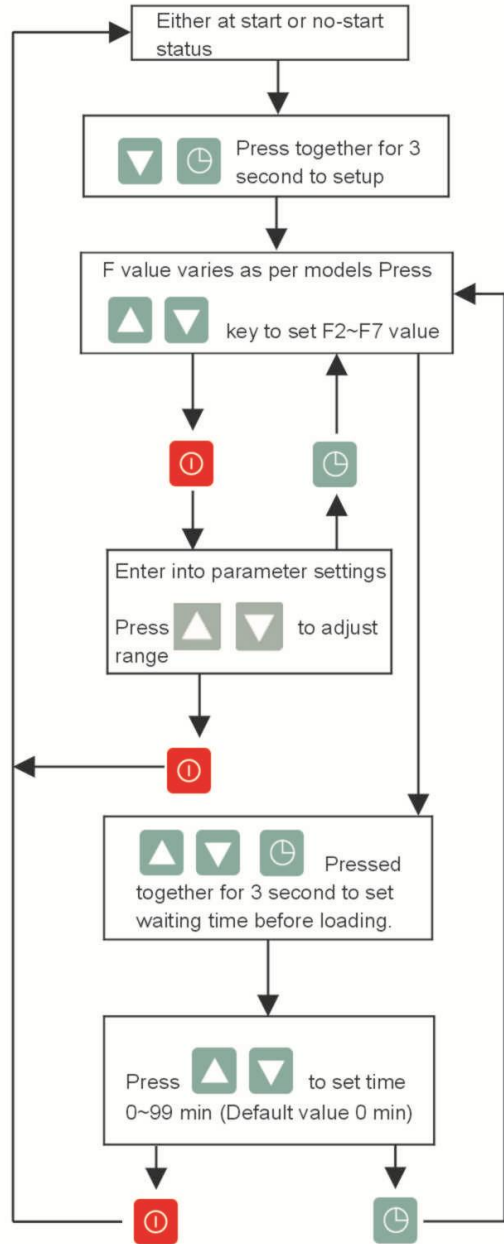

## 8.2.2 动作说明 Actions

1. 按下 切换开关机状态。

2. 按  键来选择吸料模式。

C1=自动吸料，吸一次无料时输出缺料报警。

(适用于 SAL-700G/800G 系列)

C2=自动吸料后，按设定周期及次数进行喷洗。

(适用于 SAL-330/360 系列)

C3=有马达自动逆转除尘功能。

(此功能适用于 SAL-430/460 系列)

C4=自动吸料，连续吸三次无料时才输出缺料报警。

(适用于 SAL-700G/800G 系列)

3. 在待机状态下时，七段显示器显示吸料时间。

4. 动作流程。

1. Press down  to switch between start / stop status.

2. Press  key to select loading mode.

C1=Auto loading, material shortage alarms whenever no material being loaded. (Applicable to SAL-700G / 800G models)

C2=After auto loading, purge as per set period and times.

(Applicable to SAL-330 / 360 models)

C3=Motor reverse running for dust separating.

(Applicable to SAL-430 / 460 models)

C4=Auto loading, material shortage alarms after three time no material being loaded. (Applicable to SAL-700G / 800G models)

3. At standby state, the seven sectional display will display loading time.

4. Action flow.

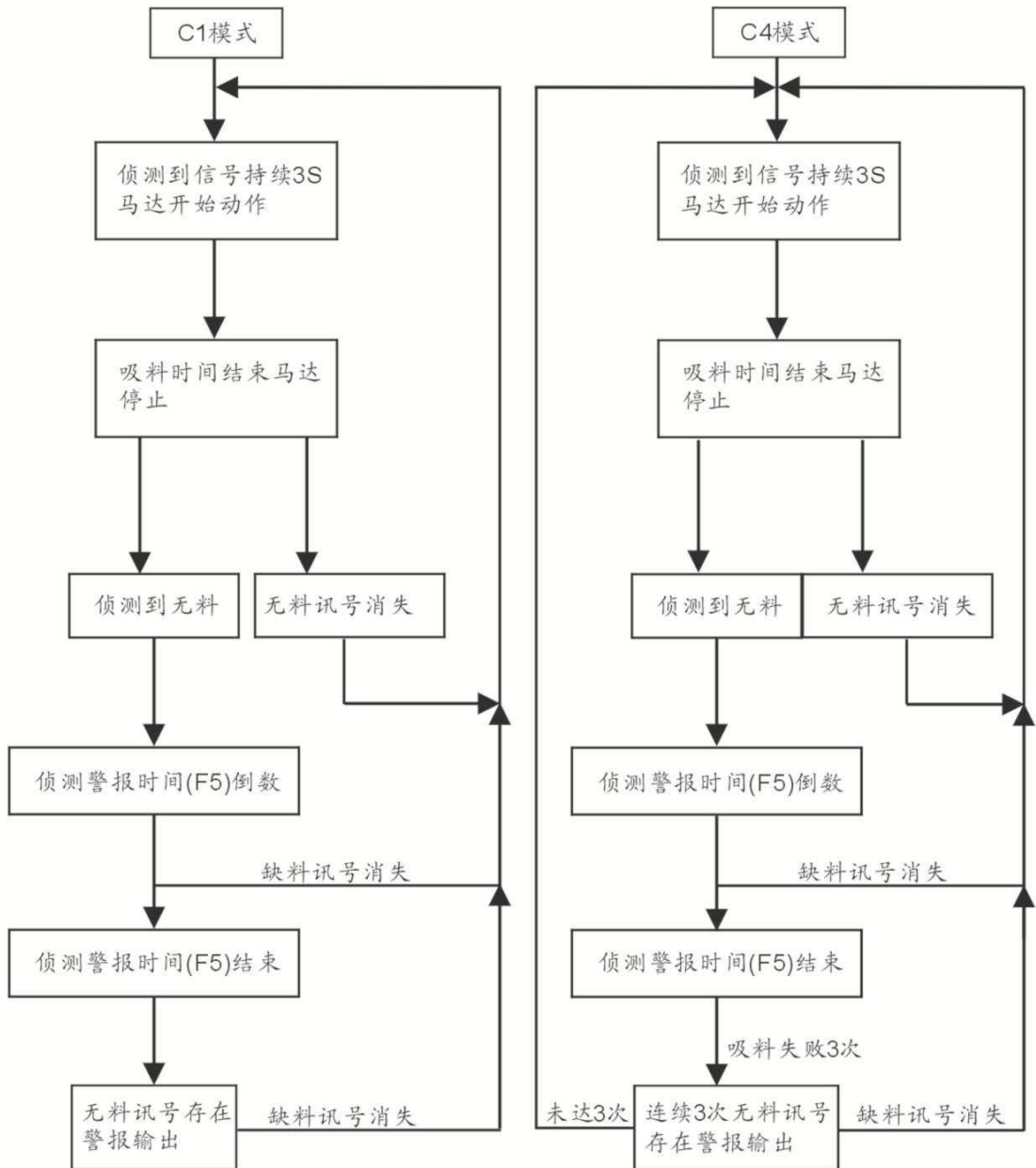



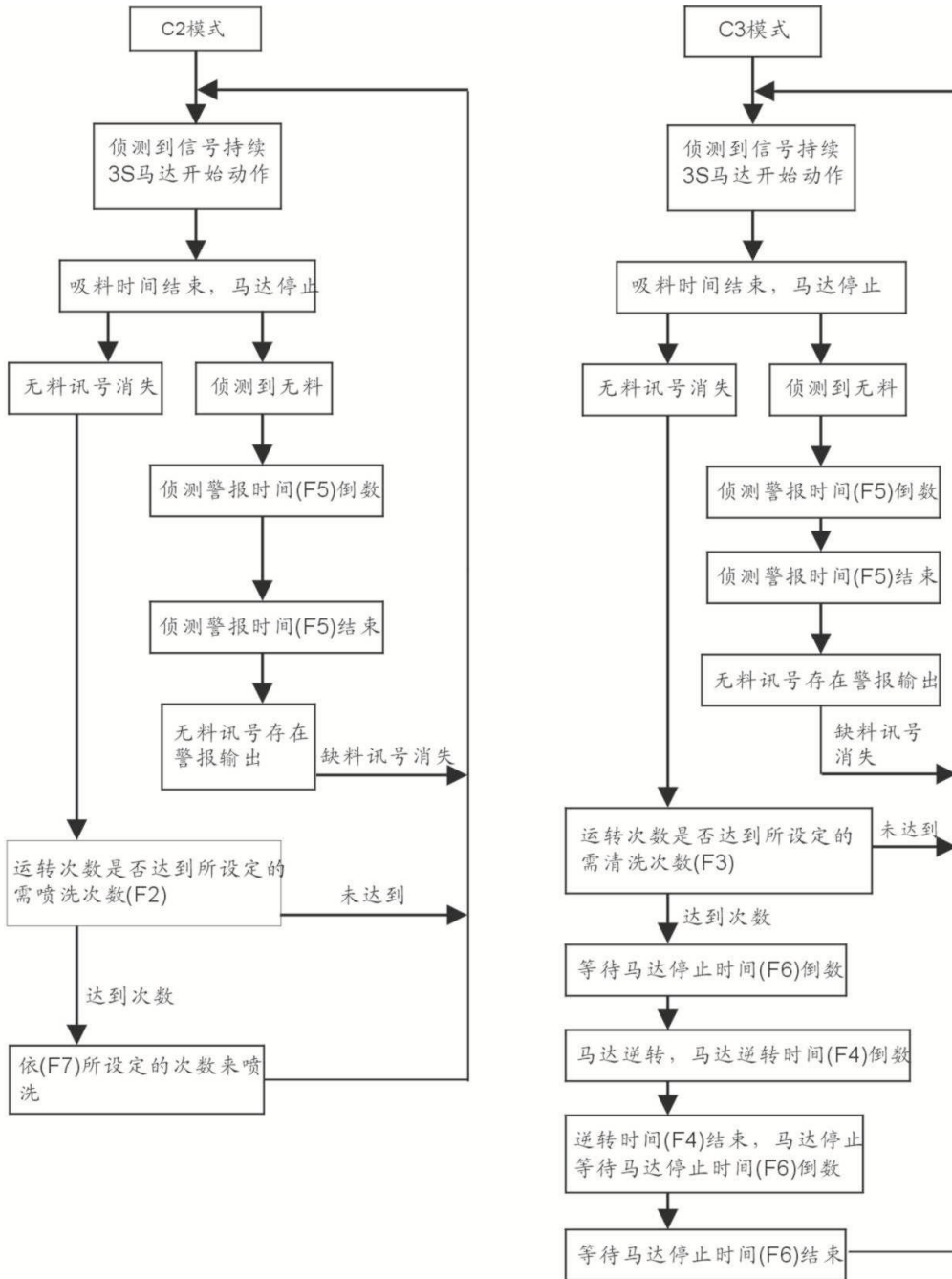

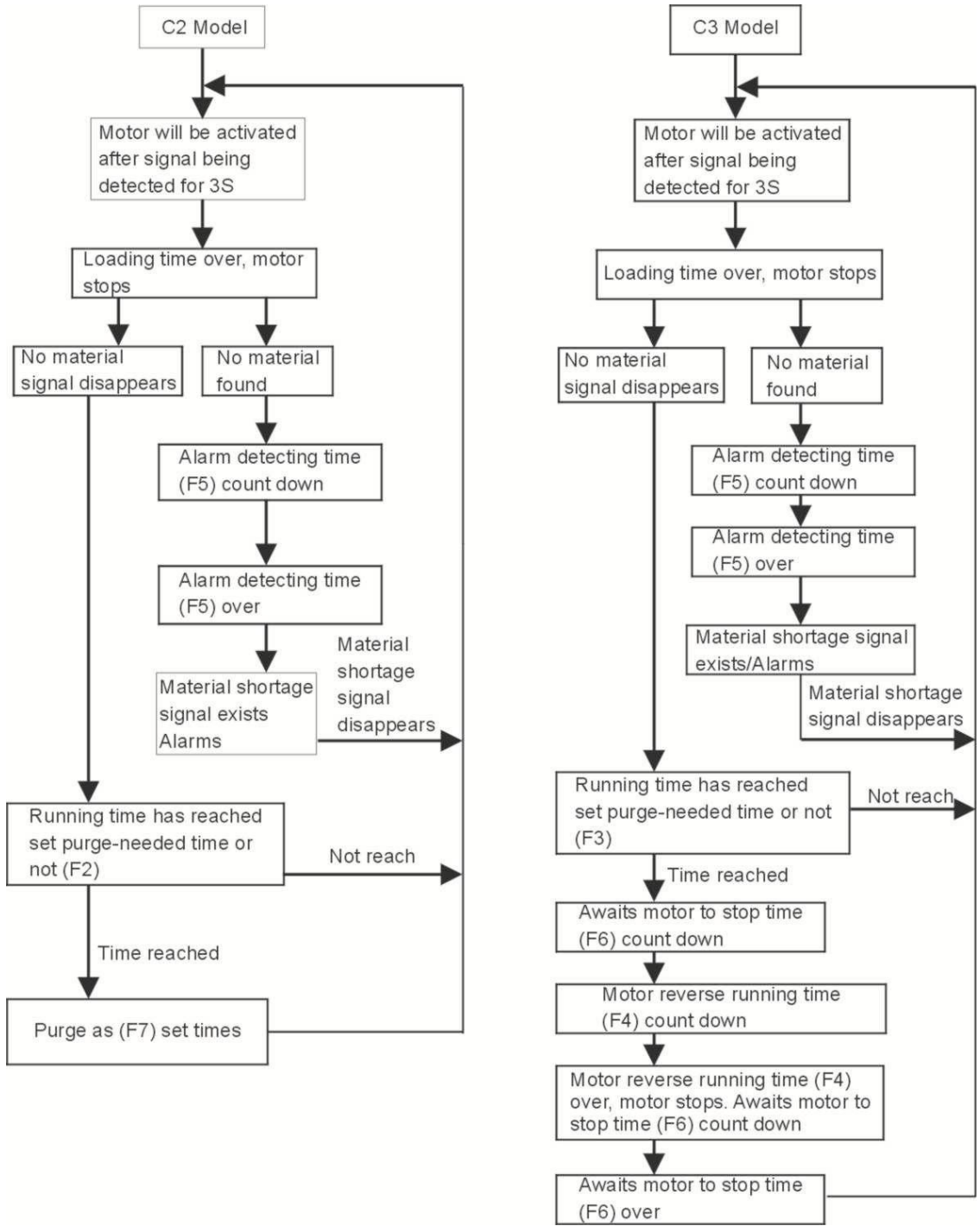

### 8.2.3 参数说明 Parameter List

F2：运转几次需喷洗的次数，出厂值 3 次-----调整范围 1~10 次。

(适用 C2)

F3：运转几次需逆转清洗的次数，出厂值 3 次-----调整范围 1~10 次。

(适用 C3)

F4：马达逆转时间，出厂值 10 秒-----调整范围 5~30 秒。

(适用 C3)

F5：侦测警报时间，出厂值为 20 秒-----调整范围 10~40 秒。

(适用 C1,C2,C3,C4)

F6：等待马达停止时间，出厂为 30 秒-----调整范围 30~99 秒。

(适用 C3)

F7：喷洗次数，出厂为 2 次-----调整范围 1~5 次。

(适用 C2)

F8：吸料等待时间，出厂为 0-----调整范围 0~99 次。(单位：分钟)

在 C1 时, 可设定 F5、 F8。

在 C2 时, 可设定 F2, F5, F7、 F8。

在 C3 时, 可设定 F3, F4, F5, F6、 F8。

在 C4 时, 可设定 F5、 F8。

F2 : To purge for every how many running times, default value is 3 times-----adjusting range1~10 times. (Applicable to C2)

F3 : Motor reverse running for cleaning for every how many running times, default value is 3 timesadjusting range 1~10 time. (Applicable to C3)

F4 : Motor reverse running time, default value is 10 second-----  
Adjusting range 5~30 second. (Applicable to C3)

F5 : Alarm detecting time, default value is 20 second-----Adjusting range 10~40 second. (Applicable to C1,C2,C3,C4)

F6 : Awaits motor to stop time, default value is 30 second-----Adjusting range 30~99 second. (Applicable to C3)

F7 : Purge times, default value is 2 times-----Adjusting range 1~5 times.  
(Applicable to C2)

F8 : Loading latency time, and default value is 0-----Adjusting range 0~99

times. (per minute)





To set F5 and F8 at C1.

To set F2, F5, F7 and F8 at C2.

To set F3, F4, F5, F6 and F8 at C3.

To set F5 and F8 at C4.

#### 8.2.4 其它设定 Other settings

1. 未开机时的任何设定，若等待 5 秒不动作，自动回到关机状态，所设定的参数自动储存。
  2. 开机后的任何设定，若等待 5 秒不动作，自动回到待机状态，所设定的参数自动储存。
  3. 在一切动作结束后，且未侦测到有缺料讯号时，若把   键同时按 3 秒以上不放，此时马达会进入逆转喷洗动作，当放开   后马达停止，等待马达停止时间倒数，倒数结束后，回到待机下侦测缺料信号。
  4. 短接片的功能：当短接后，可选择 C1、C3、C4 功能，适合于 SAL-700G/800G/430/460 机型。当断开后，只可选择 C1、C2、C4 功能，适合于 SAL-700G/800G/330/360 机型。
1. Any setting before power on will be saved automatically and back to shut off state after 5 second of no operation.
  2. Any setting after power on will be saved automatically and back to standby state after 5 second of no operation.
  3. No material shortage signal is being detected even after all action is over,

then if press ▲▼ key for 3 second, motor will perform reverse running action, when release the ▲▼ keys to stop motor and await the motor stop count down and back to standby state to detect material shortage signal.

- Function of the jumper: functions of C1, C3 and C4 will be activated when jumping out which is applicable to SAL-700G/800G/430/460. When disconnected, only functions of C1, C2 and C4 are available which can be used for SAL-700G/800G/330/360.

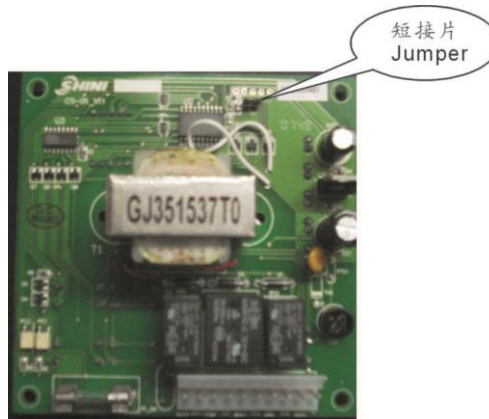



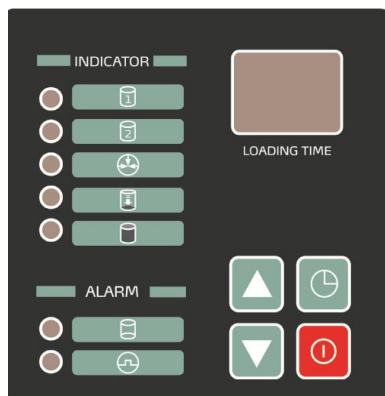



### 8.3 SAL-900G 操作说明 Operation

















#### 操作方法:OPERATION

- 通入电源, LED 显示"--"进入吸料时间设定。

2. 按  键，料斗 1 指示灯呈红色，按  键设定料斗 1 吸料时间。
3. 再按  键，料斗 2 指示灯呈红色，按  键设定料斗 2 吸料时间。
4. 再次按  键，阀门指示灯呈红色，按  键设定截料阀放料时间。

(截料阀为选购品，其功能详见第 11 页)



5. 设定完毕，按  键确定；
6. 按一次  料斗 1 自动运行工作，再按一次  料斗 1 及料斗 2 自动运行工作；  
按三次  仅料斗 2 自动运行工作；按四次  关机。

1. Connect the power supply, "--" is displayed on LED, then enter to set loading time.
2. Press key "", the lamp of LOAD1 is red. Then press key "" to set the loading time of LOAD1.
3. Press the key "" again, the lamp of LOAD2 is red. Then press the key "" to set the loading time of LOAD2.
4. Press the key "" once more, the lamp of GATE is red. Then press the key "" to set the loading time of shut-off valve.(Shut-off valve is option, its function see page 11)
5. After setting, press key "" to confirm.
6. Press once the key "", the LOAD1 will auto-working. Press twice the key "", both the LOAD1 and LOAD2 will auto-working. Press three times the key "", only the LOAD2 will auto-working. Then press four times the key "", the machine is stop.

## 注意事项 NOTES

1. 本机于无料可吸或马达过载即自动停止发出警报声，此时按  键停止作业，待

加料后再按  键始能恢复正常作业。

2. 定期检查并清洗空气过滤网以保持吸料顺畅。
1. When running out of material, or the motor is overload, the operation will auto-stop and sound the alarm. Press  button for closing the alarm sound and stoppage. After refilling the material, Press the  button to start the operation.
2. Check suction filter periodically and clean filter screen if necessary.

## 9. 清洁保养 Maintenance

### 9.1 料斗的清洁 Hopper cleaning

真空料斗的清洁：储料斗内皆装有过滤网，请定期或发现吸料量减少时，将储料斗上之弹簧扣放松，卸下桶盖，取出过滤网，消除附着于上面的尘粉，使其保持通气良好，吸力增强。

电眼料斗的清洁：1 清洁过滤网，请定期或发现吸料量减少时，将储料斗上弹簧扣放松，卸下桶盖，取出过滤网，消除附着于上面的粉尘，使其保持良好，吸力增强。2 清洁玻璃管，当发现玻璃管有原料附着时，请及时清除附着的原料，以便于机器正常工作。

SMH Cleaning: In order to avoid air-blocking and to get smooth conveying. Clean the filter screen inside of material. Undo the snap link on the material hopper, remove the cover and take out the filter, then clean it. Clean the filter periodically or when the suction force is reduced.

SVH Cleaning: Clean the filter, In order to avoid air-blocking and to get smooth conveying. Clean the filter screen inside of material. Undo the snap link on the material hopper, remove the cover and take out the filter, then clean it. Clean periodically or when the suction force is reduced Clean the glass tube, when the material accrete on the tube, Clean the material in time, So that the machine work normal.

### 9.2 主体的清洁 Main body cleaning

使用中，请定期或发现吸料量减少时，取出主体上之滤清器，清除附着于上面的尘粉，使其保持通气良好状况，吸力增强。

清洁除尘步骤：

- 1、松开弹簧扣卸下主体上之滤清器护罩，松开蝶型螺帽，即取出滤清器。
- 2、将滤清器上之积尘清除，保持良好吸力。

Clean the suction filter regularly to avoid clogging which will affect the loading capacity.

Step to clean filter:

1. Release the spring catch, remove the filter cover, and release the nut.
2. Take out the filter, and clean it to ensure strong suction.

过滤器的检查和集尘桶的清扫

Filter Inspection and Storage Hopper Cleanup

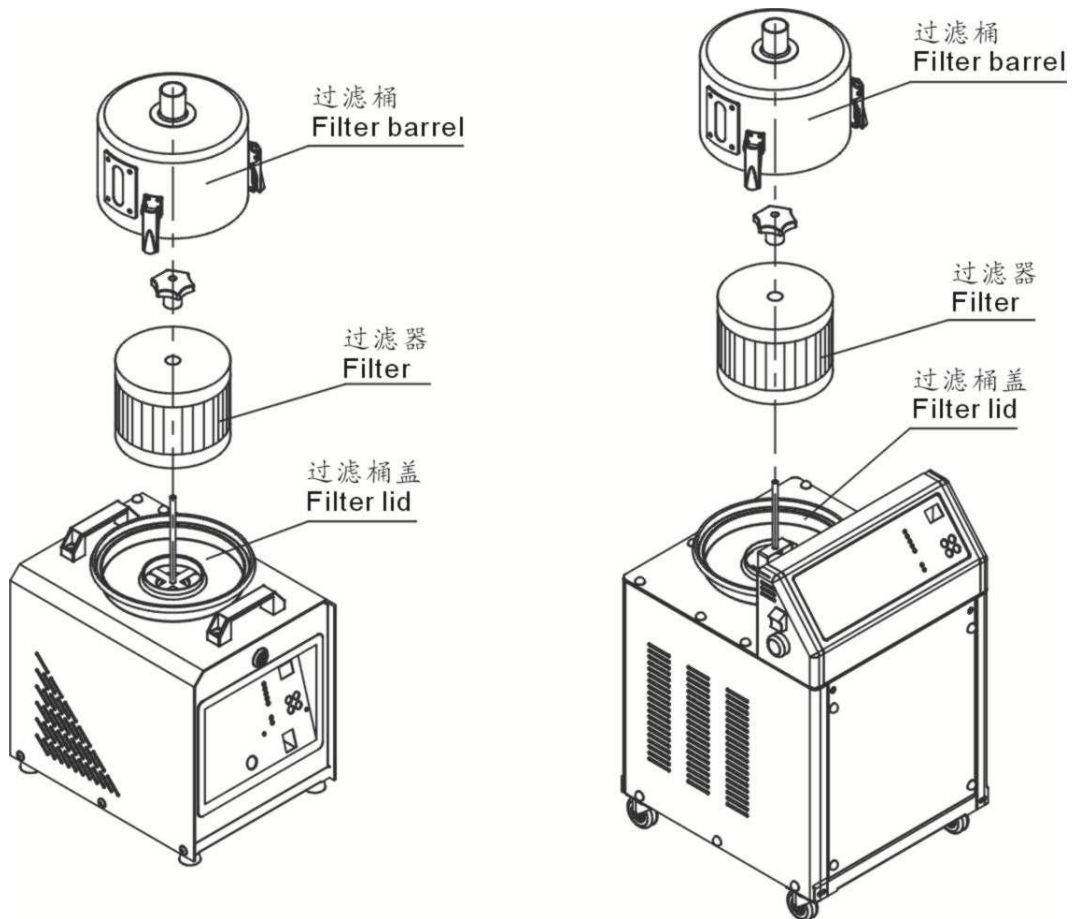

1. 打开弹簧扣，取下过滤桶，取出过滤器，采用高压气枪从过滤器里面往外面吹掉其上面的灰尘，取下过滤桶盖，清扫里面的灰尘。

2. 过滤器清扫。周期：每日

1. Loosen the snap hook, release the filter barrel and take out the filter; blow off the dust with a high pressure air gun from the inside to outside; take down the filter barrel lid and remove the dust in it.

2. Clean the filter. Period: daily

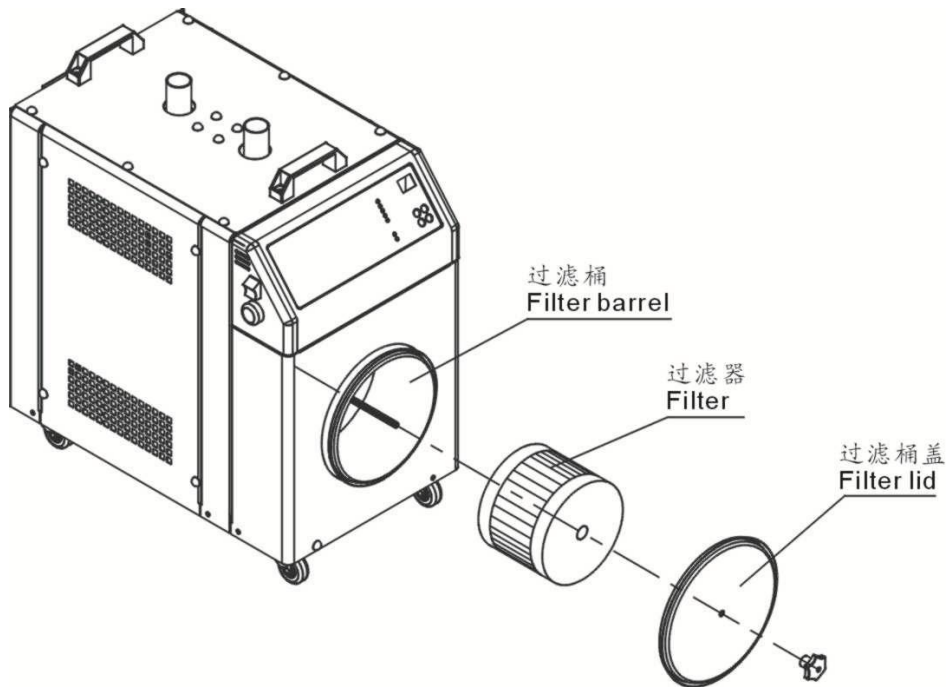

1. 取下过滤桶盖，取出过滤器，采用高压气枪从过滤器里面往外面吹掉其上面的灰尘，并清扫过滤桶里面的灰尘。

2. 过滤器清扫。周期：每日。

1. Open the filter barrel lid and take out the filter; blow off the dust with a high pressure air gun from the inside to outside; take down the filter barrel lid and remove the dust in it.

2. Clean the filter. Period: daily

## 10. 故障排除 Troubleshooting

故障现象 Fault	产生的原因 Possible reasons	排除方法 Solution
缺料很长时间 吸料风机不工作 When shortage lasts long, but suction blower don't run.	主电源开关及控制开关没打开 或主电源开关及控制开关触点接触不良 The main switch and control switch don't open or the above two don't connect well.	闭合主电源开关及控制开关及检查开关触点是否良好 Close the main switch and control switch and check their connecting.
	料斗微动开关接触不良 The microswitch on hopper don't connect well .	调整或更换 Adjust or replace.
	信号线断 The signal wire is break.	重接 Re-connect.
料已满吸料风机继续工作 The suction blower still run, if the hopper is full.	接触器触点粘合 The touch point is conglutinated	修整或更换接触器 Repair or replace.
连续几次吸不满料 或缺料报警发生 After several times of loading the material hopper still empty or the material shortage alarm occur.	原料已用完 The storage tank is empty.	添加原料 Add the material
	风管漏气 The pipe is air leak.	锁紧或更换风管 Lock tightly and replace the vacuuming pipe.
	过滤器堵塞 The filter is block.	清理过滤器 Clean the filter.
马达不运转 The motor can't run.	缺相或马达烧坏 Short-phase or motor was burnt out.	检查更换 Check and replace.
开启后一直烧保险 The fuse always was burn out after start-up.	有短路或接地现象 Short circuit or connect the ground.	检查线路 Check the circuit.
马达过载警报发生 Motor overload alarm occur	过滤器堵塞 The filter is block.	清理过滤器后, 按下负载器上 Reset 键 Clean the filter and reset the overload relay.
	缺相 One of three phase is lacking.	检查线路后按下负载器上的 Reset 键 Check the circuit and reset the overload relay.

# 11. 电路图 Electric diagram

## 11.1 SAL-700G 电路图 Electric diagram(1 Φ 200~230V 50/60Hz)

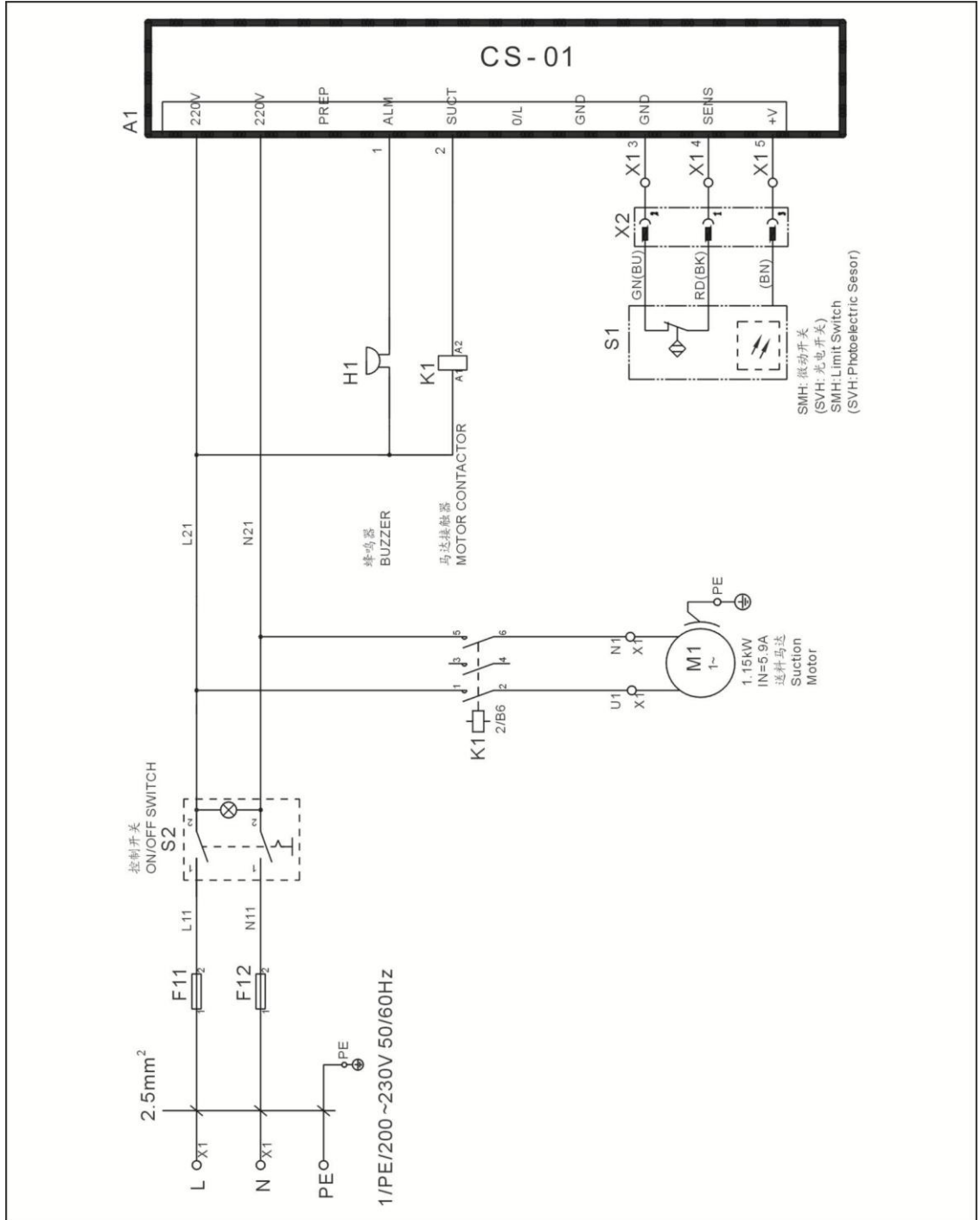

## 11.2 SAL-700G 组件布置及端子接线图 Layout and Component Video Wiring Diagram (1 $\Phi$ 200~230V 50/60Hz)

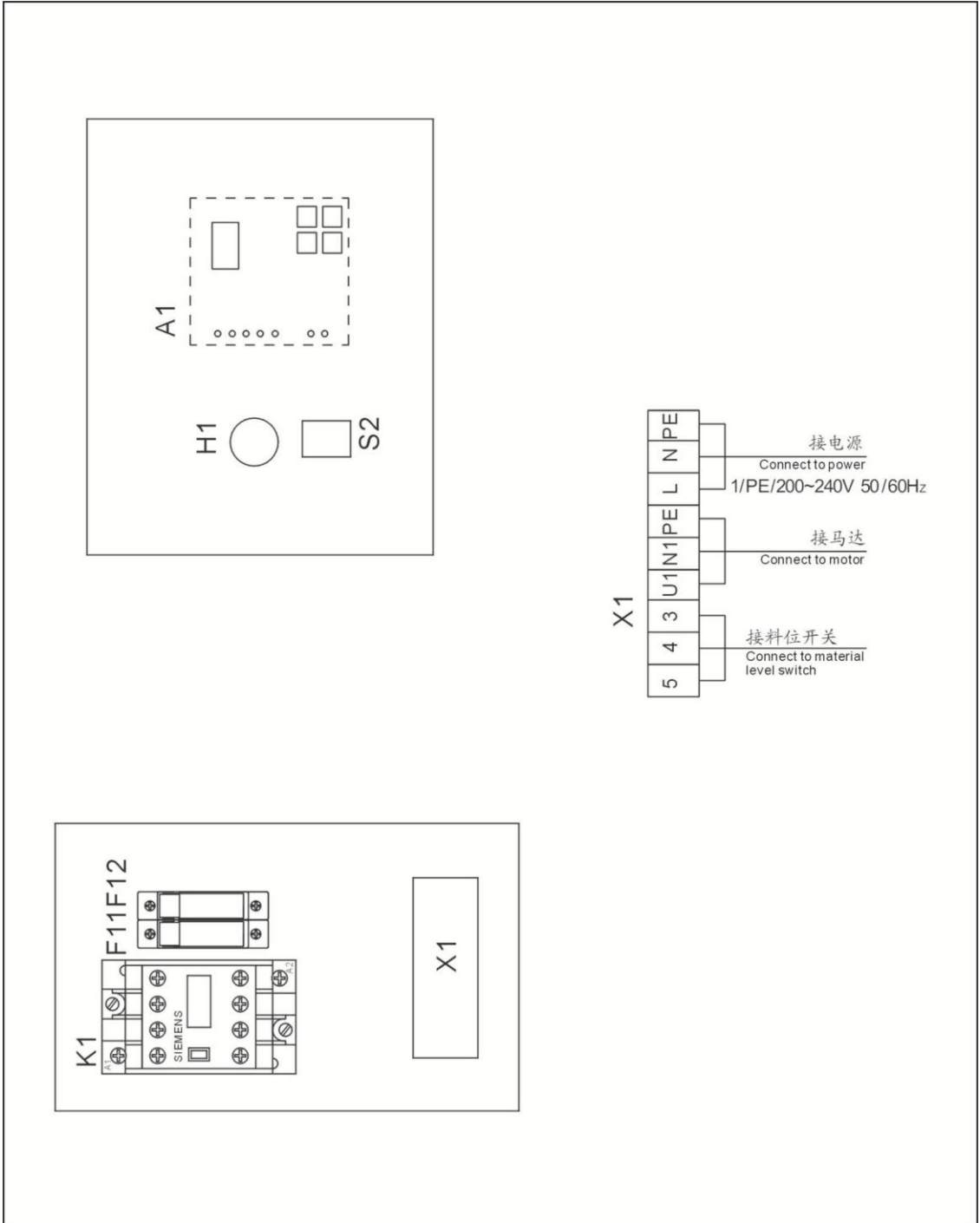

### 11.3 SAL-700G 电气组件明细 Bill of Electrical Parts

序号 No.	符号 Symbol	名称 Parts Name	规格 Seecifications	物料编号 Parts No.
1	F11 F12	熔断器座 Fuse Box**	500VAC 10A	
2	-	熔芯 Fuse**	10*38 10A 500V	
3	K1	接触器 Contactors **	230VAC 50/60Hz	
4	H1	蜂鸣器 Buzzer	230VAC 50/60Hz	
5	PC	线路板 Circuit Board	230VAC 50/60Hz	
6	S1	微动开关 Micro-I Switch	400V 10A	
7	-	光电开关 Photoelectric Switch	10~30VDC	
8	S2	控制开关 Control Switch	400V 10A	
9	X1	端子排 Terminal Board	25A	
10	X2	金属接头 Port	250V 10A 3P	
11	M1	马达 Motor	1.15kW 240VAC 50/60H	

\*表示可能损坏的项目；\*\*表示较可能损坏的项目，建议备份。

请在下单采购零配件之前，先确认说明书版本号，以确保零配件物料号与实物一致。

\* means possible broken parts.

\*\* means easy broken part. and spare backup is suggested.

Please confirm the version of manual before placing the purchase order to guarantee that the item number of the spare part is in accordance with the real object.

# 11.4 SAL-800G 电路图 Electric diagram (3Φ 400V 50/60Hz)

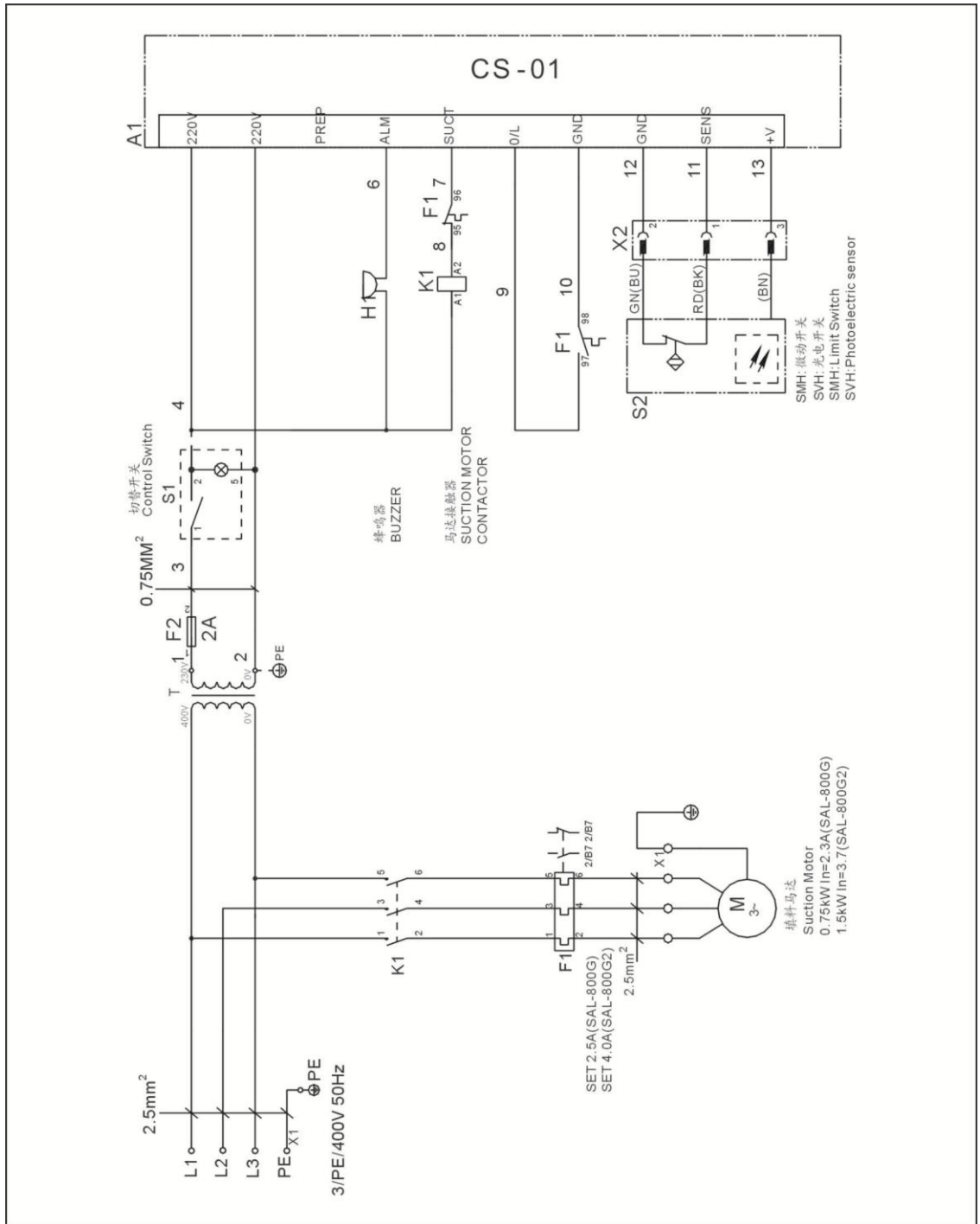

# 11.5 SAL-800G 组件布置及端子接线图 Layout and Component Video Wiring Diagram (3Φ 400V 50/60Hz)

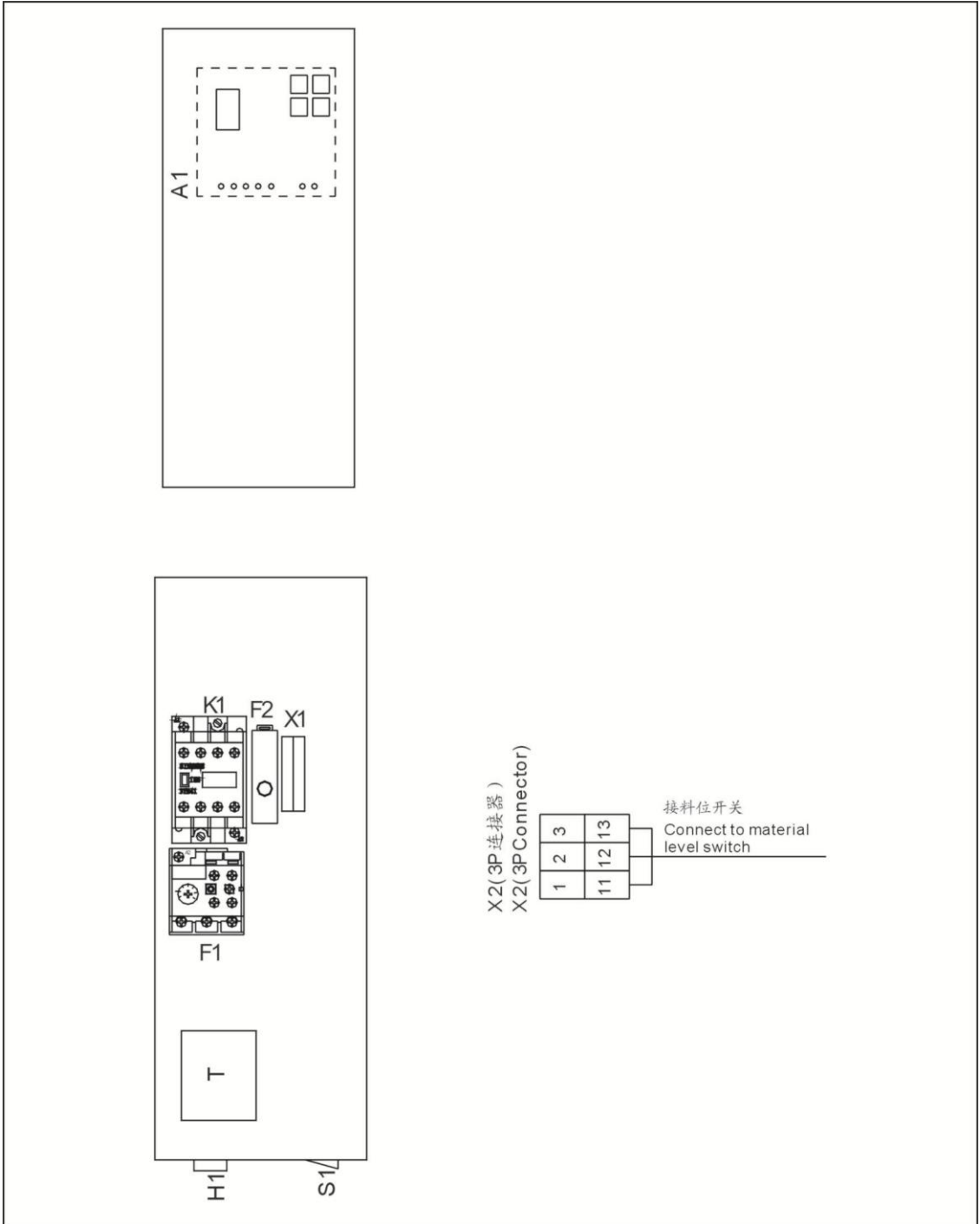

## 11.6 SAL-800G 电气组件明细 Bill of Electrical Parts

序号 No.	符号 Symbol	名称 Parts Name	规格 Seecifications	物料编号 Parts No.
1	K1	交流接触器 AC Contactors	230V 50/60Hz	
2	F1	热过载继电器 Overload Relays	2~3.2A	
3	T	互感变压器 Transformer	300mA	
4	F2	熔断器 Fuse	2A 熔芯 Fuse	
5	S1	控制开关 Control Switch	250VAC 10A	
6	S2	微动开关 Micro-I Switch	250V 10A	
7	-	光电开关 Photoelectric Switch	10~30VDC	
8	H	蜂鸣器 Buzzer	230VAC 50/60Hz	
9	X1	端子排 Terminal Board	-	
10	X2	金属接头 Port	250V 10A 3P	
11	M1	马达 Motor	1HP	

\*表示可能损坏的项目；\*\*表示较可能损坏的项目，建议备份。

请在下单采购零配件之前，先确认说明书版本号，以确保零配件物料号与实物一致。

\* means possible broken parts.

\*\* means easy broken part. and spare backup is suggested.

Please confirm the version of manual before placing the purchase order to guarantee that the item number of the spare part is in accordance with the real object.

## 11.7 SAL-800G2 电气组件明细 Bill of Electrical Parts

序号 No.	符号 Symbol	名称 Parts Name	规格 Seecifications	物料编号 Parts No.
1	K1	交流接触器 AC Contactors	230V 50/60Hz	
2	F1	热过载继电器 Overload Relays	3.5~5A	
3	T	互感变压器 Transformer	300mA	
4	F2	熔断器 Fuse	2A 熔芯 Fuse	
5	S1	控制开关 Control Switch	250VAC 10A	
6	S2	微动开关 Micro-I Switch	250V 10A	
7	-	光电开关 Photoelectric Switch	10~30VDC	
8	H	蜂鸣器 Buzzer	230VAC 50/60Hz	
9	A1	微电脑主板 Microcomputer Mainboard	230VAC 50/60Hz	
10	X1	端子排 Terminal Board	-	
11	X2	金属接头 Port	250V 10A 3P	
12	M1	马达 Motor	2HP	

\*表示可能损坏的项目；\*\*表示较可能损坏的项目，建议备份。

请在下单采购零配件之前，先确认说明书版本号，以确保零配件物料号与实物一致。

\* means possible broken parts.

\*\* means easy broken part. and spare backup is suggested.

Please confirm the version of manual before placing the purchase order to guarantee that the item number of the spare part is in accordance with the real object.

# 11.8 SAL-900G 电路图 Electric diagram (3Φ 400V 50/60Hz)

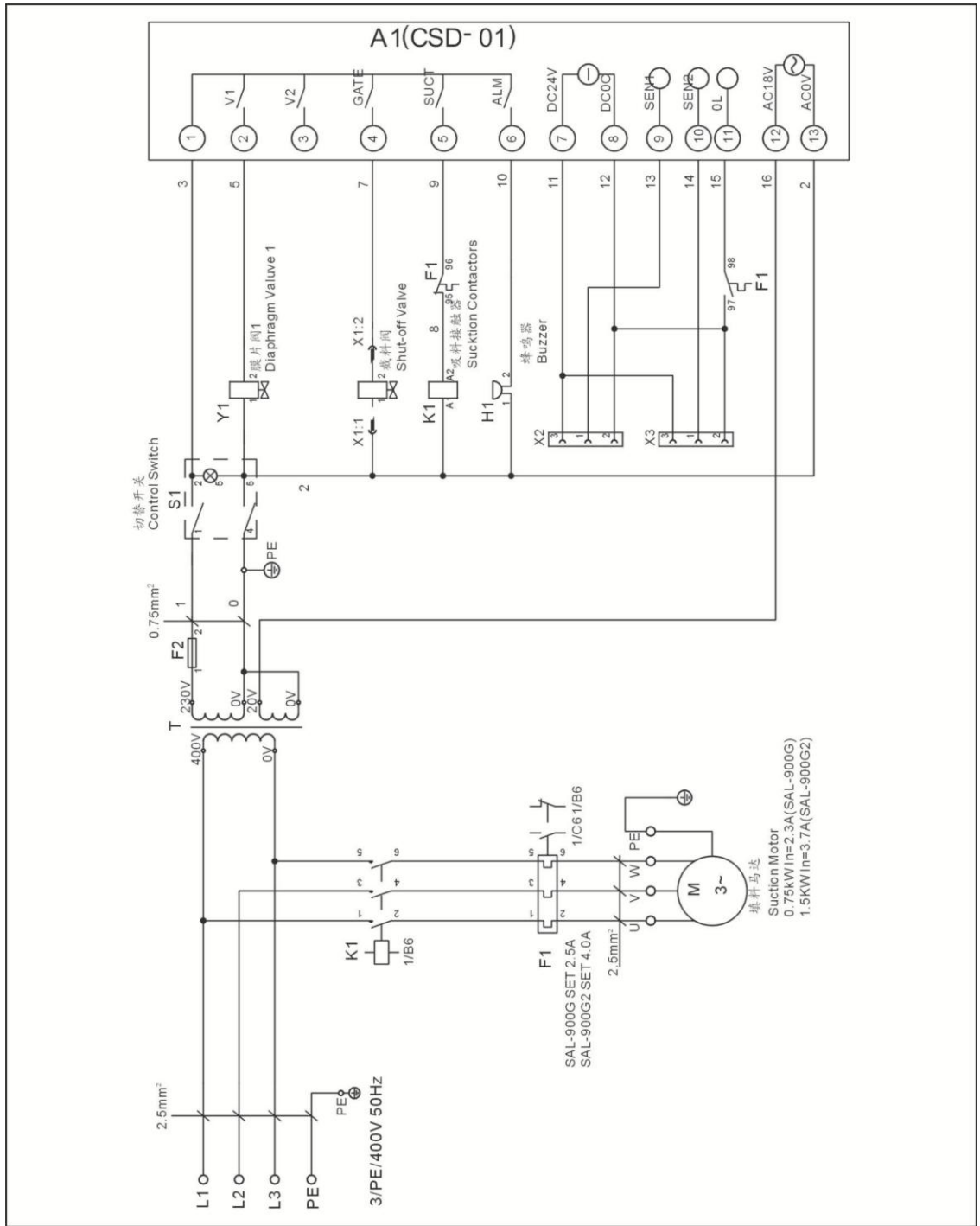

# 11.9 SAL-900G 组件布置及端子接线图 Layout and Component Video Wiring Diagram (3Φ 400V 50/60Hz)

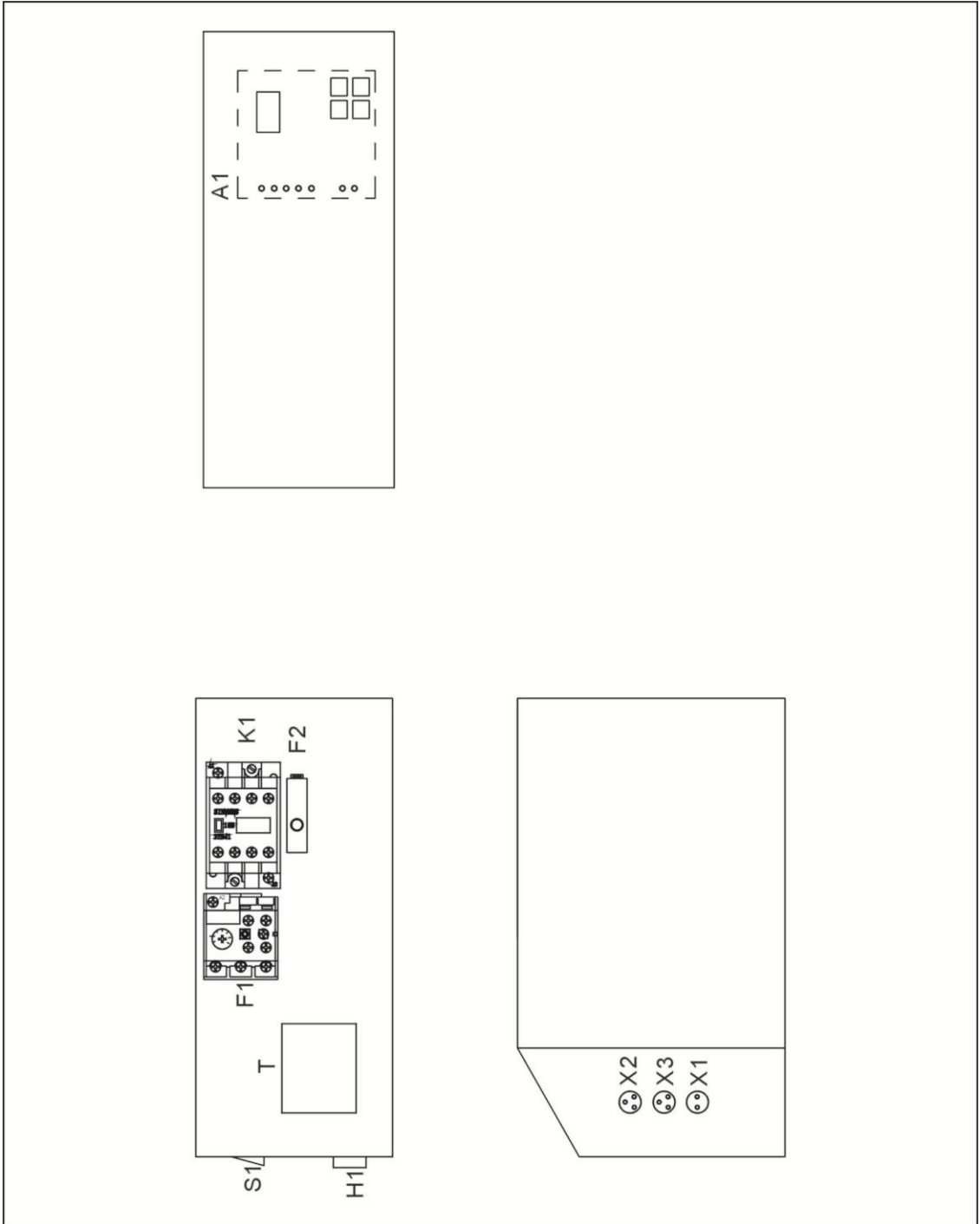

## 11.10 SAL-900G 电气组件明细 Bill of Electrical Parts

序号 No.	符号 Symbol	名称 Parts Name	规格 Seecifications	物料编号 Parts No.
1	K1	交流接触器 AC Contactors	230V 50/60Hz	YE00300000000
2	H1	蜂鸣器 Buzzer	60-250VAC	YE84003500000
3	F1	热过载继电器 Overload Relays	2-3.2A	YE01023200000
4	T	变压器 Transformer	500mA	YE70504000000
5	F2	熔断器座 Fuse Box	250V 2A	YE41001000000
6	S1	切替开关 Control Switch	4P (WH)	YE10210400000
7	Y1	电磁阀 Solenoid Valve	230V 50/60Hz	YE32051800300
8	A1	线路板 Circuit Board	18VAC 50/60Hz	YE80101100000
9	X1	金属接头 Port	250V 10A 2P	YE68025200300
10	X2 X3	金属接头 Port	250V 10A 3P	YE68025300200
11	M	马达 Motor	1HP	-

\*表示可能损坏的项目；\*\*表示较可能损坏的项目，建议备份。

请在下单采购零配件之前，先确认说明书版本号，以确保零配件物料号与实物一致。

\* means possible broken parts.

\*\* means easy broken part. and spare backup is suggested.

Please confirm the version of manual before placing the purchase order to guarantee that the item number of the spare part is in accordance with the real object.

## 11.11 SAL-900G2 电气组件明细 Bill of Electrical Parts

序号 No.	符号 Symbol	名称 Parts Name	规格 Seecifications	物料编号 Parts No.
1	K1	交流接触器 AC Contactors	230V 50/60Hz	YE00300000000
2	H1	蜂鸣器 Buzzer	60-250VAC	YE84003500000
3	F1	热过载继电器 Overload Relays	3.5-5A	Ye01032500000
4	T	变压器 Transformer	500mA	YE70504000000
5	F2	熔断器座 Fuse Box	250V 2A	YE41001000000
6	S1	切替开关 Control Switch	4P (WH)	YE10210400000
7	Y1	电磁阀 Solenoid Valve	230V 50/60Hz	YE32051800300
8	A1	线路板 Circuit Board	18VAC 50/60Hz	YE80101100000
9	X1	金属接头 Port	250V 10A 2P	YE68025200300
10	X2 X3	金属接头 Port	250V 10A 3P	YE68025300200
11	M	马达 Motor	2HP	-

\*表示可能损坏的项目；\*\*表示较可能损坏的项目，建议备份。

请在下单采购零配件之前，先确认说明书版本号，以确保零配件物料号与实物一致。

\* means possible broken parts.

\*\* means easy broken part. and spare backup is suggested.

Please confirm the version of manual before placing the purchase order to guarantee that the item number of the spare part is in accordance with the real object.