

SAL-G

"Standard" Separate-vacuum Hopper Loader

Date: Oct, 2018

Version: Ver.E



Content

1. General Description	5
1.1 Coding Principle	6
1.2 Features	6
1.3 Technical Specifications.....	8
1.3.1 External Dimension	8
1.3.2 Specification	10
1.3.3 Loading Capacity	11
1.4 Safety Regulations	11
1.4.1 Safety Signs and Labels.....	11
1.4.2 Signs and Labels	12
2. Structure Characteristics and Working Principle	13
2.1 Working Principle	13
2.1.1 SAL-700G/810G/820G/830G Working Principle.....	13
2.1.2 SAL-900G/900G2 Working Principle	16
2.2 Options.....	17
3. Installation Layout.....	18
3.1 SAL-700G/810G/820G/830G	18
3.2 SAL-900G/900G2.....	20
3.3 Installation of Vacuum Hopper Receiver SMH Optional Storage Collective Hopper SCH-6L	23
3.4 Installation of SAL-G Optional Proportional Valve.....	23
3.5 Installation of SAL-G Optional Cyclone Dust Separator	24
4. Operation.....	25
4.1 SAL-700G/810G/820G/830G	25
4.1.1 Panel Description	25
4.1.2 Setting Description	26
4.2 SAL-900G/900G2 Operation	29
5. Troubleshooting	31
6. Maintenance.....	32
6.1 Hopper Cleaning	32
6.2 Main Body Cleaning	33

Table Index

Table 1-1: Specification	10
Table 4-1: CS-21 Mosbus Parameter	28
Table 4-2: Control Panel Description (SAL-900G/900G2)	29

Picture Index

Picture 1-1: External Dimension 1	8
Picture 1-2: External Dimension 2	9
Picture 1-3: Loading Capacity.....	11
Picture 2-1: Working Principle 1.....	13
Picture 2-2: Working Principle 2.....	14
Picture 2-3: Working Principle 3.....	15
Picture 2-4: Working Principle (SAL-900G/900G2).....	16
Picture 3-1: Installation Layout 1.....	18
Picture 3-2: Installation Layout 2.....	19
Picture 3-3: Installation Layout 1.....	20
Picture 3-4: Installation Layout 2.....	21
Picture 3-5: Installation Layout 3.....	22
Picture 3-6: Optional SCH-6L Installation Layout	23
Picture 3-7: Optional SPV-U Installation Layout	23
Picture 3-8: Optional ACF-1 Installation Layout.....	24
Picture 4-1: Panel	25
Picture 4-2: Control Panel(SAL-900G/900G2).....	29
Picture 6-1: Hopper Cleaning	32

1. General Description



Please read through this operation manual before using and installation to avoid damage of the machine and personal injuries.



SAL-810G&SMH-6L

1.1 Coding Principle

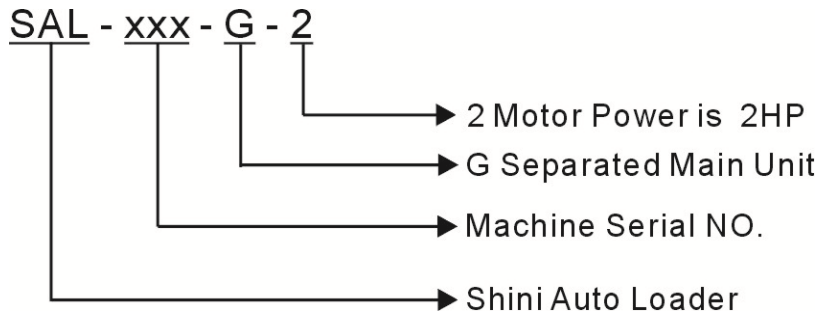

1.2 Features

- Microprocessor for ease of use and has multiple alarm indicators.
- Motor overload protector ensures long service life of motor.
- Audible material shortage alarm.
- Filter designed for easy cleaning and has filter status checking window for easier monitor of filter condition.
- SAL-700G/810G/820G/830G is equipped with RS485 communication interface.

All maintenance work should be carried out by a person with technical training or corresponding professional experience. The manual contains instructions for both operating and maintenance. Chapter 6 contains maintenance instructions for service engineers. Other chapters contain instructions for the daily operator.

Any modifications of the machine must be approved by SHINI in order to avoid personal injury and damage to machine. We shall not be liable for any damage caused by unauthorized change of the machine.

Our company provides after-sales service. Should you have any problem during using the machine, please contact the company or the local vendor.

Headquarter and Taipei factory:

Tel: + 886 (0)2 2680 9119

Shini Plastics Technologies (Dongguan), Inc:

Tel: + 86 (0)769 8111 6600

Email: shini@shini.com

Shini Plastics Technologies India Pvt.Ltd.:

Tel: + 91 250 3021 166.

1.3 Technical Specifications

1.3.1 External Dimension

SMH

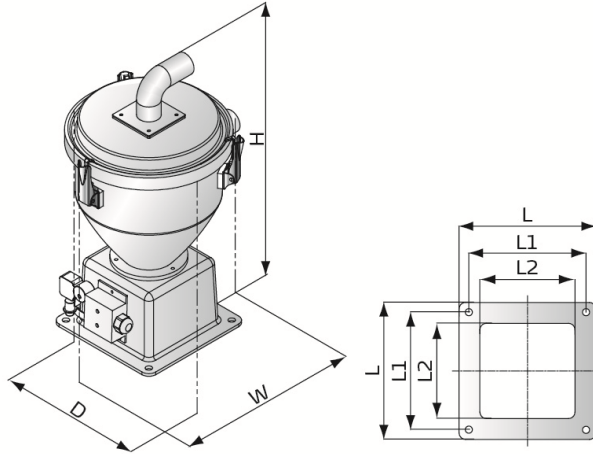

L=210mm

L1=180mm

L2=148mm

SVH

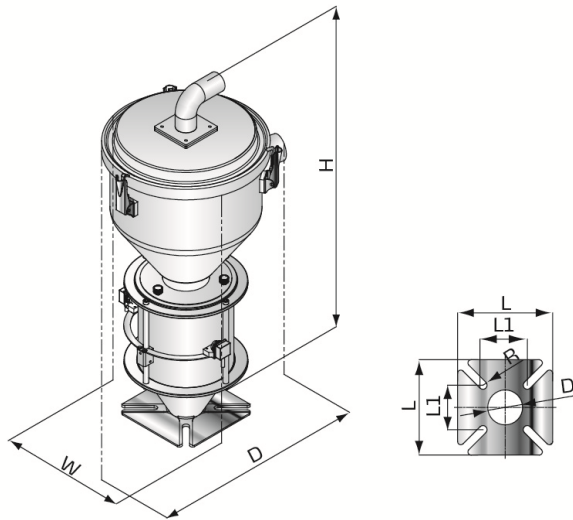

Picture 1-1: External Dimension 1

Models	L(mm)	L1(mm)	D(mm)	R(mm)
SVH-6L	150	70	55	6.5
SVH-12L	180	80	55	6.5

SAL-700G (Main controller)

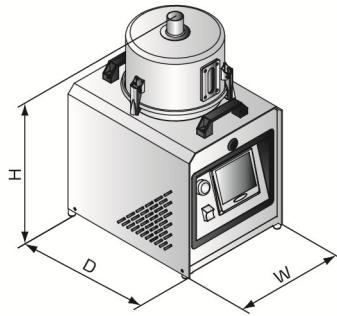

SAL-810G/820G/830G (Main controller)

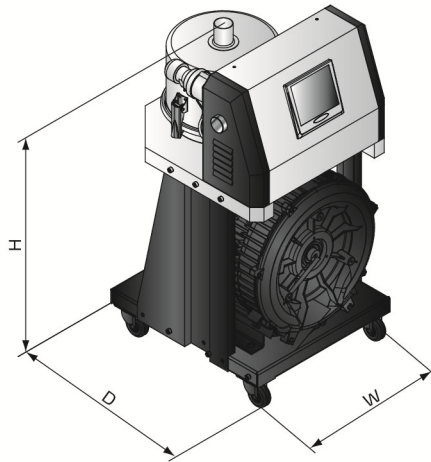

SAL-900G/900G2(Main controller)

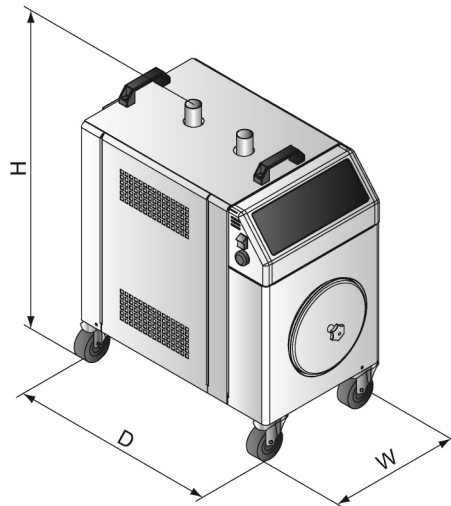

Picture 1-2: External Dimension 2

1.3.2 Specification

Table 1-1: Specification

Main Unit						Hopper Receiver(s)				Conveying Hose Dia. (Inch)	Air Suction Pipe Dia. (Inch)	Conveying Capacity (kg / hr)
Model	Ver.	Motor Type	Motor Power (kW) (50/60Hz)	Dimensions (mm)H×W×D	Weight (kg)	Recommended Model	Hopper Capacity (L)	Dimensions (mm) H×W×D	Weight (kg)			
SAL -700G	E	Carbon brush	1.2(1Φ)	595×300×410	18	SMH-6L	6	460×260×315	6	1.5	1.5	300
						SVH-6L		600×285×305	7			
SAL -810G	A	Induction	0.75(3Φ)	740×400×410	58	SMH-6L	6	460×260×315	6	1.5	1.5	300
						SVH-6L		600×285×305	7			
						SHR-6U		420×285×360	6			
SAL -820G	A	Induction	1.5(3Φ)	740×400×410	65	SMH-12L	12	515×300×350	7	1.5	1.5	500
						SVH-12L		695×300×360	11			
						SHR-12U		470×315×400	7			
SAL -830G	A	Induction	1.85(3Φ)	785×400×410	68	SMH-24L	24	720×325×375	9	2	2	700
						SVH-24L		1120×360×375	13			
						SHR-24U		690×315×400	9			
SAL -900G	C	Induction	0.75(3Φ)	670×390×740	50	1×SMH-6L	6	460×260×315	6	1.5	1.5	500
						1×SVH-6L		600×285×305	7			
						2×SMH-6L		460×260×315	11			
						2×SVH-6L		600×285×305	7			
SAL -900G2	C	Induction	1.5(3Φ)	670×390×740	57	1×SMH-12L	12	515×300×350	7	1.5	1.5	700
						1×SVH-12L		695×300×360	11			
						2×SMH-12L		515×300×350	7			
						2×SVH-12L		695×300×360	11			

Notes: 1) "SVH" stands for photosensor hopper receiver; "SMH" stands for vacuum hopper receiver.

2) Test condition of conveying capacity: Plastic material of bulk density 0.65kg/L, dia. 3~5 mm, vertical conveying height: 4m, horizontal conveying distance: 5m.

3) All SAL-810G/820G/830G hoppers adopt the 4P heavy-duty connector, and all SAL-700G/900G/900G2 hoppers adopt the 3P metal connector.

4) Power supply: 3Φ, 230/400/460/575V, 50/60Hz for all models except SAL-700G (1Φ, 115/230V, 50/60Hz).

1.3.3 Loading Capacity

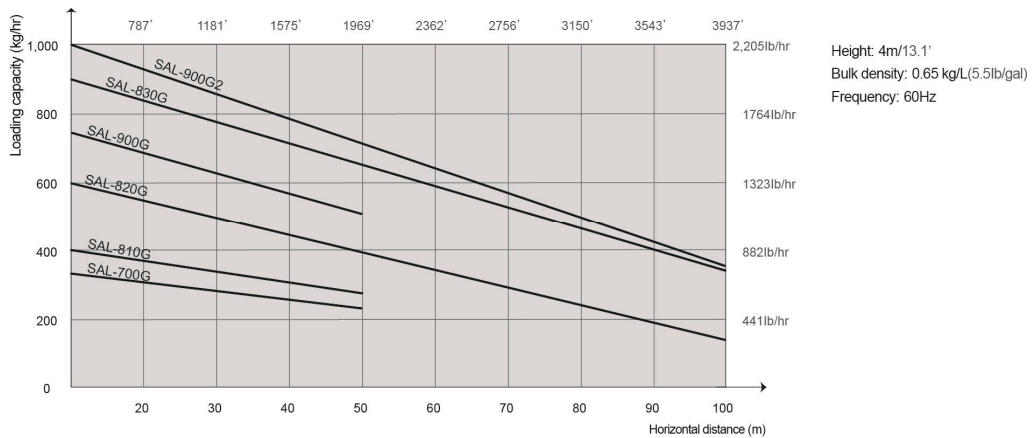

Picture 1-3: Loading Capacity

1.4 Safety Regulations

Please abide by the safety guide when you operate the machine so as to prevent damage of the machine and personal injuries.

1.4.1 Safety Signs and Labels



All electrical components should be installed by qualified electricians.
Turn off main switch and control switch during repair and maintenance.



Warning! High voltage!
This mark is attached on the cover of the control box.



Warning! Be careful!
Be more careful when this mark appears.



Attention!
No need for regular inspection because all the electrical parts in the control unit are fixed tightly!

1.4.2 Signs and Labels

 <p>Please clean the suction filter regularly YPS1423000000</p>	<ol style="list-style-type: none">1. Please clean the suction filter regularly to avoid clogging and ensure proper loading capacity and long life span.2. The one year warranty does not cover the suction filter, please clean the filter carefully.
--	--

2. Structure Characteristics and Working Principle

2.1 Working Principle

SAL-G series are suitable for conveying plastic granules over long distance. Utilizing high efficiency vacuum blower to produce vacuum in material hopper, plastic materials will then be fed into material hopper by air pressure.

2.1.1 SAL-700G/810G/820G/830G Working Principle

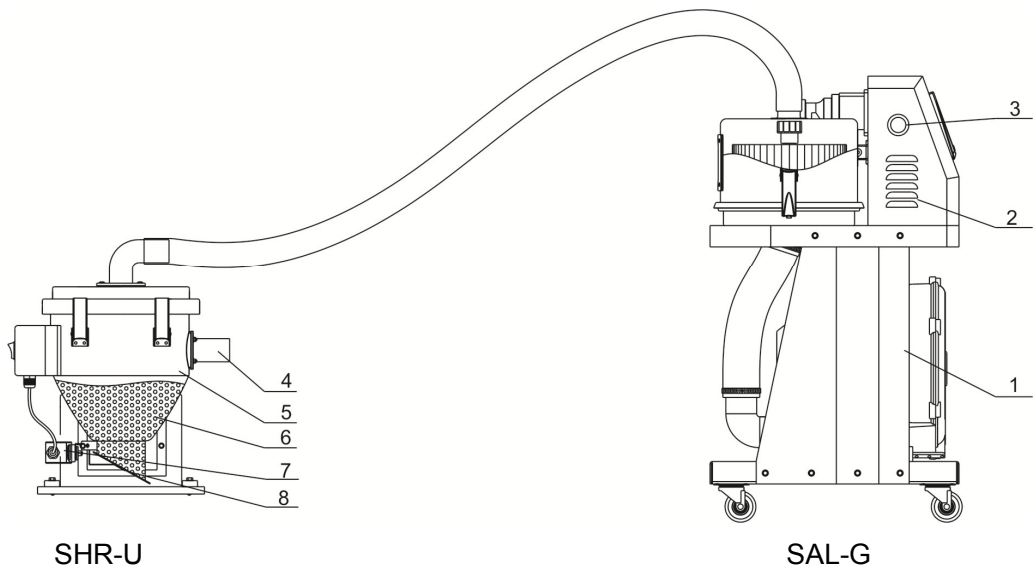

Picture 2-1: Working Principle 1

- | | |
|-------------------------|------------------------|
| 1. High-pressure blower | 2. Control box |
| 3. Buzzer | 4. Material inlet pipe |
| 5. Storage hopper | 6. Materials |
| 7. Reed switch | 8. Discharging plate |

Turn on the machine, the high pressure blower(1)starts work, it makes storage hopper (5) generate the vacuum. Discharging plate(8) closed, materials in silo get into the storage hopper(5) through material inlet pipe(4) by air pressure. When the loader finishes the work, high pressure blower(1) stop working, materials (6) will drop off due to gravity. When the reed switch (7) detects there's no material, high pressure blower (1) will start working again. When the loader can't suck the material or material shortage, the buzzer(3) on control box(2) will alarm.

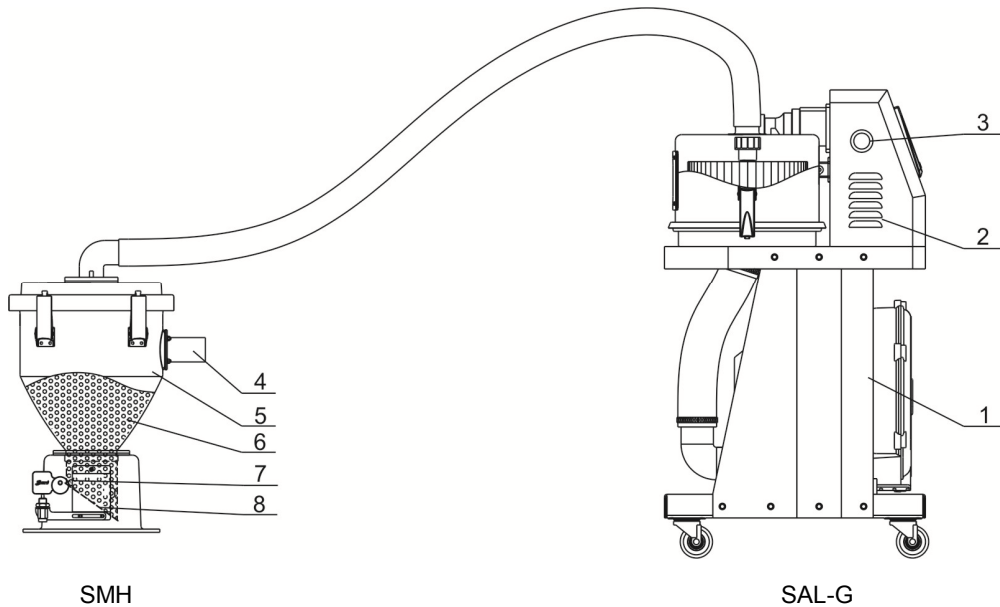

Picture 2-2: Working Principle 2

- | | |
|-------------------------|------------------------|
| 1. High-pressure blower | 2. Control box |
| 3. Buzzer | 4. Material inlet pipe |
| 5. Storage hopper | 6. Materials |
| 7. Micro switch | 8. Discharging plate |

When the machine is on, the high pressure blower(1) starts to work, and it makes storage hopper(5) generate the vacuum. The discharging plate(8) is closed, and then materials in silo get into the storage hopper(5) through material inlet pipe(4) owing to air pressure. When the loader finishes its work, high pressure blower(1) stops working, and materials(6) will drop off because of gravity. When the micro switch(7) detects there's no material, high pressure blower(1) will start to work again. When the loader can't suck the material or there is material shortage, buzzer(3) on the control box(2) will sound an alarm.

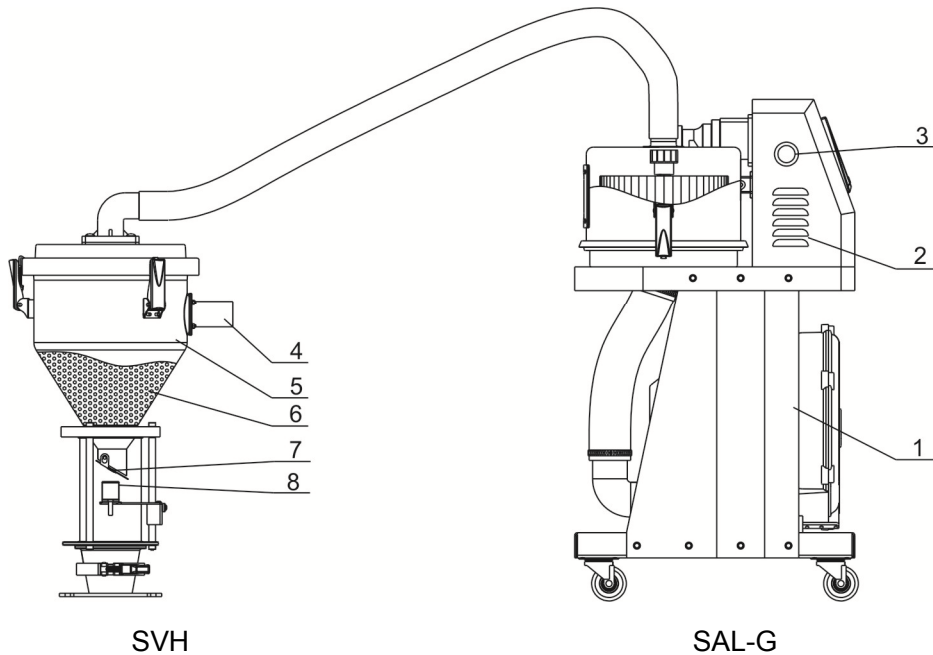

Picture 2-3: Working Principle 3

- | | |
|-------------------------|-------------------------|
| 1. High-pressure blower | 2. Control box |
| 3. Buzzer | 4. Material inlet pipe |
| 5. Storage hopper | 6. Materials |
| 7. Discharging plate | 8. Photoelectric switch |

When the machine is on, the high pressure blower(1) starts to work, and it makes storage hopper(5) generate the vacuum. The discharging plate(7) is closed, and then materials in silo get into the storage hopper(5) through material inlet pipe(4) owing to air pressure. When the loader finishes its work, high pressure blower(1) stops working, and materials(6) will drop off because of gravity. When the photoelectric switch(8) detects there's no material, high pressure blower(1) will start to work again. When the loader can't suck the material or there is material shortage, buzzer(3) on the control box(2) will sound an alarm.

2.1.2 SAL-900G/900G2 Working Principle

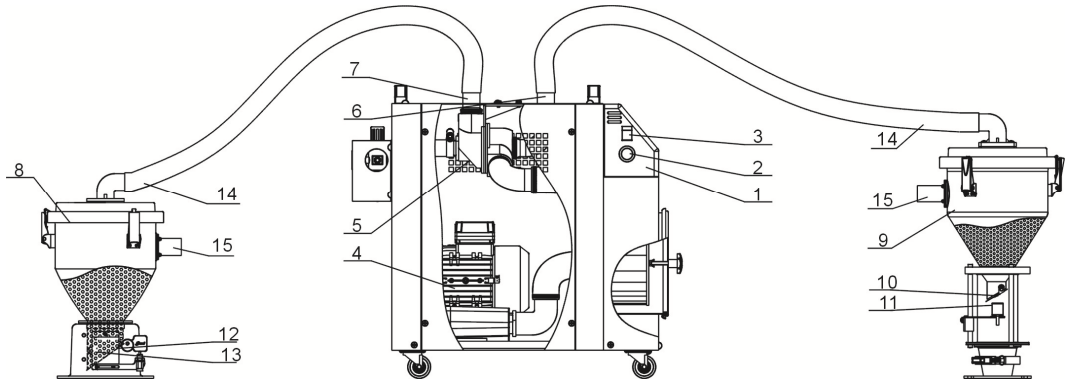

Picture 2-4: Working Principle (SAL-900G/900G2)

- | | |
|-------------------------|-------------------------|
| 1. Control box | 2. Buzzer |
| 3. Alternative switch | 4. High-pressure blower |
| 5. Three way valve | 6. Air suction inlet 1 |
| 7. Air suction inlet 2 | 8. Storage hopper 1 |
| 9. Storage hopper 2 | 10. Discharging plate1 |
| 11. Photosensor | 12. Discharging plate2 |
| 13. Microswitch | 14. Hopper suction pipe |
| 15. Material inlet pipe | |

Turn on the alternative switch (3), via the operation panel to set the suction time of the storage hopper 1 (8) and storage hopper 2 (9), then press the start button and the high pressure blower (4) starts work. The air suction inlet 1 (6) of three way valve (5) opens and the air suction inlet 2 (7) closes, discharging plate (10) closes, and then storage hopper 1 (8) starts suctioning material, after material suction finishes, the high pressure blower (4) stops. Because of deadweight, materials in storage hopper 1 (8) drops down. When the microswitch (13) detects that there is no material in the storage hopper 2 (9), blower (4) works again. And solenoid valve works, three way valve (5) controlled air suction inlet 2 (7) opens, and discharging plate 2 (12) closes, storage hopper 2 (9) begins suctioning material, when finished, if photosensor (11) detect that there is no material in storage hopper 1 (8), via the solenoid valve alternative, the high pressure blower (4) start working again. The machine works according to this cycle. The buzzer (2) on control box (1) will give an alarm when material can not be sucked or there is no material.

2.2 Options

- Cyclone dust collector

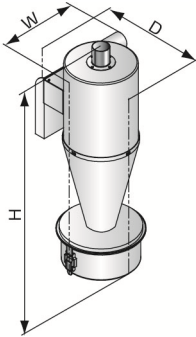

It is suggested to opt cyclone dust collector to reduce cleaning times of filter when regrind material occupies over 30% of total raw material.

Model	Capacity (H×W×D)	Pipe diameter (inch)
ACF-1	550×220×235	1.5
ACF-2	550×220×235	2.0

- For SHR,SCH-6U/12U/24U and SICH-6U/12U/24U are optional (Temperature reduction is below 30 °C within 30min).
- SPV-U (control box is included) is optional.
- Proportional valve SPV-U (control cabinet is optional) is available,which is adopted to mix virgin and regrind materials,as well as instantly recycle regrind material.
- For folished hopper inside ones,add “P” at the end of model code.

3. Installation Layout

3.1 SAL-700G/810G/820G/830G

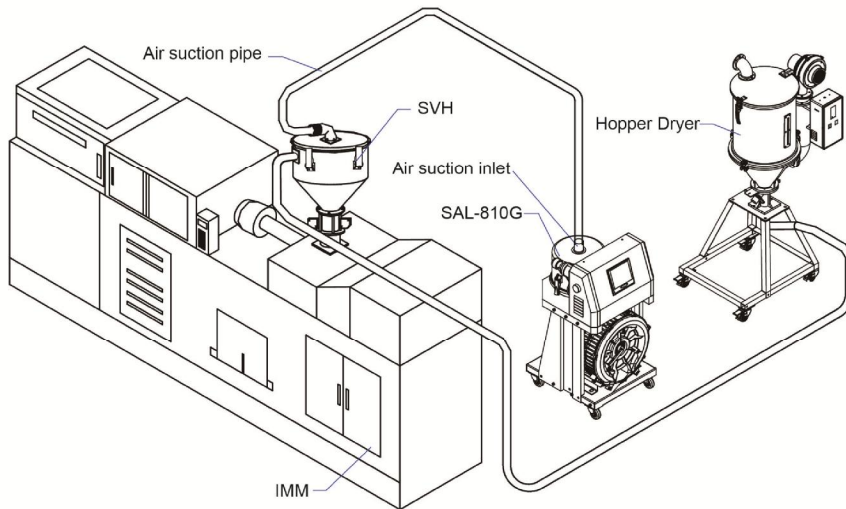

Picture 3-1: Installation Layout 1

Notes for Installation and Positioning:

- 1) Machine just can be mounted in vertical position. Make sure there's no pipe, fixed structure or other objects above the installing location and around the machine which may block machine's installation, hit objects or injure human person.
- 2) For easy maintenance, it's suggested to leave 1m space around the machine.
- 3) Machine should be placed on water-level surface. If it needs to be mounted on a higher surface (e.g. the scaffold or the interlayer), should ensure its structure and size could bear the weight and size of the machine.

Installation:

- 1) Place the SAL-700G/810G/820G/830G machine at a proper position on the ground, connect the three phase power cord and the earth.
- 2) Install the material hopper on the top of the hopper dryer and the sensor hopper onto the plastic injection machine. Connect the signal cord to the machine SAL-700G/810G/820G/830G.
- 3) Use the steel wire soft hose, connect the air inlets of the sensor hopper to the current air inlets of SAL-700G/810G/820G/830G, then connect the material inlets of storage tank to the vacuum hopper.

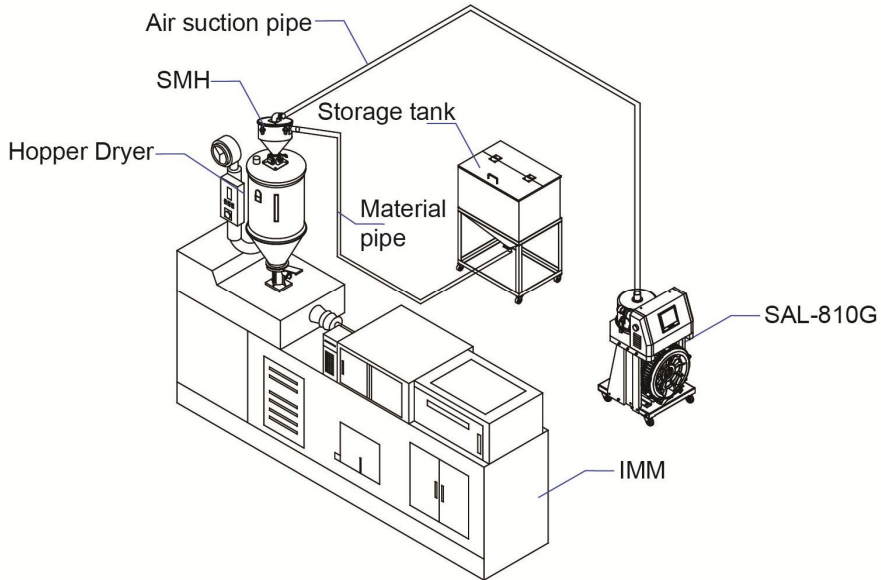

Picture 3-2: Installation Layout 2

Installation:

- 1) Place the machine SAL-700G/810G/820G/830G at a proper position on the ground, connect the three phase power cord and the earth.
- 2) Install the material hopper on the top of hopper dryer, and connect the signal to the machine SAL-700G/810G/820G/830G.
- 3) Use the steel wire hose, connect the air inlets of SMH to corresponding air inlets of SAL-700G/810G/820G/830G. Then connect the other air inlets of SMH to the air inlets storage tank with hose .

3.2 SAL-900G/900G2

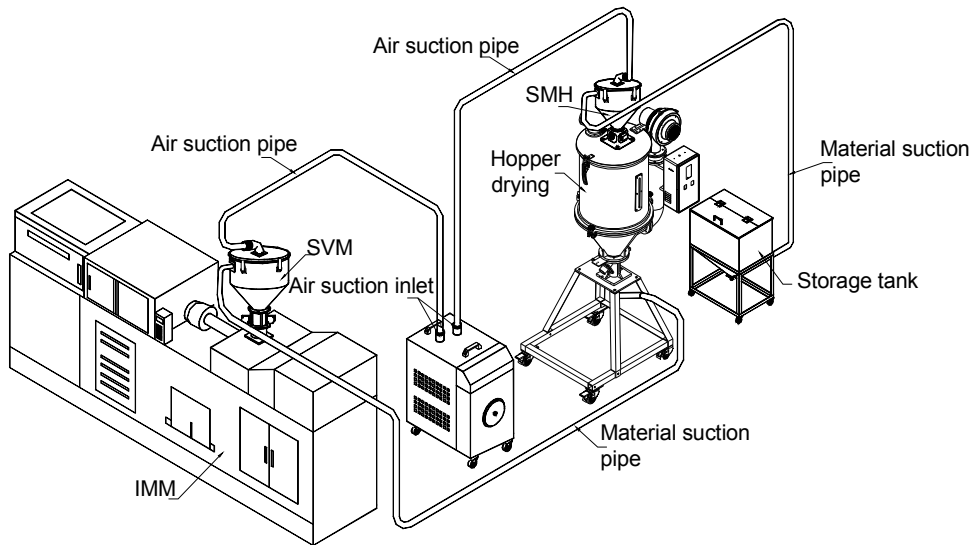

Picture 3-3: Installation Layout 1

Notes for Installation and Positioning:

- 1) Machine just can be mounted in vertical position. Make sure there's no pipe, fixed structure or other objects above the installing location and around the machine which may block machine's installation, hit objects or injure human person.
- 2) For easy maintenance, it's suggested to leave 1m space around the machine.
- 3) Machine should be placed on water-level surface. If it needs to be mounted on a higher surface (e.g. the scaffold or the interlayer), should ensure its structure and size could bear the weight and size of the machine.

Installation:

- 1) Place the SAL-900G/900G2 machine at a proper position on the ground, connect the three phase power cord and the earth.
- 2) Install the material hopper on the top of the hopper dryer and the sensor hopper onto the plastic injection machine. Connect the signal cord to the machine SAL-900G/900G2 .
- 3) Use the steel wire soft hose, connect the air inlets of the sensor hopper and the vacuum hopper to the current air inlets of SAL-900G/900G2, then connect the material inlets of storage tank to the vacuum hopper. And

connect the material inlets of sensor hopper to the hopper dryer.

*Optional shut-off valve. It makes no material remain in the suction material hose, and avoid remaining material be moisture regain. Its working principle: The shut-off valve is linked-do with the sensor hopper, when the hopper is working, the shut-off valve can be open, and it lasts for some time (adjusted time), then it can be closed. In this period, the auto-load goes on working for suction, and the materials remain in the material hose A will be sucked into sensor hopper completely.

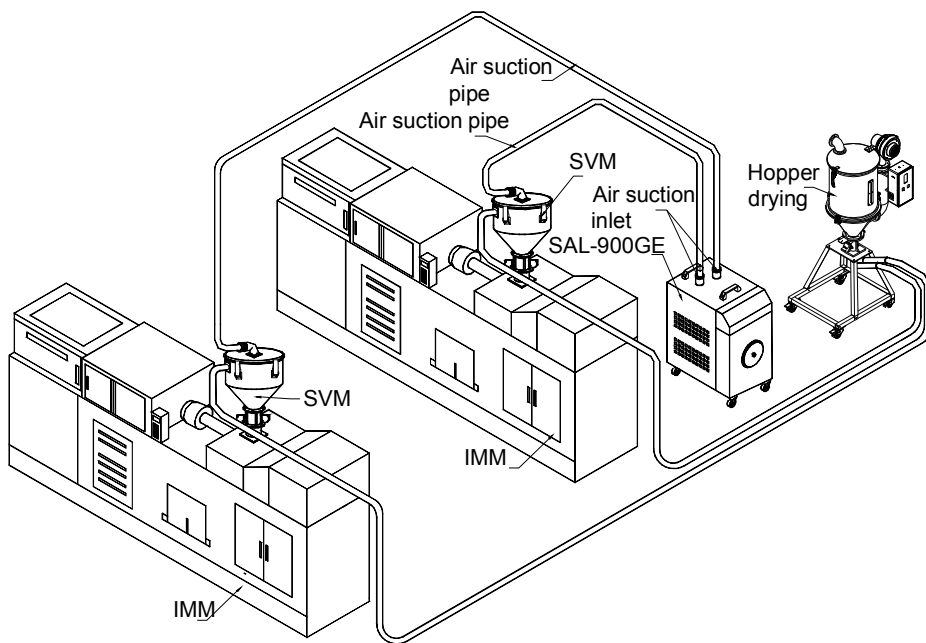

Picture 3-4: Installation Layout 2

Installation:

- 1) Place the SAL-900G/900G2 machine at a proper position on the ground, connect the three phase power cord and the earth.
- 2) Install the photosensor hopper receiver (SVH) on plastic injection machine. Connect the signal cord to the machine SAL-900G/900G2 .
- 3) Use the steel wire hose to connect the air suction inlets of photosensor hopper receiver (SVH) to the air inlet of SAL-900G/900G2. Then connect the material suction inlets of hopper dryer to material suction inlets of photosensor hopper receiver (SVH).

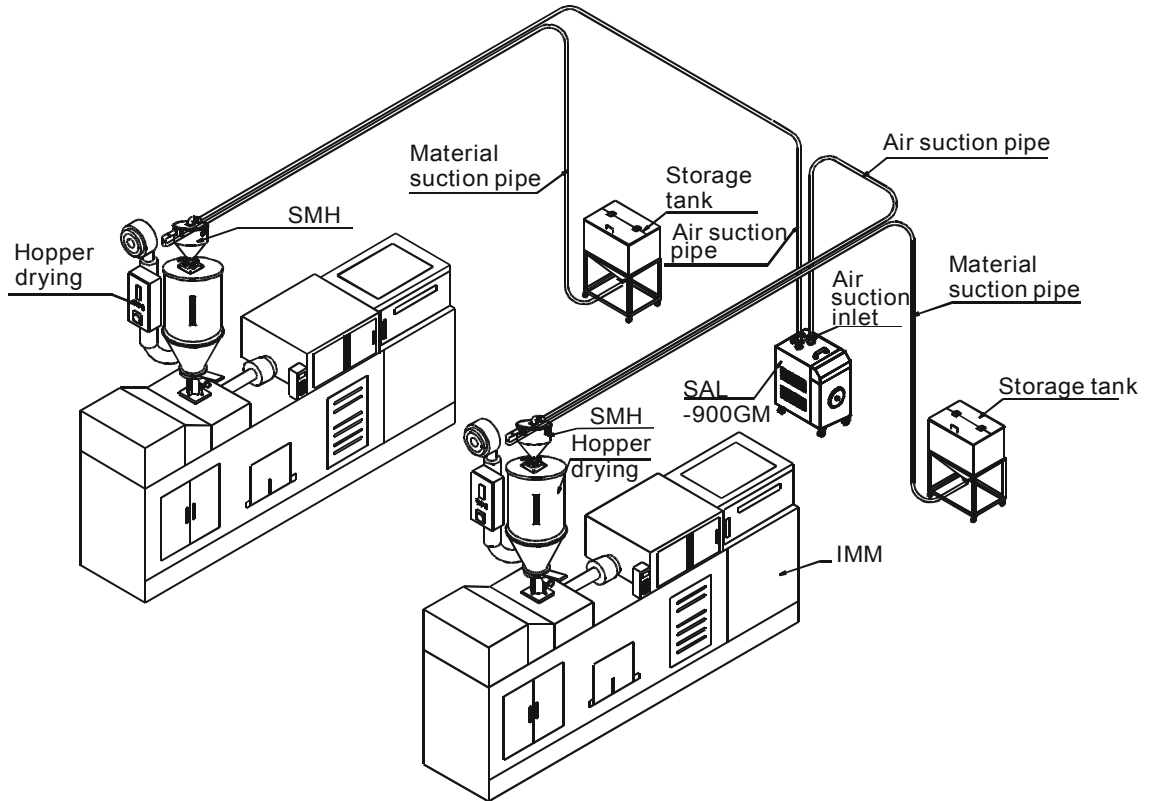

Picture 3-5: Installation Layout 3

Installation:

- 1) Place the SAL-900G/900G2 machine at a proper position on the ground, connect the three phase power cord and the earth.
- 2) Install the material hopper(SMH) on the hopper dryer. Connect the signal cord to the machine SAL-900G/900G2.
- 3) Use the steel wire soft hose, connect the air suction inlet of vacuum hopper (SMH) to corresponding air inlets of the SAL-900G/900G2. Then connect the material inlets of vacuum hopper to the storage hopper (SMH).

3.3 Installation of Vacuum Hopper Receiver SMH Optional Storage Collective Hopper SCH-6L

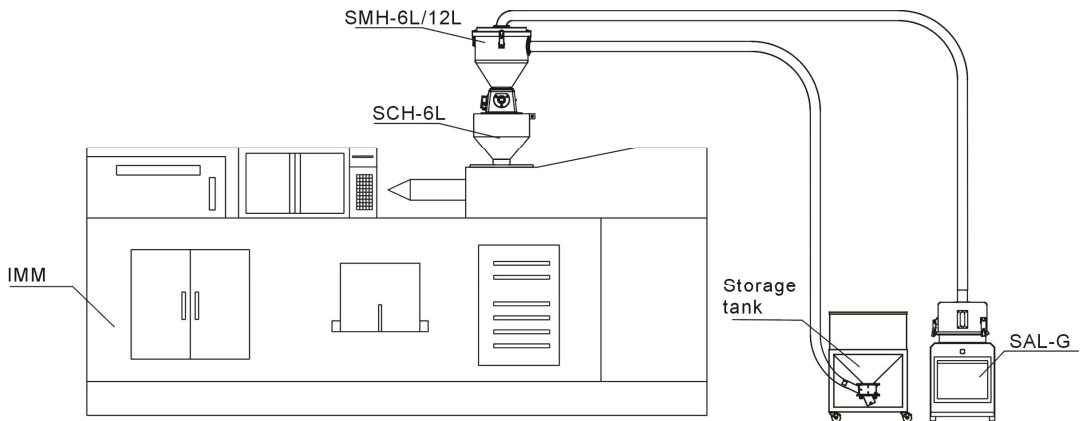

Picture 3-6: Optional SCH-6L Installation Layout

SMH-6L/12L vacuum hopper can option with collection hopper SCH-6H for direct mounting at material inlet of the molding machine.

Installation:

- 1) Mount the SCH-6L at material inlet of molding machine, point to the holes and lock the screws.
- 2) Put the SMH-6L/12L on the SCH-6H, point to the holes and lock the screws, then connect the signal wire to the hopper loader of SAL-G.
- 3) Connect the air inlet of vacuum hopper with steel wire hose separately to corresponding air inlet of SAL-G. Connect the material inlet of storage silo to the material inlet of vacuum hopper.

3.4 Installation of SAL-G Optional Proportional Valve

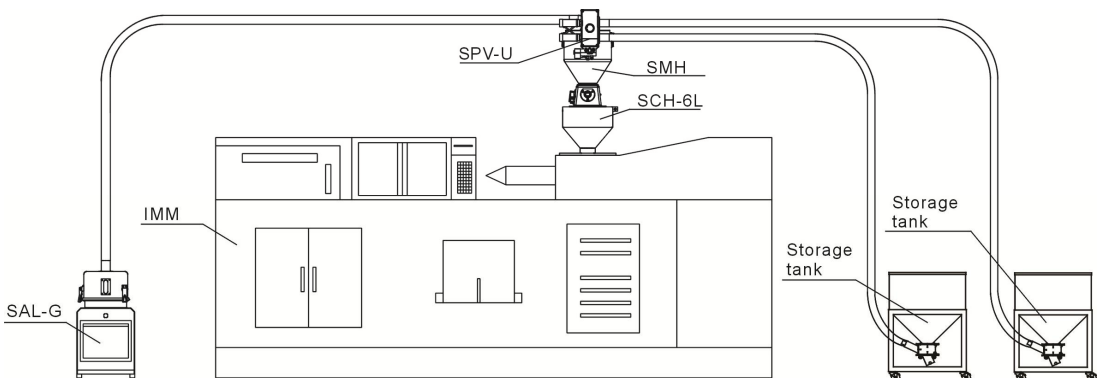

Picture 3-7: Optional SPV-U Installation Layout

Optional proportional valve SPV-U can realize two kinds of materials mixing.

Installation:

- 1) Mount the SPV-U at material inlet of SMH(SVH) lock up and fix the screws.
- 2) Put the SMH on SCH-6L or put the SVH at the material inlet of molding machine. Point to the holes and lock up the screws, then connect the signal wire to the hopper loader of SAL-G.
- 3) Connect the air inlet of vacuum hopper with steel wire hose separately to corresponding air inlet of SAL-G. Connect the material inlet of storage silo to the material inlet of vacuum hopper.

3.5 Installation of SAL-G Optional Cyclone Dust Separator

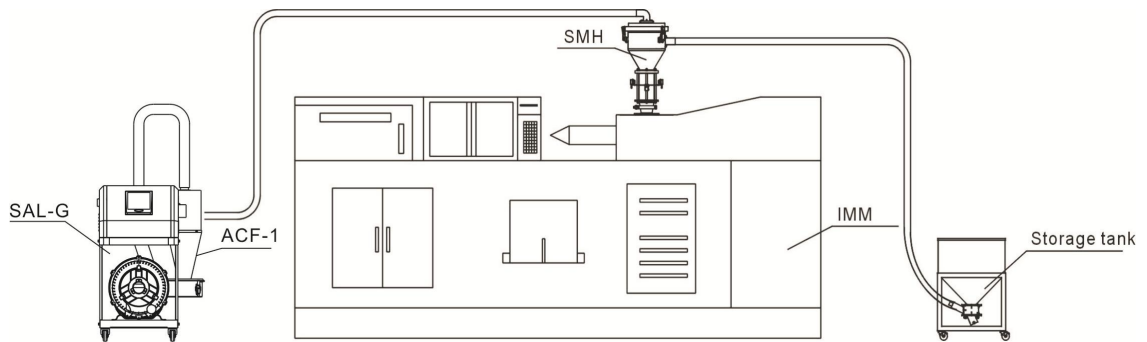

Picture 3-8: Optional ACF-1 Installation Layout

When conveying plastics contain dusts in high proportion, optional dust cyclone separator is recommended to reduce the purging times of main machine filter.

Installation:

- 1) Mount the ACF-1 on coverplate of SAL-G and lock up the screws(There's two holes on coverplate of SAL-G main machine for installation);
- 2) Connect the air inlet of SAL-G main machine with steel wire hose to air outlet of ACF-1.
- 3) Connect the air inlet of ACF-1 with steel wire hose to air inlet of the hopper;
- 4) Connect one end of steel wire hose to hopper material inlet, and connect to the suction inlet of storage tank.

4. Operation

4.1 SAL-700G/810G/820G/830G

4.1.1 Panel Description

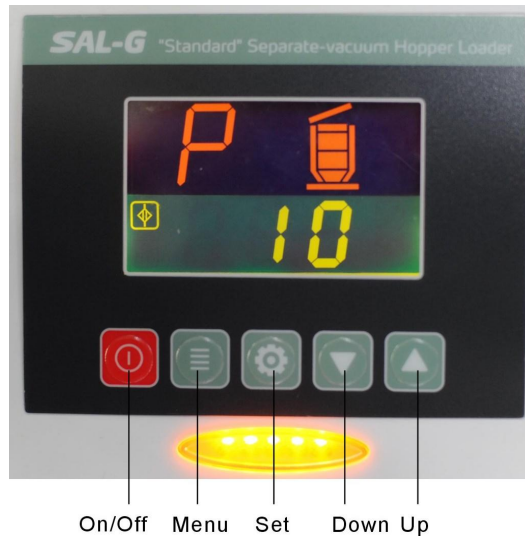

Picture 4-1: Panel

Lamp Description:



Level sensor signal state



Full load indicator



Overload alarm



Reverse, purging

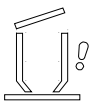

Shortage alarm



Communication indicator

Machine in stand by, upper panel shows “P”, lower digital displays suction time. Machine in suction, upper panel shows “D”, lower suction time starts count down, the corresponding lamp turns on.

After suction, awaits motor stop time, upper panel shows “N”, lower stop time starts count down.

Machine reverse purging or cleaing, upper panel shows “R”, lower reverse-run time and cleaning times start count down.

Timer setting, upper panel shows “Fx” mode, lower digital is set value of the parameter.

4.1.2 Setting Description

Select the mode

Press Menu key for 3 seconds, set mode C1, C2, C3, C4.

(Please refer to 14.3.2)

Pin 1, 2 of J1 short circuit can select C1, C2, C4 mode, Pin 2,3 of J1 short circuit can select C1,C3,C4 mode)

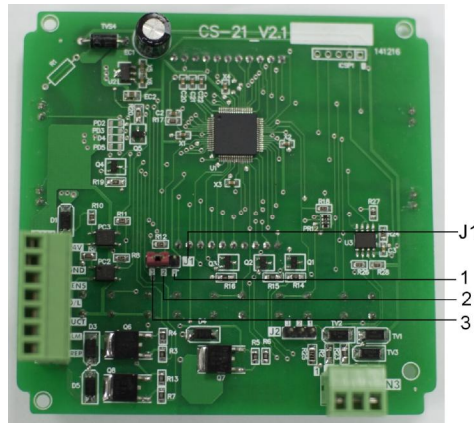

Parameter Setting

Press **Menu key**, and enter parameter setting.

Step 1, Press “Up” and “Down” to select parameter of F1~F8, press “Set” to enter setting

Step 2, press “Up” and “Down” to adjust the parameters, press “Set” for confirmation and return to up page.

Code	Status	Default Value	Adjusting Range	Mode
F1	Suction time setting	10 Secs.	1~99 Secs.	C1,C2,C3,C4
F2	Necessary spray washing times every several times for operation	3 Times	1~10 Times	C2
F3	Necessary cleaing times for reverse running every several times of operation	3 Times	1~10 Times	C3
F4	Motor reverse running time	10 Secs.	5~30 Secs.	C3
F5	Alarm detecting time	20 Secs.	10~40 Secs.	C1,C2,C3,C4
F6	Awaits motor to stop time	30 Secs.	30~99 Secs.	C3
F7	Purge times	2 Times	1~5 Times	C2
F8	Suction awaits time	0	0~99 Times	C1,C2,C3,C4

At stand-by mode, press “Down” and “Up” for 3 secs. and enter manual cleaning mode; Hold on to press “Down” and “Up”, it will process cleaing all the time till these two keys loosen.

When the circuit board has communication function, there are two parameters as below for selection, the operation: after select the F08, use “Up” and “Down” to select suitable parameters.

Code	Status	Default Value	Adjusting Range	Mode
F9	Communication baud rate	1(9600)	0—19200, 1—9600,2=4800	C1,C2,C3,C4
F10	Communication address	1	1~99	C1,C2,C3,C4
F11	Odd-even verification	0	0— no verification 1— odd verification 2— even verification	C1,C2,C3,C4

Table 4-1: CS-21 Mosbus Parameter

No.	Code	Parameters	Min Para.	Max Para.	Default	Unit
0x00	R	bit 0 shutdown	0 start up	1 shutdown		
		bit 1 stand by		1 stand by		
		bit 2 suction		1 suction		
		bit 3 detect shortage time after suction		1 detecting		
		bit 4 Reverse purging		1 purging		
		bit 5 Reverse running return time		1 calculating		
		bit 6 Overload alarm		1 alarming		
		bit 7 Shortage alarm		1 alarming		
0x01	R	Real-time information				
0x02	R/W	Running mode	1	4	1	
0x03	R/W	Suction time	5	99	10	s
0x04	R/W	Several times running needs cleaing	1	10	3	times
0x05	R/W	Several times running needs reverse	1	10	3	times
0x06	R/W	Reverse time	5	30	10	s
0x07	R/W	Time start to alarm after material shortage	10	40	20	s
0x08	R/W	Reverse return time	30	99	30	s
0x09	R/W	C2 cleaing times	1	5	2	times
0x0a	R/W	Suction awaits time	0	99	0	mins
0x0b	R	0x02 actual running times				times
0x0c	R	0x03 actual running times				times
0x0d	R	bit 0 shortage input signal	0 overload	1 shortage		
		bit 1 overload input signal	0 no load	1 overload		
		bit 2, bit3 reserve				
		bit 4 suction output	0 no output	1 output		
		bit 5 purging output	0 no output	1 output		
		bit 6 alarm output	0 no output	1 output		
		bit 7 shortage alarm				
0x0e	R	bit 0 shutdown	0 start up	1 shutdown		
		bit 1 stand by		1 stand by		
		bit 2 suction		1 suction		
		bit 3 detect shortage time after suction		1 Detecting		
		bit 4 reverse purging		1 purging		
		bit 5 reverse running return time		1 calculating		
		bit 6 overload alarm		1 alarming		
		bit 7 shortage alarm		1 alarming		
0x0f	W	shutdown signal	0 start up	1 shutdown		

Communication setting (baud rate, no parity check, 8bit 1 stop bit)

Pin 2, 3 of J2 short circuit, communication set for terminal resistance.

4.2 SAL-900G/900G2 Operation

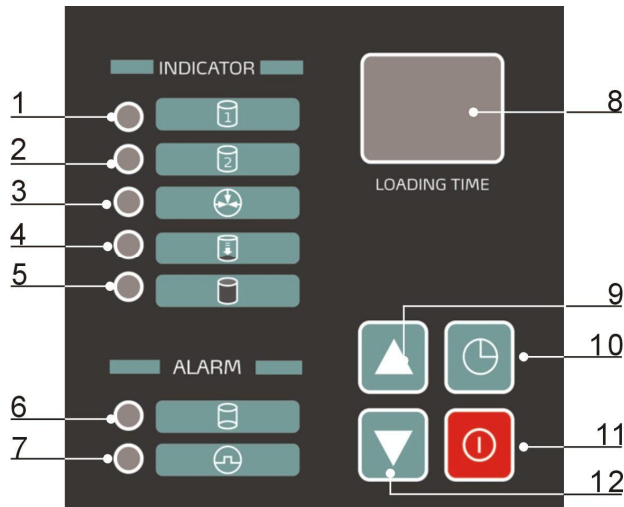











Picture 4-2: Control Panel(SAL-900G/900G2)

Table 4-2: Control Panel Description (SAL-900G/900G2)



No.	Description	Function
1	Hopper 1	Hopper 1 is at operation/setting state
2	Hopper 2	Hopper 2 is at operation/setting state
3	Shut off valve	Shut off valve is at open/closed state
4	Suction	Machine is at suction state
5	Full of material	Hopper is full of material
6	Shortage alarm	Material shortage alarm
7	Overload alarm	Motor at alarm state
8	Time display	Display time/parameter
9	Increase key	Parameter increase
10	Set key	Enter parameter setting
11	Start/stop key	Machine is at start/stop control
12	Decrease key	Parameter decrease

Operation:

1. Connect the power supply, "--" is displayed on LED, then enter to set loading time.
2. Press key "🕒", the lamp of LOAD1 turns red. Then press key "⬆️⬇️" to set the loading time of LOAD1.

3. Press the key "" again, the lamp of LOAD2 turns red. Then press the key "" to set the loading time of LOAD2.
4. Press the key "" once more, the lamp of GATE turns red. Then press the key "" to set the loading time of shut-off valve.
5. After setting, press key "" to confirm.
6. Press once the key "", the LOAD1 starts auto-working. Press twice the key "", both the LOAD1 and LOAD2 start auto-working. Press three times the key "", only the LOAD2 starts auto-working. Then press four times the key "", the machine stops.

Notes:

1. When running out of material, the operation will auto-stop and sound the alarm. Press  button for closing the alarm sound and stoppage. After refilling the material, Press the  button to start the operation.
2. Check suction filter periodically and clean filter screen if necessary.

5. Troubleshooting

Fault	Possible reasons	Solutions
When shortage lasts long, and suction blower don't run.	The main switch and control switch don't open or the above two don't connect well.	Close the main switch and control switch and check their connecting.
	The microswitch on hopper don't connect well .	Adjust or replace.
	The signal wire is break off.	Re-connect.
The suction blower still running when the hopper is full.	The touch point is conglutinated	Repair or replace.
After several times of loading the material hopper still empty or the material shortage alarms.	The storage tank is empty.	Add the material
	The pipe is air leak.	Lock tightly and replace the vacuuming pipe.
	The filter is blocked.	Clean the filter.
The motor can't run.	Short-phase or motor was burnt out.	Check and replace.
The fuse always burnt out after start-up.	Short circuit or connect the ground.	Check the circuit.
Motor overload alarms	The filter is blocked.	Clean the filter and reset the overload relay.
	One of three phase is lacking.	Check the circuit and reset the overload relay.kkk
Poor material liquidityin the pipe	Over or lack of air quantity	Adjust air inlet location of the suction box. Avoid small bending of the elbow.

6. Maintenance

6.1 Hopper Cleaning

SMH Cleaning: In order to avoid air-blocking and to get smooth conveying.

Clean the filter screen inside of material hopper. Unlock the snap hook on the hopper, remove the hopper cover and take out the filter screen, then clean it. Clean the filter periodically or when the suction force is reduced.

SVH Cleaning:

1. Clean the filter screen, in order to avoid air-blocking and to get smooth conveying. Clean the filter screen inside of material hopper. Unlock the snap hook on the hopper, remove the cover and take out the filter, then clean it. Clean periodically or when the suction force is reduced.
2. Clean the glass pipe, when the dust accreted on the tube. Clean the dust in time for machine normal working.

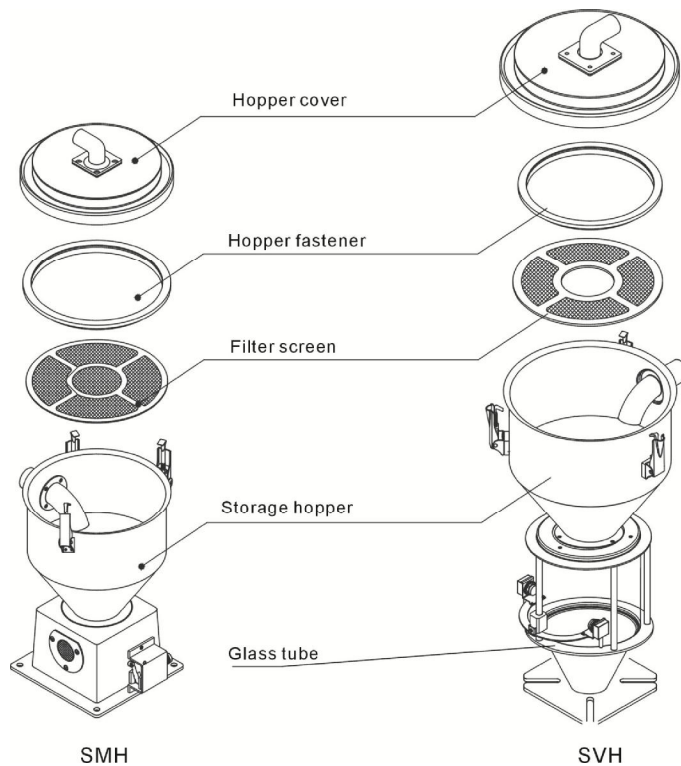

Picture 6-1: Hopper Cleaning

6.2 Main Body Cleaning

When machine in use, clean the filter periodically or when the suction force is reduced. Take out the filter from the main body, clean the dust accreted on it to ensure good ventilation of the air and to enhance loading capacity.

Filter Inspection and Storage Hopper Cleaning

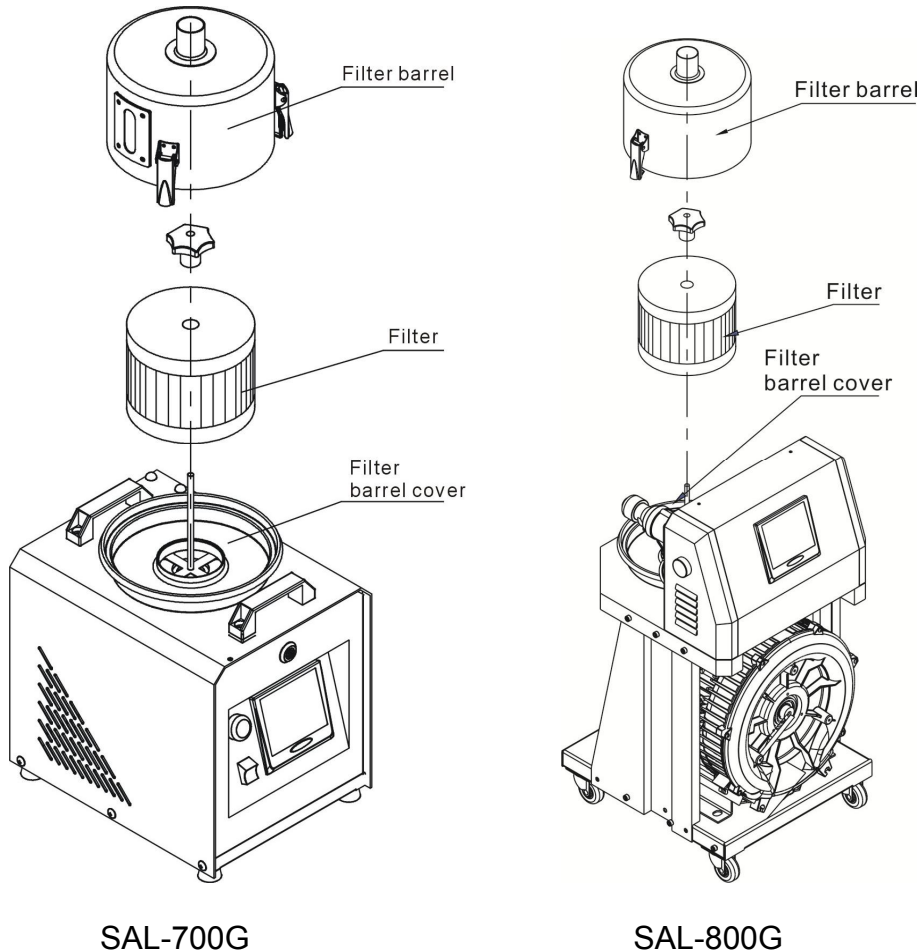

1. Loosen the snap hook, take out the filter barrel and the filter; blow off the dust with a high-pressure air gun from the inside to outside; take down the filter barrel cover and remove the dust in it.
2. Clean the filter. Period: daily

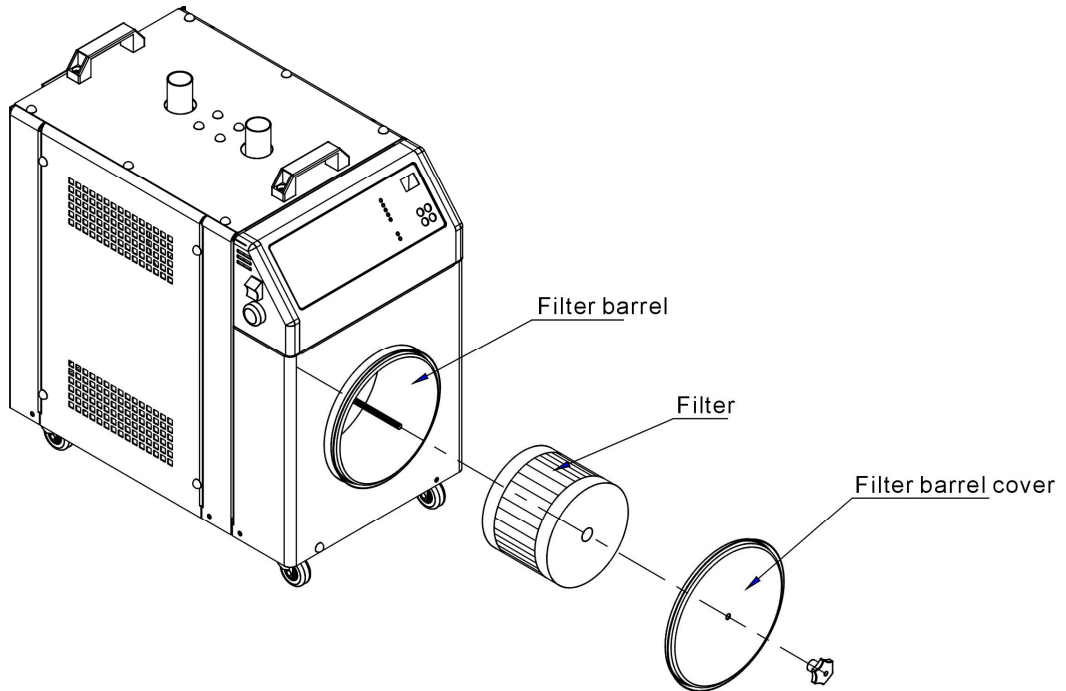

SAL-900G

1. Open the filter barrel cover and take out the filter; blow off the dust with a high pressure air gun from the inside to outside; take down the filter barrel lid and remove the dust in it.
2. Clean the filter. Period: daily