

# **SAL-UG**

## **Separate-vacuum Hopper Loader**

Date: Dec, 2017

Version: Ver.B (English)





## Contents

<b>1. General Description .....</b>	<b>7</b>
1.1 Coding Principle .....	8
1.2 Feature.....	8
1.3 Technical Specifications.....	10
1.3.1 Dimensions.....	10
1.3.2 Specifications .....	11
1.3.3 Loading capacity.....	12
1.4 Safety Regulations .....	12
1.4.1 Safety Signs and Labels.....	12
1.4.2 Signs and Labels .....	13
1.5 Exemption Clause .....	13
<b>2. Structure Characteristics and Working Principle .....</b>	<b>14</b>
2.1 Main Functions.....	14
2.1.1 Working Principle.....	14
2.2 Description of Electrical Components .....	16
2.2.1 Opposite-type Photoelectric Switch .....	16
2.2.2 Magnetic Proximity Switch.....	16
2.3 Optional Accessories .....	17
2.3.1 Air Accumulator .....	17
2.3.1.1 Function of air Accumulator.....	17
2.3.1.2 Specification of air Accumulator .....	17
2.3.2 Cyclone dust separator.....	17
2.3.2.1 Cyclone Dust Separator Specifications .....	18
2.3.3 Buzzar .....	18
<b>3. Installation and Debugging.....</b>	<b>19</b>
3.1 Install the Machine on the Dryer.....	19
3.1.1 Installation Elements .....	19
3.1.2 Installation Steps .....	19
3.1.3 Power Supply .....	20
<b>4. Application and Operation.....</b>	<b>21</b>

4.1	Start / Stop of the Machine.....	21
4.2	Keys on the Control Panel .....	21
4.3	Parameter Setting .....	21
4.3.1	Enter Basic Setting Mode .....	21
4.3.2	Modify a Parameter .....	22
4.3.3	Finish Parameter Setting .....	22
4.3.4	Basic Parameter List .....	22
4.4	Process Setting.....	23
4.4.1	Enter into process setting mode .....	23
4.4.2	Modify a Parameter .....	23
4.4.3	Finish Parameter Setting .....	23
4.4.4	Process Parameter List .....	23
4.5	Special Process Setting .....	24
4.5.1	Enter into Special Step Setting Mode .....	24
4.5.2	Modify a Parameter .....	24
4.5.3	Finish Parameter Setting .....	25
4.5.4	Parameter List of Special Process Setting.....	25
4.6	Explanation of Operation Procedures .....	26
4.6.1	Operation Procedures .....	26
4.6.2	Alarms .....	27
<b>5.</b>	<b>Trouble-shooting .....</b>	<b>29</b>
<b>6.</b>	<b>Maintenance and Repair .....</b>	<b>30</b>
6.1	Material Hopper.....	30
6.2	Main Body .....	31
6.3	Glass Tube.....	31
6.4	Reed Switch, Photoelectric Switch.....	32
6.5	Weekly Checking .....	32
6.6	Monthly Checking.....	32
6.7	Maintenance Schedule.....	33
6.7.1	About the Machine.....	33
6.7.2	Installation & Inspection.....	33
6.7.3	Daily Checking.....	33
6.7.4	Weekly Checking.....	33
6.7.5	Monthly Checking .....	33

## Form Index

Chart 1-1: Hopper Base Installation Size Chart .....	11
Chart 1-2: Specifications.....	11
Chart 2-1: Specification of Cyclone Dust Separator.....	18

## Picture Index

Picture 1-1: SAL-UG Dimensions .....	10
Picture 1-2: Dimensions of Material Hopper .....	10
Picture 1-3: Loading Capacity.....	12
Picture 2-1: Working Principle .....	14
Picture 2-2: Opposite-type Photoelectric Switch .....	16
Picture 2-3: Magnetic Proximity Switch.....	16
Picture 2-4: Air Accumulator .....	17
Picture 2-5: Cyclone Dust Separator .....	17
Picture 2-6: Dimension of Cyclone Dust Separator .....	18
Picture 2-7: Buzzer .....	18
Picture 3-1: Installation Elements .....	19
Picture 4-1: Keys on the Control Panel.....	21



## 1. General Description



Read this manual carefully before operation to prevent damage of the machine or personal injuries.

SAL-UG series separate-vacuum hopper loader are based on the established design and now feature more attractive appearance, better performance, and improved ease of operation. The whole range comprises of seven models equipped with vacuum blower from 1 to 15 HP. Economy models can be offered on request.



Model: SAL-5HP-UG&SHR-24U

## 1.1 Coding Principle

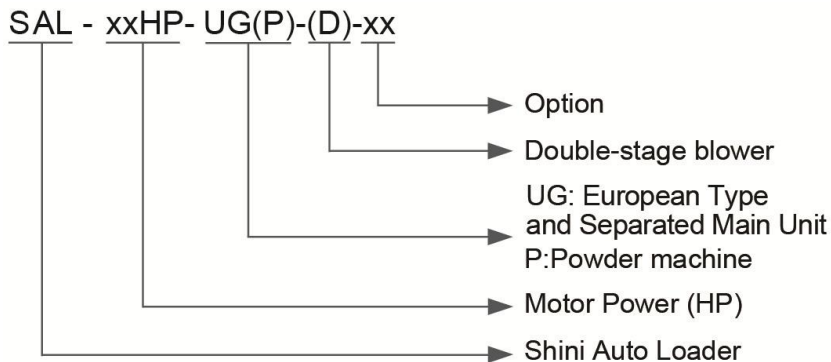

## 1.2 Feature

- Data backed up on EPROM in case of power failure and does not require back up battery.
- It consists of a cyclone dust separator and a dust collective bin to effectively reduce the load of filter.
- Function for setting regrind mix ratio via optional SPV-U.
- Standardly equipped with warning lamp as the alarm device.
- SAL-5HP-UG and models above, all series of SAL-UGP are standard equipped with the vacuum breaking valve.

All service work should be carried out by a person with technical training or corresponding professional experience. The manual contains instructions for both handling and servicing. Chapter 6, which contains service instructions intended for service engineers. Other chapters contain instructions for the daily operator.

Any modifications of the machine must be approved by SHINI in order to avoid personal injury and damage to machine. We shall not be liable for any damage caused by unauthorized change of the machine.

Our company provides excellent after-sales service. Should you have any problem during using the machine, please contact the company or the local vendor.

Headquarter and Taipei factory:

Tel: (886) 2 2680 9119

Shini Plastics Technologies (Dongguan), Inc:

Tel: (86) 769 8111 6600

Shini Plastics Technologies India Pvt.Ltd.:

Tel: (91) 250 3021 166

### 1.3 Technical Specifications

#### 1.3.1 Dimensions

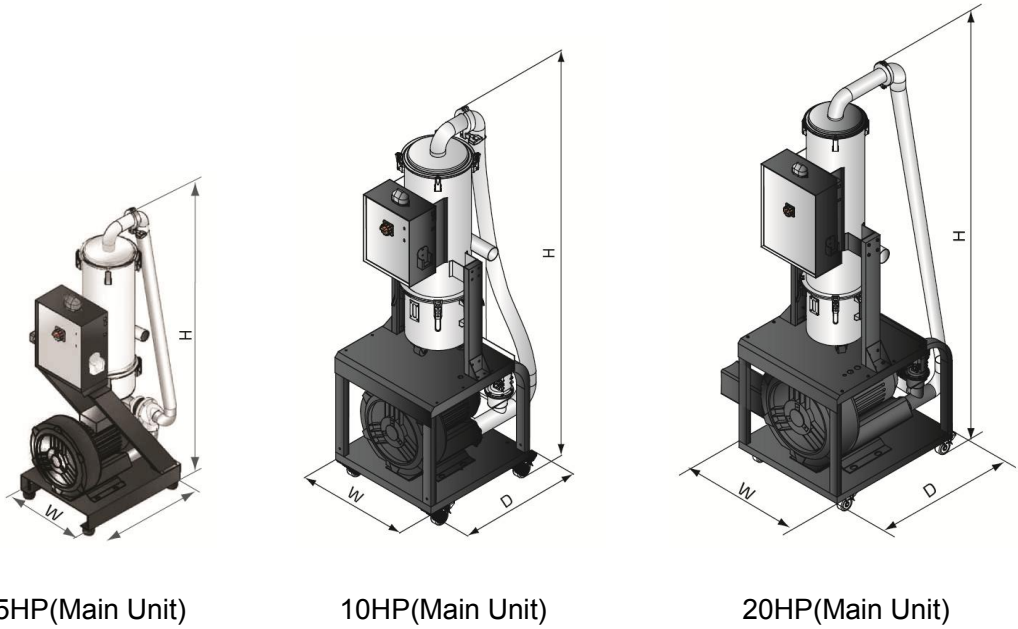

Picture 1-1: SAL-UG Dimensions

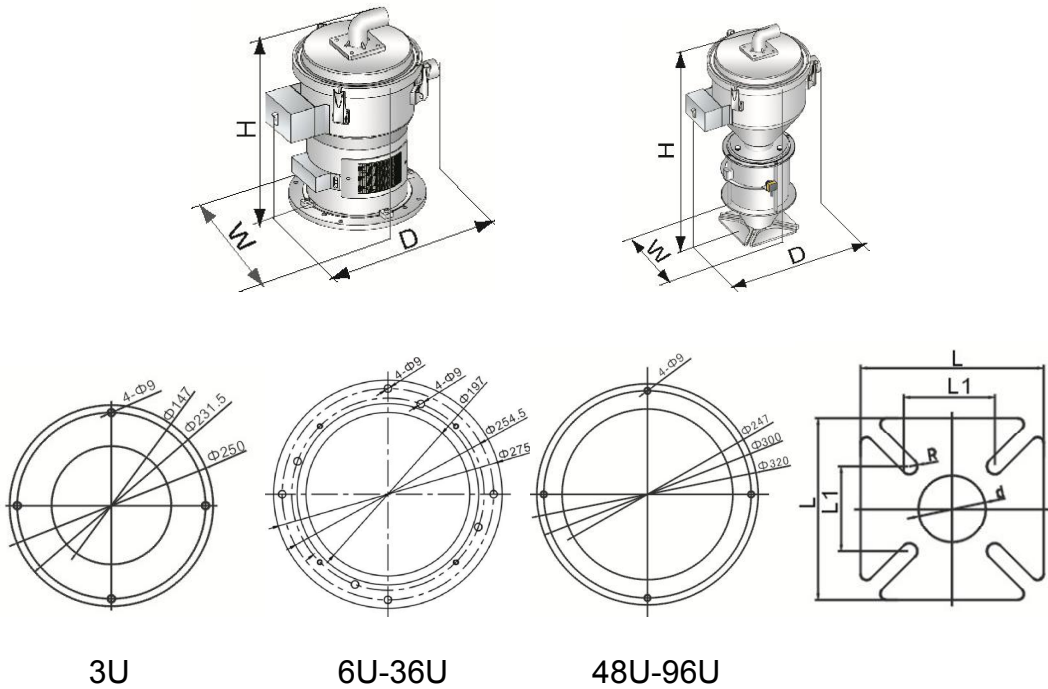

Picture 1-2: Dimensions of Material Hopper

Chart 1-1: Hopper Base Installation Size Chart

Model	L(mm)	L1(mm)	d(mm)	R(mm)
SHR-24U	120	50	40	R6.5
SHR-24U -E	150	70	55	R6.5
SHR-36U	180	80	55	R6.5
SHR-48U	180	85	80	R6.5

### 1.3.2 Specifications

Chart 1-2: Specifications

Main Unit					Hopper Receiver				Loading Pipe Dia. (Inch)	Air Suction Pipe Dia. (Inch)	Loading Capacity (kg/hr)
Model	Ver.	Motor Power (kW) (50 / 60Hz)	Dimensions (mm) H×W×D	Weight (kg)	Recommended Model	Hopper Capacity (L)	Dimensions (mm) H×W×D	Weight (kg)			
SAL -5HP-UG	B	3.75 / 4.2 (3Φ)	1380×470×600	74	SHR-24U×1	24	690×315×400	9	2	2	1000
SAL-5HP -UG-D	B		1380×670×600	76	SHR-24U-E×1		1120×360×400	13			
SAL -10HP-UG	B	7.5 / 8.6 (3Φ)	1850×580×790	160	SHR-36U×1	36	930×315×400	11	2	2.5	1600
SAL-10HP -UG-D	A		1850×750×890	162							
SAL-20HP -UG-D	A	13 / 18.7 (3Φ)	2270×745×1000	236	SHR-48U×1	48	975×350×485	15	2.5	3	2000

Note: 1) "SHR-U-E" stands for photosensor hopper receiver,

"SHR-E" refers to vacuum hopper receiver.

2) Test condition of conveying capacity: Plastic material of bulk density 0.65kg/L,  
dia. 3~5 mm, vertical conveying height: 4m, horizontal conveying distance: 5m.

3) Power supply: 3Φ, 230/400/460/575VAC, 50/60Hz.

We reserve the right to change specifications

without prior notice.

### 1.3.3 Loading capacity

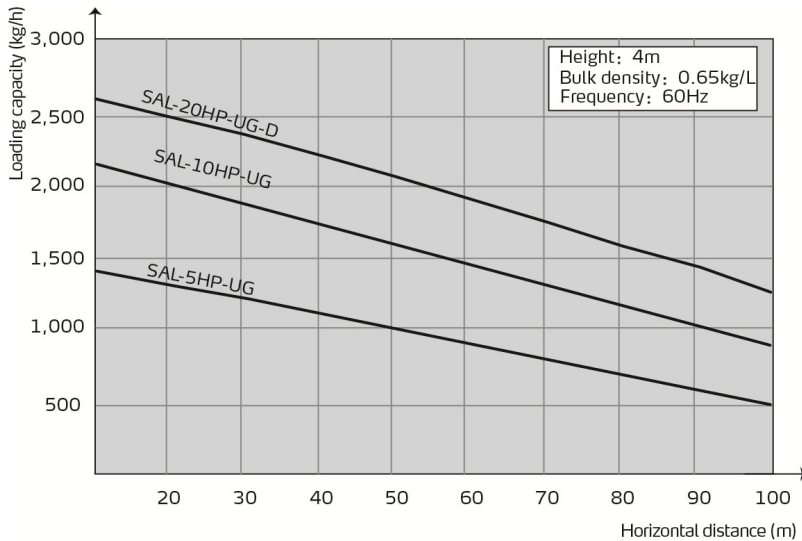

Picture 1-3: Loading Capacity

## 1.4 Safety Regulations

Strictly abide by the following safety regulations to prevent damage of the machine or personal injuries.

### 1.4.1 Safety Signs and Labels



All the electrical components should be installed by professional technicians.

Turn off the main switch and control switch during maintenance or repair.



Warning! High voltage!

This sign is attached on the cover of control box!



Warning! Be careful!

Be more careful at the place where this sign appears!



Attention!

No need for regular inspection because all the electrical parts in the control unit are fixed tightly!

## 1.4.2 Signs and Labels

	<ol style="list-style-type: none"><li>1. Please clean the suction filter regularly to avoid clogging and ensure proper loading capacity and long life span.</li><li>2. The one year warranty does not cover the suction filter, please clean the filter carefully.</li></ol>
---	--

## 1.5 Exemption Clause

The following statements clarify the responsibilities and regulations born by any buyer or user who purchases products and accessories from Shini (including employees and agents).

Shini is exempted from liability for any costs, fees, claims and losses caused by reasons below:

1. Any careless or man-made installations, operation and maintenances upon machines without referring to the Manual prior to machine using.
2. Any incidents beyond human reasonable controls, which include man-made vicious or deliberate damages or abnormal power, and machine faults caused by irresistible natural disasters including fire, flood, storm and earthquake.
3. Any operational actions that are not authorized by Shini upon machine, including adding or replacing accessories, dismantling, delivering or repairing.
4. Employing consumables or oil media that are not appointed by Shini.

## 2. Structure Characteristics and Working Principle

### 2.1 Main Functions

SAL-UG series "Euro" Separate-vacuum hopper Loader are suitable for conveying plastic granules over long distance. Utilizing high efficiency vacuum blower to produce vacuum in material hopper, plastic materials will then be fed into material hopper by outside pressure.

#### 2.1.1 Working Principle

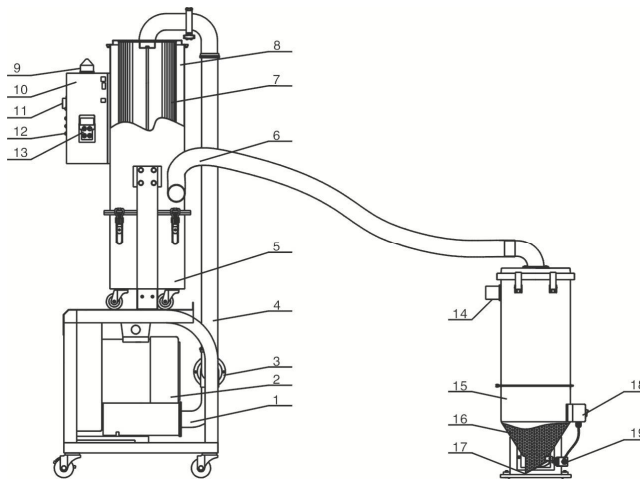

Names of Parts:

- |  |                               |                                    |
|--|-------------------------------|------------------------------------|
| 1. Blower suction pipe                     | 2. Blower                     | 3. Vacuum breaking diaphragm valve |
| 4. Steel wire hose                         | 5. Dust collecting barrel     | 6. Air suction pipe                |
| 7. Air filter                              | 8. Dust separating barrel     | 9. Control cabinet                 |
| 10. Alarm light 1                          | 11. Main switch               | 12. Alarm light 2                  |
| 13. Hand-held control panel                | 14. Material inlet            | 15. Material hopper                |
| 16. Raw materials                          | 17. Reverse stopping flap     |                                    |
| 18. Junction box Magnetic proximity switch | 19. Magnetic proximity switch |                                    |

Picture 2-1: Working Principle

After starting the machine, blower (1) begins to work to produce high-pressure vacuum inside of material hopper (15), meanwhile close the reverse stopping flap (17). Materials will be drawn into material hopper by pressure difference through material inlet (14). When material suction is completed, materials automatically fall down by self-gravity. Motor will start to work again when magnetic proximity switch (19) detects no materials left in the hopper. If the machine cannot suck

materials for three times, the red alarm lamp (10) and alarm lamp (12) on control box will blink.

When blower (2) sucks materials, the air inside the air-inputting pipe will be conveyed by the cyclone device into filter (7) for filtering. Few dust adhibits in the filter. After the blower finishes the suction, the vacuum breaking diaphragm valve (3) installed between the blower and filter will create a reverse impulsive airflow to shake down the dust sticking to the filter to the dust collection bucket (5).

## 2.2 Description of Electrical Components

### 2.2.1 Opposite-type Photoelectric Switch

- 1) Used for SAL-U-GE series for control of material conveying and material shortage alarm.
- 2) A pair of photoelectrical sensors is installed on the fastening screw of glass tube.



Picture 2-2: Opposite-type Photoelectric Switch

### 2.2.2 Magnetic Proximity Switch

- 1) Used for SAL-U-G series for control of material conveying and material shortage alarm.
- 2) It is installed at the bottom of material hopper.



Picture 2-3: Magnetic Proximity Switch

## 2.3 Optional Accessories

### 2.3.1 Air Accumulator

#### 2.3.1.1 Function of air Accumulator

In the case of much impurities or recycled materials included in raw materials, main unit can option with auto purging device of air accumulator for filter cleaning to improve conveying ability.

Add "A" at the end of the model code (Suitable for SAL-5HP-UG and models above)



Picture 2-4: Air Accumulator

#### 2.3.1.2 Specification of air Accumulator

Air accumulator: HxD=170x76mm

***Note: Please fix the air supply correctly. Air pressure not less than 4 bar.***

### 2.3.2 Cyclone dust separator



Picture 2-5: Cyclone Dust Separator

### 2.3.2.1 Cyclone Dust Separator Specifications

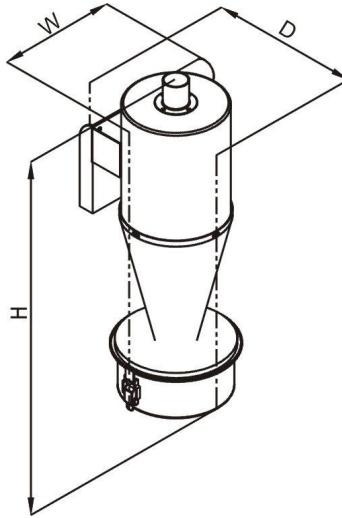

Picture 2-6: Dimension of Cyclone Dust Separator

Chart 2-1: Specification of Cyclone Dust Separator

Models	Dust collection bin capacity (L)	Dimension (mm) H x W x D	Pipe dia. (inch)
ACF-1	1.5	550 x 220 x 235	1.5
ACF-1	1.5	550 x 220 x 235	2

### 2.3.3 Buzzer

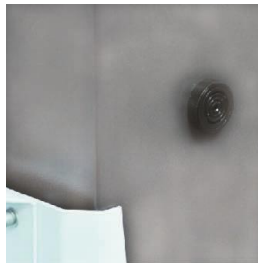

Picture 2-7: Buzzer

Buzzer is available as an option.

### 3. Installation and Debugging

This series of models only could be applied in working environment with good ventilation.



Read this chapter carefully before installation of the machine. Install the machine by following steps.

Power supply should be fixed by qualified technicians!

#### 3.1 Install the Machine on the Dryer

##### 3.1.1 Installation Elements

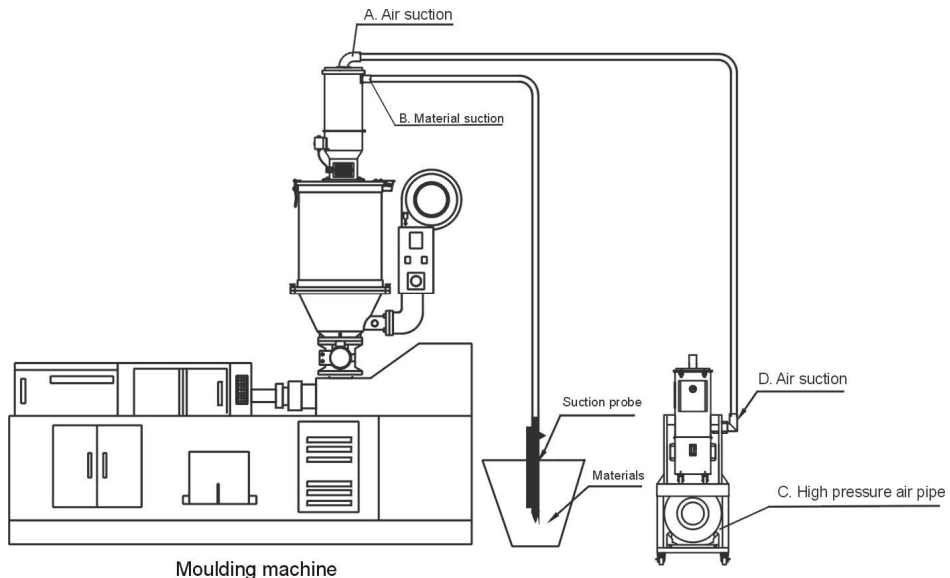

Picture 3-1: Installation Elements

##### 3.1.2 Installation Steps

- 1) Put the main body of the machine at a proper place and connect it with power supply.
- 2) Install material hopper onto the dryer and connect it with signal wires from the main body.
- 3) Use steel wire conveying hose to connect air suction pipe (A) on material hopper with air suction pipe (D) on main body. Material suction (B) should be connected with material suction probe (B) in material storage bin.
- 4) Connect high pressure air pipe (C) with air supply (pressure at 3~6kg/cm<sup>2</sup>).

### 3.1.3 Power Supply

Make sure that the power supply conforms with required specifications before installation. SAL-UG (E) Series should be Connected with 3Φ 400V 50Hz Power supply or other specifications if required.

***Note: Make sure main switch is turned off before you connect the power.***

## 4. Application and Operation





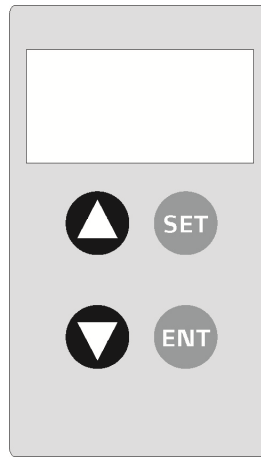

### 4.1 Start / Stop of the Machine

The start/stop of SAL-UG series is controlled by main switch in front of control box and alternative switch on the left side.

### 4.2 Keys on the Control Panel





Picture 4-1: Keys on the Control Panel

-  Choose an item or cancel current input.
-  Choose an item and store current input value. It is also used to clear the alarm when alarm occurs.
-  Increase setting value.
-  Decrease setting value.
-  +  Stop the machine in 3 sec. Press  to resume operation.









**Note: Re-start the machine, it resumes the initial screen.**

### 4.3 Parameter Setting

#### 4.3.1 Enter Basic Setting Mode

During normal operation, press  for about 1 sec. to enter [F.01] setting screen. [F.01] and its value show alternatively after 0.8 sec. If you want to set [F.04], the system will show [F.99]. [F.99] and its value will show alternatively after 0.8 sec. Input correct password to enter [F.01], then press  to switch to [F.04].

### 4.3.2 Modify a Parameter

Press  to increase parameter value. Keep on pressing  to quickly increase it's value until the maximum of it. Press  to decrease parameter value. Keep on pressing  to reduce it's value until the minimum of it. Press  to confirm parameter setting to store its value into the microprocessor and enter next setting item. If you did not change anything, press  to enter into next setting item. Press  to cancel parameter setting and return back to current setting screen. If you did not change anything, press  to enter into next setting item.

### 4.3.3 Finish Parameter Setting

Keep on pressing  for about 1 sec. to return to normal display mode. If you did not touch any keys for 20 seconds, the machine will return to normal display mode without storing any changes of the parameter.

### 4.3.4 Basic Parameter List

Para. code	Functions	Value		Note
F.01	Blower suction time when lacking material. Action code: S.02	10 seconds	5-127 seconds	-
F.02	Material mixing time This function will be started simultaneously with material conveying. It is set as a percentage of conveying time: it's value is calculated by following formula: conveying time×[F.02]%. Set it's value as 0 to disenable it.	0% Not enabled	0-100%	-
F.03	Material mixing frequency setting [F.02] means to start material mixing after a certain times of material conveying. Set [F.02] as 1, which means to start material mixing at every material conveying. Set it's value as 0 to cancel material mixing.	1	1-9	-
F.04	First layer lockup When to enter first layer setting, if [F.04] is not set as 0, then the screen will switch to [F.99], and require you to input a password before setting [F.01]. If the password is incorrect, the screen will return to normal display mode. Set [F.04] as 0 to cancel the password.	0	0-999	-

**Note: At delivery, the machine was not coded. You can set a code for the machine. In case of losing the code, please contact our company.**

## 4.4 Process Setting

### 4.4.1 Enter into process setting mode

Start the machine, press **SET** for about 1 sec. To enter basic setting mode. Then press **SET** and **ENT** at the same time to enter parameter [F.05] setting. [F.05] and it's value show alternatively. If you have set [F.12], the system will switch to [F.98]. Enter correct password to enter [F.05], then press **SET** to switch to [F.12].

### 4.4.2 Modify a Parameter

Press **▲** to increase parameter value. Keep on pressing **▲** to quickly increase it's value until the maximum of it. Press **▼** to reduce parameter value. Keep on pressing **▼** to reduce it's value until the minimum of it. Press **ENT** to confirm parameter setting and store it's value into the micro-processor and to enter next setting item. If you did not change anything, press **SET** to enter into next setting item. Press **SET** to cancel parameter setting and return back to current setting screen. If you did not change anything, press **ENT** to enter into next setting item.

### 4.4.3 Finish Parameter Setting

Keep on pressing **SET** for about 1 sec. to return to normal display mode. If you did not touch any keys for 20 secretary, the machine will return to normal display mode without storing any changes of the parameter.

### 4.4.4 Process Parameter List

Para. code	Functions	Value		Note
F.05	Material conveying delayed time The delayed time between first material conveying and later conveying action. 0 stands for no delaying time. Action code: S.06	0 seconds	9990 seconds	10 seconds for unit
F.06	Filter screen cleaning time before material conveying 0 stands for no filter cleaning action. Action code: S.01	3 seconds	0-99 seconds	-
F.07	Filter screen cleaning time after material conveying 0 stands for no filter cleaning action. Action code: S.03	3 seconds	0-99 seconds	-
F.C1	Cycle of mesh cleaning Mesh cleaning is done after several times' suction	3 seconds	1~99 seconds	-

F.08	<p>Check material discharging time</p> <p>Check material discharging time after material conveying. If there are directive signals, then the machine gets into next procedure. If not, add 1 to material shortage counter. When this situation continues until material shortage times exceed the setting value of [F.09], the machine will raise the alarm.</p> <p>Action code: S.04</p>	10 seconds	0-99 seconds	-
F.09	<p>Material shortage alarm</p> <p>If there are not any materials for discharging for several times, the machine would sound the alarm.</p> <ol style="list-style-type: none"> <li>1. The alarm will be reset if the machine can get material again.</li> <li>2. Press ENT on the control panel to clear the alarm</li> <li>3. Restart the machine.</li> </ol> <p>Action code: A.01</p>	3	1-9	-
F.10	<p>Material shortage counting and stop of the machine</p> <p>If there are not any materials for discharging, the machine would stop and sound the alarm.</p> <ol style="list-style-type: none"> <li>1. Press ENT to clear the alarm.</li> <li>2. Restart the machine. Set it's value as 99 to cancel this function.</li> </ol> <p>Action code: A.04</p>	99	[F.09]-99	-
F.11	<p>Setting waiting time before or after loading</p> <p>Set screen clean as 0, for either before or after each loading. So it is waiting to be shut before loading. If set 0 for screen clean after loading, so it is waiting to be shut after loading. Set as 0, which indicates no waiting before or after loading.</p>	30	999	-
F.12	<p>Second layer lockup</p> <p>When to enter second layer setting, if [F.12] is not set as 0, then the screen will switch to [F.98], and require you to input a password before setting [F.05]. If the password is incorrect, the screen will return to normal display mode. Set [F.05] as 0 to cancel the password.</p>	0	999	-

**Note: At delivery, the machine was not coded. You can set a code for the machine. In case of losing the code, please contact our company.**





## 4.5 Special Process Setting

### 4.5.1 Enter into Special Step Setting Mode

Enter into setting mode according to the steps described in 4.4. Press  to choose [F.11], then press  for about 1 sec. to enter into the setting of [F.13]. [F.13] and it's value will show alternatively.

### 4.5.2 Modify a Parameter

Press  to increase parameter value. Keep on pressing  to quickly increase it's value until the maximum of it. Press  to decrease parameter value. Keep

on pressing  to reduce it's value until the minimum of it. Press  to confirm parameter setting and store it's value into the microprocessor and to enter next setting item. If you did not change anything, press  to enter into next setting item. Press  to cancel parameter setting and return back to current setting screen. If you did not change anything, press  to enter into next setting item.

#### 4.5.3 Finish Parameter Setting

Keep on pressing  for about 1 sec. to return to normal display mode. If you did not touch any keys for 20 seconds, the machine will return to normal display mode without storing any changes of the parameter.

#### 4.5.4 Parameter List of Special Process Setting

Para. code	Functions	Value		Note
F.13	Buzzer working mode Setup buzzer working mode 0: uninterrupted sounding 1: Slow, interrupted sounding 2: Quick, interrupted sounding	0	0-2	-
F.14	Set buzzer sounding period Set buzzer sounding period: Set [F.13] as 999 to cancel buzzer sounding function.	999	999	-
F.15	First carbon brush alarm When carbon brush working hours [F.17] get to a certain point, [F.14] will raise the alarm. Please replace the carbon brushes. The alarm will last 5 minutes, and will repeat every 15 minutes until [F.17] set as 0. Set [F.14] as 0 to cancel this function. Action code: A.05	0 (SAL-UG invalid)	0-999	Unit = 10 Hrs
F.16	Second carbon brush alarm When carbon brush working hours [F.17] get to a certain point, [F.15] will raise the alarm. Please replace the carbon brushes. The alarm will last 5 minutes, and will repeat every 15 minutes until [F.17] set as 0. Set [F.15] as 0 to cancel this function. Action code: A.06	0 (SAL-UG invalid)	[F.14]-999	Unit = 10 Hrs
F.17	Third carbon brush alarm When carbon brush working hours [F.17] get to a certain point, [F.16] will raise the alarm until [F.17] set as 0. Please repalce the carbon brushes.Set [F.16] as 0 to cancel this function. Action code: A.07	0 (SAL-UG invalid)	[F.15]-999	Unit = 10 Hrs

F.18	Carbon brush usage record Checking and clear the working hours of carbon brush. Clear carbon brush working hours: set its value as 0, press ENT to confirm.	0	0-999	Set"0": can cel the value
F.19	Motor startup protective switch Set to on or off the motor startup protective switch 0: if it is on, which indicates slow speed protection of the start up loading motor 1: if it is off, which indicates full speed protection of the start up loading motor.	0	0: soft start on 1: soft start off	-
F.20	Motor Delay Stop Time When motor delay stop, vaccum breaking valve is opened and suck up air, to cool conveying blower and avoid starting/stopping frequently. Olny suitable for SAL-UG/UGP Not suitable for SAL-U. Must be set to "0".	0	0~999 seconds	-

**Note: At delivery, the machine was not coded. You can set a code for the machine. In case of losing the code, please contact our company.**

## 4.6 Explanation of Operation Procedures

### 4.6.1 Operation Procedures



The machine can work without control panel connected with it. The following is an explanation of operation procedures.

Indicators	Action code	Operation procedures	Relative parameter	Parameter description	
				Default	Range
Red light flickering	S. 01	Filter cleaning	F. 06	3 seconds	0-99 seconds
	S. 02	Material suction	F. 01	10 seconds	5-127 seconds
		Masterbatch suction	F.02	0%	0-100%
			F. 03	3	1-9 times
	S. 03	Filter cleaning and material falling into storage bin	F. 07	3 seconds	0-99 seconds
	S. 04	Wait until materials completely discharged	F. 08	10 seconds	0-99 seconds
	S. 05	Check alarm information (instantly completed, no display on control panel.)	-	-	-
	S. 06	Delayed time for material conveying.	F. 05	0 seconds	0-999 seconds
Green light shines	-	Time for material conveying confirmation	-	-	-

## 4.6.2 Alarms

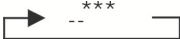
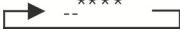
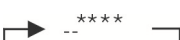
### Alarm information display and relative solutions.

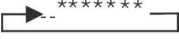
Red alarm light	Code	Possible reasons	Solutions	Remarks
	[A.01]	<p>Material shortage alarm [F.9]</p> <ol style="list-style-type: none"> <li>1. Material loading time is too short.</li> <li>2. Can not get any materials.</li> <li>3. Conveying hose blocked,</li> <li>4. Not enough suction power.</li> </ol>	<ol style="list-style-type: none"> <li>1. Add material.</li> <li>2. Increase material conveying time.</li> <li>3. Stop the machine and check the conveying hose.</li> </ol> <p>The alarm will be cleared when the machine can again load the material, or by pressing ENT on the control panel or by cutting off power supply.</p>	
	[A.03]	<p>Filter trouble alarm</p> <ol style="list-style-type: none"> <li>1. Filter blocked</li> </ol>	<ol style="list-style-type: none"> <li>1. Stop the machine to clean filter screen or replace it.</li> </ol> <p>The alarm will be cleared by cutting off the power or press ENT on the control panel.</p>	
	[A.04]	<p>Non-operation alarm [F.10]</p> <ol style="list-style-type: none"> <li>1. After a certain period time of material shortage, the machine will stop working.</li> </ol>	<p>Please refer to the solutions of [A.01] or modify the value of [F.10].</p> <p>The alarm will be cleared by cutting off the power or press ENT on the control panel. Please fix the control panel onto the machine and modify its value.</p>	
	[A.05]	<p>First carbon brush alarm</p> <p>When carbon brush working hours [F.17] gets to a certain point(800 hrs), [F.14] will raise the alarm.</p>	<p>Please prepare the carbon brush for replacement.</p> <p>The alarm will last for 5 minutes.</p> <p>The machine will repeat the alarm every 15 minutes until you reset carbon brush working hour.</p>	

Red alarm light	Code	Possible reasons	Solutions	Remarks
	[A.06]	<p>Second carbon brush alarm When carbon brush working hours [F.17] gets to a certain point(1000 hrs), [F.15] will raise the alarm.</p>	<p>Please replace the carbon brush and reset carbon brush working hour. The alarm will last for 5 minutes. Themachine willl repeat the alarm every 15 minutes until you reset carbon brush working hour.</p>	
	[A.07]	<p>Third carbon brush alarm When carbon brush working hours [F.17] gets to a certain point (1100 hrs), [F.16] will raise the alarm.</p>	<p>Please replace the carbon brush and reset carbon brush working hour. The machine won't stop the alarm until carbon brush working hour is reset.</p>	

--Denotes the light is off, \*Stands for flash of the light.

## 5. Trouble-shooting

Failures	Possible reasons	Solutions
Motor does not work long after material discharge.	1. Main power switch or control switch is off or poorly connected.	1. Turn on main switch and control switch and make sure they are well connected.
	2. Poor contact of magnetic proximity switch.	2. Adjust or replace.
	3. Signal wire is broken.	3. Reconnect
Motor keeps on working after material hopper is full-loaded.	Contactator malfunction.	Repair or replace contactor
Motor can not fully load material hopper, or machine sounds material shortage alarm.	1. No materials left for conveying.	1. Adding material.
	2. Air pipe breakage.	2. Firmly lock it or replace.
	3. Cloth filter is blocked.	3. Clean cloth filter.
Motor can not work.	Phase shortage or motor is burt out.	Check or replace.
Fuse melts each time you turn on the machine.	Short circuit or motor is burt out.	Check electrical circuit.
Motor overload alarm	1. Filter screen is blocked.	Clean the filter screen and press Reset on the overload relay.
	2. Phase shortage	Check the electrical circuit and press Reset on the overload relay.
Poor material liquidityin the pipe	Over or lack of air quantity	Adjust air inlet location of the suction box. Avoid small bending of the elbow.

## 6. Maintenance and Repair

**Note: All the repair work should be done by professionals in order to prevent personal injuries and damage of the machine.**

Main body, Filter Inspection and Storage Hopper Cleanup

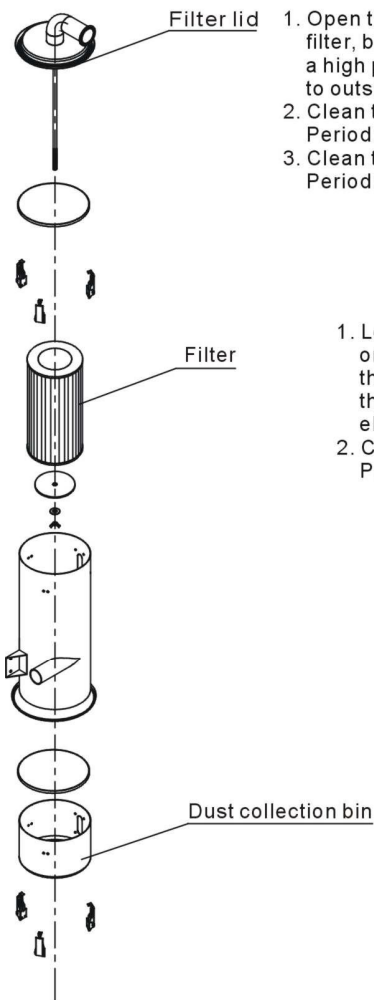

1. Open the filter lid and remove the filter, blow away the dust on it with a high pressure air gun from inside to outside.
2. Clean the filter.  
Period: daily
3. Clean the dust collection bin.  
Period: daily

Hopper, Screener

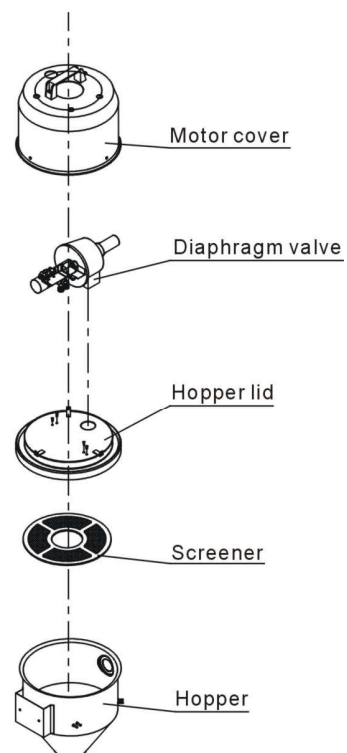

1. Loosen the snap hook on the hopper, remove the hopper lid, take out the screener and eliminate the dust on it.
2. Clean the Screener.  
Period: daily

### 6.1 Material Hopper

Clean material hopper periodically or when you find conveying capacity reduced. Please loose the spring clips, take down the hopper lid, and take out filter screen. Remove all the dusts and fines on filter screen and inside of material hopper.

## 6.2 Main Body

Take out the air filter to make it clean periodically or when you find conveying capacity reduced. Always keep smooth air flow through air filter to maintain good conveying capacity.

Cleaning steps:

- 1) Loosen spring clips of filter cover and butterfly screws, and take out the filter.
- 2) Remove the dusts adhering to the filter to keep good suction power.

## 6.3 Glass Tube

When you find that there are material grains clinging to the inner surface of glass tube, please make it clean timely to keep proper function of the machine.

- 1) Loosen the stainless steel pipe clamp and take down the installation flange.
- 2) Blow the glass pipe with the air gun according to the direction of arrow to blow away materials on the glass pipe or clean it with cloth.

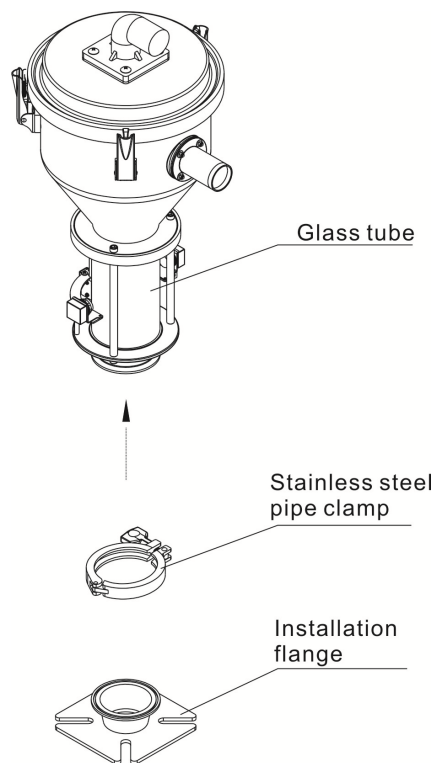

**Note: Be careful not to break glass tube during cleaning.**

## 6.4 Reed Switch, Photoelectric Switch

### Reed switch

When the indicator of the reed switch doesn't work, check the switch contact and replace with a new one if it doesn't work well.

- 1) Unscrew the outer box of the sensor.
- 2) Adjust the depth or move position the sensor inserted into the box, the indicator lamp lights means that magnetism has been detected and the switch is well worked.
- 3) If magnetism cannot be detected by magnets, please check whether the switch is bad contacted or damaged.

### Photoelectric Switch

When the indicator of the photoelectric switch doesn't work, check the switch contact and replace with a new one if it doesn't work well.

- 1) Check whether the wires are bad contacted.
- 2) Please replace with a new one if the switch is damaged.

## 6.5 Weekly Checking

- 1) Check if there are broken electrical wires or not. Replace the broken wires immediately.
- 2) Check the function of the keys on the control panel.
- 3) Check if screws at material inlet and the seal ring are loose or not.

***Note: Cut off power supply when you check electrical wires.***

## 6.6 Monthly Checking

- 1) Check if the clips of hopper lid is loose or not.
- 2) Check if the reverse stopping flap is out of shape. If it is, please replace it.
- 3) Check the performance of magnetic proximity switch or photo sensor. If there is poor contact, place fix the problem or replace it.

## 6.7 Maintenance Schedule

### 6.7.1 About the Machine

Model \_\_\_\_\_ SN \_\_\_\_\_ Manufacture date \_\_\_\_\_

Voltage \_\_\_\_\_  $\Phi$  \_\_\_\_\_ V Frequency \_\_\_\_\_ Hz Power \_\_\_\_\_ kW

### 6.7.2 Installation & Inspection

- Check if the takeover pipe has been correctly connected.
- Check if that pipe is locked up by clips.
- Check if mounting base is locked tightly.

#### Electrical Installation

- Voltage: \_\_\_\_\_ V \_\_\_\_\_ Hz
- Fuse melting current: One-phase: A \_\_\_\_\_ Three-phase: \_\_\_\_\_ A
- Check phase sequence of power supply.

### 6.7.3 Daily Checking

- Check main power switch.
- Check filter mesh.
- Check working status of the motor.

### 6.7.4 Weekly Checking

- Check all the electrical cables.
- Check if there are loose connections of electrical components.
- Check the screw of the feed-in pipe's flange is loosed or not.
- Check the air filter.

### 6.7.5 Monthly Checking

- Check the spring lock on the hopper cover is loosed or not.
- Check the reversal stop piece is deformed or not.
- Check the performance of magnetic proximity switch/photoelectrical sensor.