

# **SCAD-U Series**

## **Compressed Air Dryer**

Date: Feb. 2013

Version: Ver.B (English)





## Contents

<b>1. General Description</b> .....	<b>9</b>
1.1 Coding Principle .....	10
1.2 Feature .....	10
1.3 Technical Specifications .....	13
1.3.1 Specifications .....	13
1.3.2 Outline Drawing.....	13
1.4 Safety Regulations .....	15
1.4.1 Safety Signs and Labels .....	15
1.5 Exemption Clause .....	18
<b>2. Structure Characteristics and Working Principle</b> .....	<b>19</b>
2.1 Main Functions .....	19
2.1.1 Working Principle Table (SCAD-6U and Models Below) .....	19
2.1.2 Working Principle Table (SCAD-12U and Models Above).....	20
2.2 Drawing and Parts List .....	21
2.2.1 Assembly Drawing (SCAD-1U~6U).....	21
2.2.2 Parts List (SCAD-1U~6U) .....	22
2.2.3 Assembly Drawing (SCAD-12U and Models Above).....	23
2.2.4 Parts List (SCAD-12U and Models Above) .....	24
2.3 Electrical Diagram .....	25
2.3.1 Main Circuit .....	25
2.3.2 Thermocouple and Terminal Layout.....	26
2.3.3 Electrical Components List.....	27
<b>3. Installation and Debugging</b> .....	<b>28</b>
3.1 Attentions during Installation.....	28
3.2 Installation Structure Demonstration.....	28
<b>4. Application and Operation</b> .....	<b>29</b>
4.1 Temp. Setup (SCAD-6U and Models Below).....	29
4.1.1 The Instruction for the Key Operation .....	29
4.2 Panel Instruction (SCAD-12U and Models Above) .....	31
4.2.1 Temp. Setup .....	33

4.2.2	PID Auto-tuning Setting.....	33
4.2.3	Intermittent Running Setup .....	33
4.2.4	Weekly Time Start Setup .....	35
4.2.5	Present Time Modification.....	37
4.2.6	Weekly Time Start.....	38
4.2.7	Lock Setup Way .....	38
4.2.8	The second level of Advanced Setting .....	38
4.2.9	Wrong Codes Remark.....	40
<b>5.</b>	<b>Trouble-shooting .....</b>	<b>41</b>
<b>6.</b>	<b>Repair and Maintenance.....</b>	<b>42</b>
6.1	Filter & Pressure Regulating Valve.....	43
6.1.1	Filter & Pressure Regulating Valve Drawing .....	43
6.1.2	Filter & Pressure Regulating Valve Operation steps .....	43
6.2	Filter .....	43
6.3	Maintenance Schedule .....	44
6.3.1	About the Machine .....	44
6.3.2	Installation & Inspection .....	44
6.3.3	Daily Checking .....	44
6.3.4	Weekly Check .....	44
6.3.5	Monthly Check .....	45

## Table Index

Table 1-1: Specifications .....	13
Table 2-1: Parts List (SCAD-1U~6U).....	22
Table 2-2: Parts List (SCAD-12U and Models Above).....	24
Table 2-3: Electrical Components List.....	27
Table 4-1: Specification of Control Panel (SCAD-12U and Models Above).....	32
Table 4-2: Wrong Codes remark (SCAD-12U and Models Above).....	40

### **Picture Index**

Picture 1-1: Outline Drawing (SCAD-6U and Models Below) .....	13
Picture 1-2: Outline Drawing (SCAD-12U and Models Above) .....	14
Picture 2-1: Working Principle Table (SCAD-6U and Models Below) .....	19
Picture 2-2: Working Principle Table (SCAD-12U and Models Above).....	20
Picture 2-3: Main Circuit .....	25
Picture 2-4: Thermocouple and Terminal Layout.....	26
Picture 3-1: Installation Structure Demonstration .....	28
Picture 4-1: Operation Panel (SCAD-6U and Models Below) .....	29
Picture 4-2: Operation Panel (SCAD-12U and Models Above).....	31
Picture 4-3: Intermittent Running Setup 1 .....	34
Picture 4-4: Intermittent Running Setup 2.....	34
Picture 4-5: Intermittent Running Setup 3.....	35
Picture 4-6: Weekly Time Start Setup 1.....	35
Picture 4-7: Weekly Time Start Setup 2.....	36
Picture 4-8: Weekly Time Start Setup 3.....	36
Picture 4-9: Weekly Time Start Setup 4.....	37
Picture 4-10: Weekly Time Start Setup 5.....	37

Picture 6-1: Filter & Pressure Regulating Valve Drawing ..... 43



## 1. General Description



Read this manual carefully before operation to prevent damage of the machine or personal injuries.



Forbidden to process flammable or toxic material!

Applicable for the small batch drying of commonly-used engineering plastics such as ABS and PS, also suitable for the pre-heating treatment before plastics molding.



**Model: SCAD-6U**

## 1.1 Coding Principle

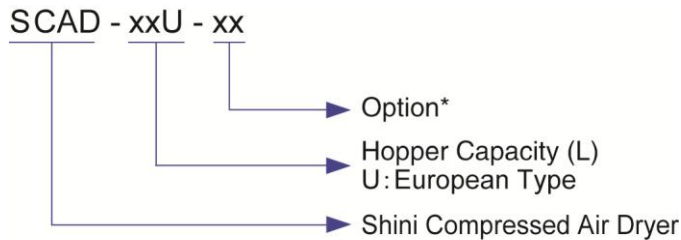

Note: \*

T=Timer    P=For Polished Hopper Inside

## 1.2 Feature

### 1) Standard configuration

- P.I.D. temperature controller can reach the accuracy of  $\pm 1^{\circ}\text{C}$ , The weekly timer is available with SCAD-12U~40U.
- Adopts compressed air to dry plastic materials with good and stable drying effect, and is not influenced by ambient temperature and humidity.
- SCAD-1~6U double-layer thermos table glass tube is easy to observe material level.
- Storage hopper of SCAD-12~40U is made of stainless steel to ensure no material contamination.
- Function of compressed air pressure detection makes a safe and reliable operation.
- Voltage-output type temperature controller collocating with SSR control loop can effectively prolong the lifespan of device.
- Equipped with overheat protection to avoid excessively high drying temperature.

- Equipped with air outlet filter, which is used to filter dried air exhausted to outside.
- Warning light can monitor machine normal operation.

## 2) Accessory option

- Optionally equipped with heatless regenerative air dryer, the dew-point temperature can reach  $-40^{\circ}\text{C}$  below. It mainly used to dry hygroscopic engineering plastics, and its power consumption is 35% lower than honeycomb dehumidifier.
- SCAD-1~6U can be optionally collocated with venturi loader VL-50 to achieve automatic material feeding; SCAD-12~40U can optionally be collocated with vacuum loader SAL-1U to achieve automatic material feeding.
- 24-hour auto start/stop timer is optional for SCAD-1~6U.

## Options

### Heatless Air Dryer HAD

#### Function:

The dew-point of compressed air can reach  $-40^{\circ}\text{C}$  under standard atmosphere which meets the requirement of drying materials and molding of plastics.

#### Installation:

It can be fixed on the molding machine or column of the foot stand. The air outlet and air inlet of SCAD-U are connected with air pipelines.

#### Notes:

Please clean up the filter regularly for fear that water or oil enter the drying

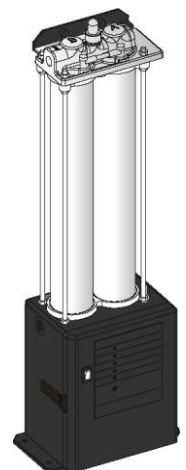

hopper which damages the molecular sieve and influences the dehumidifying performance.

All service work should be carried out by a person with technical training or corresponding professional experience. The manual contains instructions for both handling and servicing. Chapter 6, which contains service instructions intended for service engineers. Other chapters contain instructions for the daily operator.

Any modifications of the machine must be approved by SHINI in order to avoid personal injury and damage to machine. We shall not be liable for any damage caused by unauthorized change of the machine.

Our company provides excellent after-sales service. Should you have any problem during using the machine, please contact the company or the local vendor.

Headquarter and Taipei factory:

Tel: (886) 2 2680 9119

Shini Plastics Technologies (Dongguan), Inc:

Tel: (86) 769 8111 6600

Shini Plastics Technologies India Pvt.Ltd.:

Tel: (91) 250 3021 166

## 1.3 Technical Specifications

### 1.3.1 Specifications

Table 1-1: Specifications

Model	Drying Temp. max (°C)	Drying Hopper Capacity (L)	Heater Power (W)	Pressure Air		Dimensions (mm) H×W×D	Weight (kg)
				Pressure (kgf/cm <sup>2</sup> )	Flowrate (m <sup>3</sup> /hr)		
SCAD-1U	160	1	300	6~10	0.7	650×310×220	10
SCAD-3U		3			1.9	680×320×220	13
SCAD-6U		6			3.75	870×350×220	15
SCAD-12U		12	600		4.25	780×430×455	25
SCAD-20U		20	600		7	882×467×460	30
SCAD-40U		40	1200		14	1000×530×430	45

Note: 1) Pressure Air: Oil content  $\leq 3\text{mg/m}^3$ .  
 2) Power supply: 1 $\Phi$ , 230VAC, 50Hz / 60Hz.

We reserve the right to change specifications without prior notice.

### 1.3.2 Outline Drawing

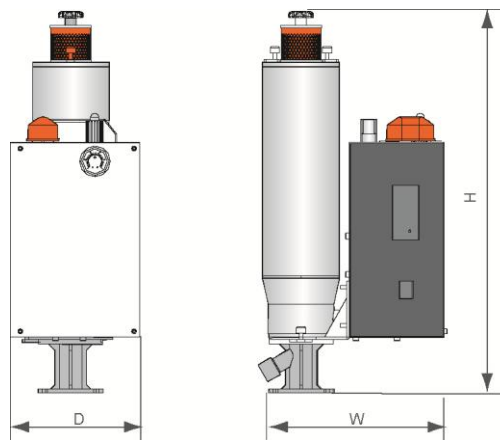

Picture 1-1: Outline Drawing (SCAD-6U and Models Below)

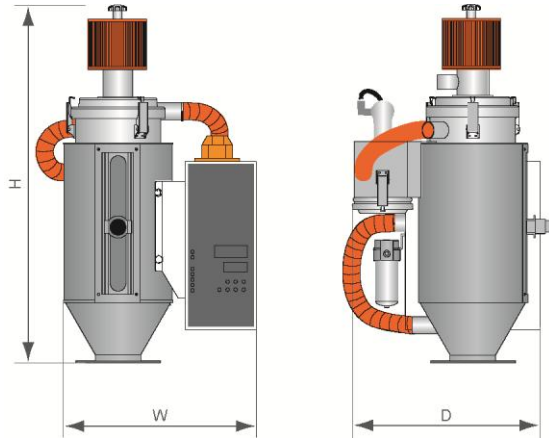

Picture 1-2: Outline Drawing (SCAD-12U and Models Above)

## 1.4 Safety Regulations



Notice!

The electrical installation should be done by qualified electricians. Before connect to power, make sure the specification of the power switch and rated current is proper and safe. Turn the switch into "OFF" position before power connection and also turn off both the power switch and auto running switch before maintaining.

### 1.4.1 Safety Signs and Labels



Hazard!

High voltage!

This label is attached to the housing of control box.



Caution!

Be careful when this label appears.



Warning!

Hot surface, easy to get hands burnt!

This label is attached at the housing of the electric heaters.



Attention!

No need for regular inspection because all the electrical parts in the control unit are fixed tightly!

### 1.4.2 Transportation and Storage of the Machine

Transportation

- 1) SCAD-U series are packed in crates or plywood cases with wooden pallet at the bottom, suitable for quick positioning by fork lift.
- 2) After unpacked, castors equipped on the machine can be used for ease of movement.
- 3) Do not rotate the machine and avoid collision with other objects during transportation to prevent improper functioning.

- 4) The structure of the machine is well-balanced, although it should also be handled with care when lifting the machine for fear of falling down.
- 5) The machine and its attached parts can be kept at a temperature from  $-25^{\circ}\text{C}$  to  $+55^{\circ}\text{C}$  for long distance transportation and for a short distance, it can be transported with temperature under  $+70^{\circ}\text{C}$ .

### Storage

- 1) SCAD-U series should be stored indoors with temperature kept from  $5^{\circ}\text{C}$  to  $40^{\circ}\text{C}$  and humidity below 80%.
- 2) Disconnect all power supply and turn off main switch and control switch.
- 3) Keep the whole machine, especially the electrical components away from water to avoid potential troubles caused by the water.
- 4) Plastic film should be used to protect the machine from dust and rains.

### Working environment

Indoors in a dry environment with max. temperature  $+45^{\circ}\text{C}$  and humidity no more than 80%.

### Do not use the machine

- 1) If it is with a damaged cord.
- 2) On a wet floor or when it is exposed to rain to avoid electrical shock.
- 3) If it has been dropped or damaged until it is checked or fixed by a qualified serviceman.
- 4) This equipment works normally in the environment with altitude within 3000m.
- 5) At least a clearance of 1m surrounding the equipment is required during operation. Keep this equipment away from flammable sources at least two meters.
- 6) Avoid vibration, magnetic disturbance at the operation area.

### Rejected parts disposal

When the equipment has run out its life time and can not be used any more, unplug the power supply and dispose of it properly according to local code.

### Fire hazard



In case of fire, CO2 dry powder fire extinguisher should be applied.

## 1.5 Exemption Clause

The following statements clarify the responsibilities and regulations born by any buyer or user who purchases products and accessories from Shini (including employees and agents).

Shini is exempted from liability for any costs, fees, claims and losses caused by reasons below:

1. Any careless or man-made installations, operation and maintenances upon machines without referring to the Manual prior to machine using.
2. Any incidents beyond human reasonable controls, which include man-made vicious or deliberate damages or abnormal power, and machine faults caused by irresistible natural disasters including fire, flood, storm and earthquake.
3. Any operational actions that are not authorized by Shini upon machine, including adding or replacing accessories, dismantling, delivering or repairing.
4. Employing consumables or oil media that are not appointed by Shini.

## 2. Structure Characteristics and Working Principle

### 2.1 Main Functions

#### 2.1.1 Working Principle Table (SCAD-6U and Models Below)

The working principle is that compressed air flows into heating case after through perssure regulating valve and solenoid valve, and finally exhaust into air. At the same time, the dew-point is reduced. The heated compressed air is blown into the heat-preservation hopper to dry materials, and it exhaust into air through filter to remove water in raw materials.

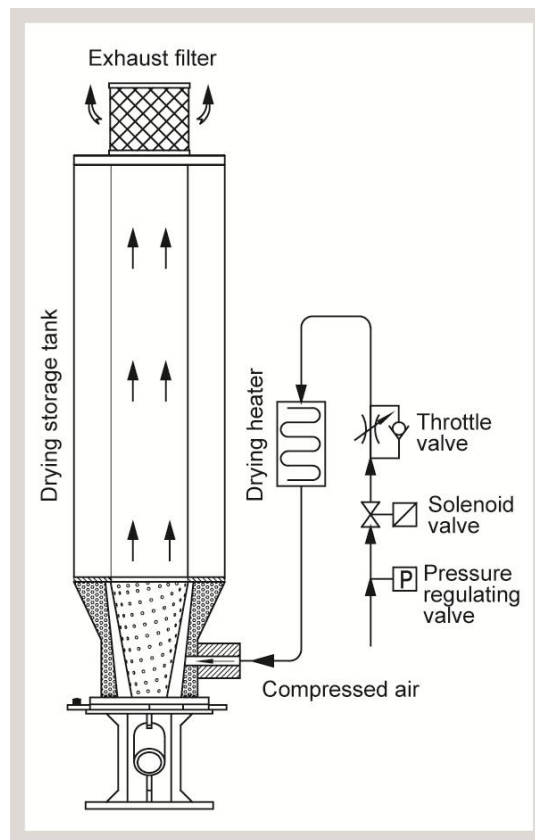

Picture 2-1: Working Principle Table (SCAD-6U and Models Below)

## 2.1.2 Working Principle Table (SCAD-12U and Models Above)

### Drying principle:

Under normal operation, hi-pressure air is blown into heating cabinet via solenoid valve and air diffusing equipment, then into drying hopper to dry up material. Air is discharged out through return air filter for recycle.

### Loading principle:

Hi-pressure air was controlled by solenoid valve and blown into suction pipe, then accelerating flow of air generates negative pressure to drive material feeding, which draw material into drying hopper. Air is discharged out through filter.

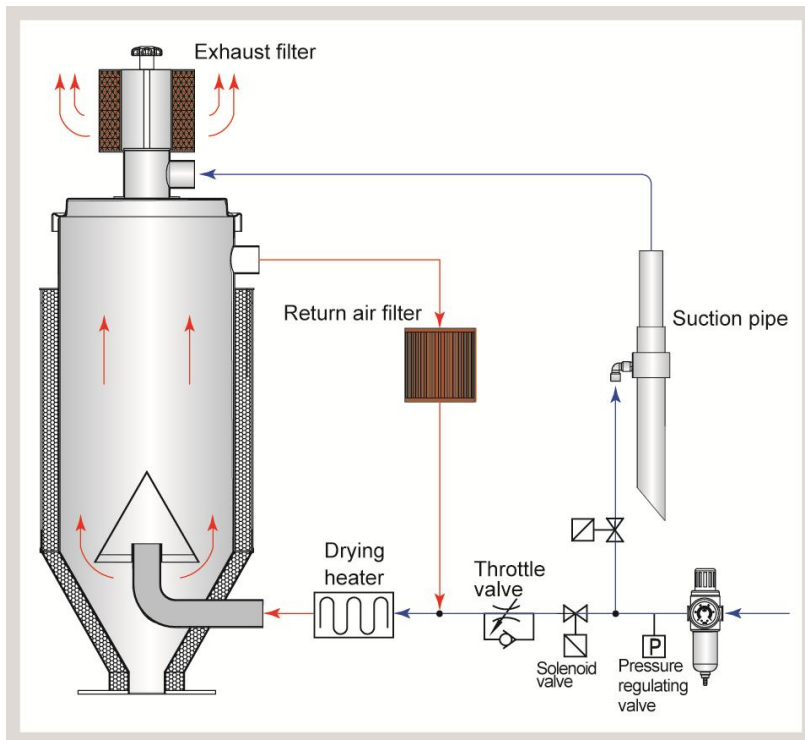

Picture 2-2: Working Principle Table (SCAD-12U and Models Above)

## 2.2 Drawing and Parts List

### 2.2.1 Assembly Drawing (SCAD-1U~6U)

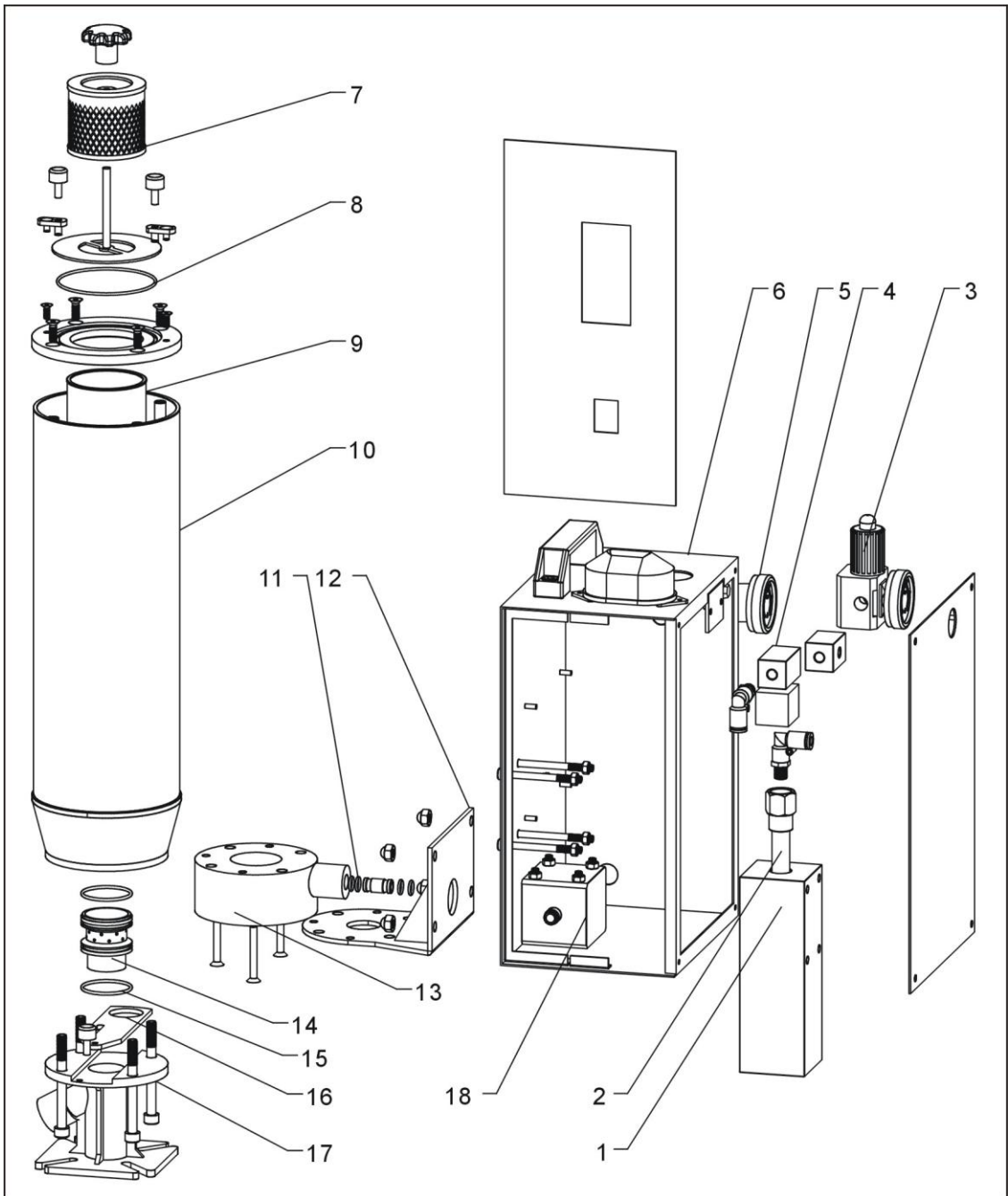

Remarks: Please refer to material list 2.2.2 for specific explanation of the Arabic numbers in parts drawing.

Picture 2-3: Assembly Drawing (SCAD-1U~6U)

## 2.2.2 Parts List (SCAD-1U~6U)

Table 2-1: Parts List (SCAD-1U~6U)

No.	Name	Part No.		
		SCAD-1U	SCAD-3U	SCAD-6U
1	Heating case	-	-	-
2	Pipe heater**	BH40108000050	BH40108000050	BH40108000050
3	Pressure regulating valve GR-200-06*	YE30200060000	YE30200060000	YE30200060000
4	Solenoid valve *	BE32513000050	BE32513000050	BE32513000050
5	Pressure switch	YE15015000000	YE15015000000	YE15015000000
6	Control box	-	-	-
7	Filter **	YR50101700000	YR50101700000	YR550956000000
8	O type seal ring *	YR20258900000	YR20259800000	YR20125300100
9	Inside glass tube **	YW70765300000	YW70110500000	YW70130125000
10	Outside glass tube **	YW70132500000	YW70150450000	YW70180175000
11	O type seal ring *	YR20101800000	YR20101800000	YR20101800000
12	Fixed board of control box	-	-	-
13	Hopper base	-	-	-
14	Inner sleeve of the hopper	-	-	-
15	O type seal ring *	YR20412200000	YR20412200000	YR20412200000
16	Shut-off plate	-	-	-
17	Base	-	-	-
18	Heating case 2	-	-	-

\* means possible broken parts.

\*\* means easy broken part. and spare backup is suggested.

Please confirm the version of manual before placing the purchase order to guarantee that the item number of the spare part is in accordance with the real object.

### 2.2.3 Assembly Drawing (SCAD-12U and Models Above)

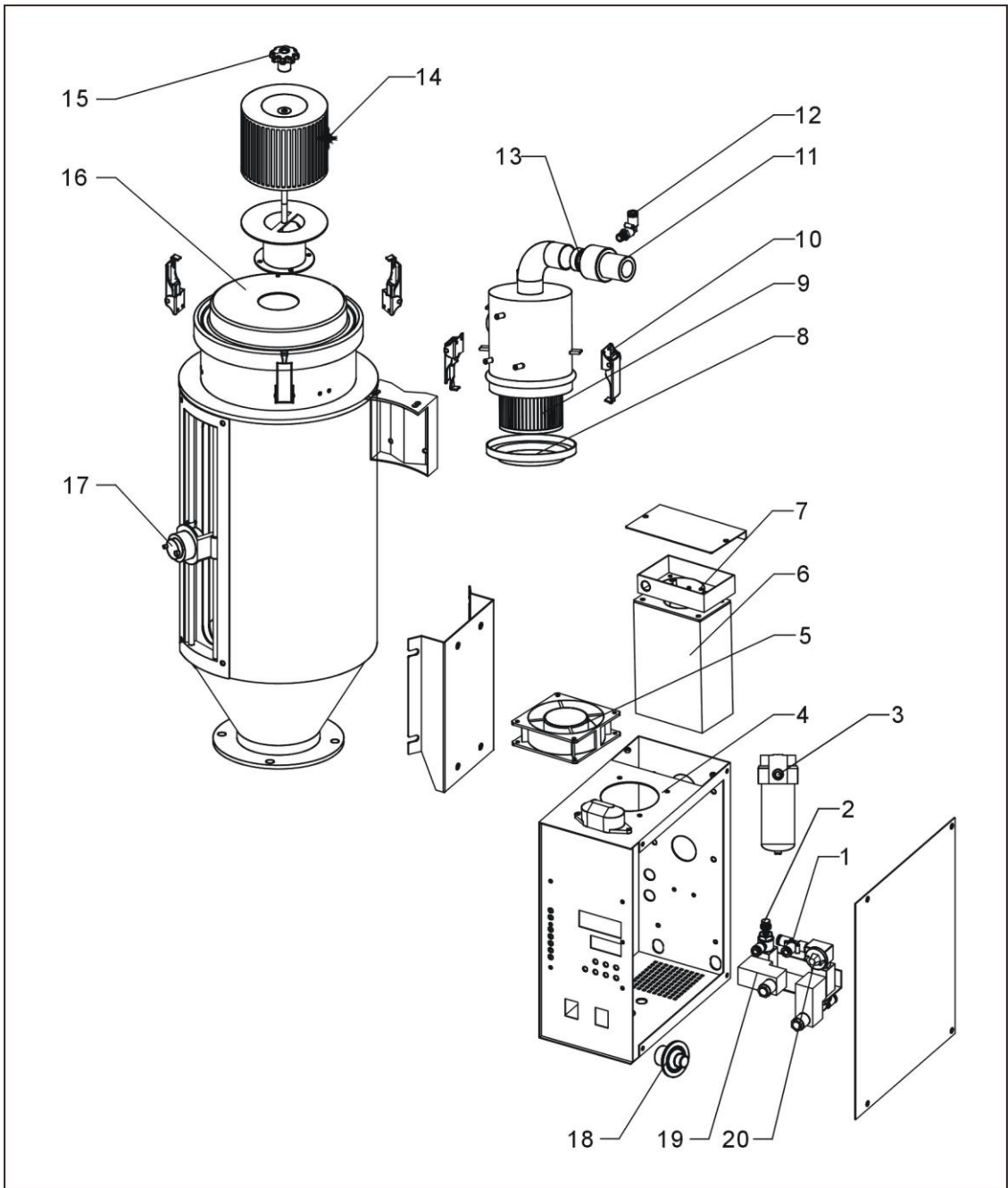

Remarks: Please refer to material list 2.2.4 for specific explanation of the Arabic numbers in parts drawing.

Picture 2-3: Assembly Drawing (SCAD-12U and Models Above)

## 2.2.4 Parts List (SCAD-12U and Models Above)

Table 2-2: Parts List (SCAD-12U and Models Above)

No.	Name	Part No.	
		SCAD-12U	SCAD-20U
1	Connection- T thread joint	YW80803800000	YW80803800000
2	Adjustable air pipe coupling	YW80083800000	YW80083800000
3	Filter & pressure regulating valve*	YE30200020000	YE30200020000
4	Control box	-	-
5	Exhaust fan *	YM60922500100	YM60922500100
6	Heating case	-	-
7	Pipe heater **	BH70122060050	BH70122060050
8	Filtering barrel lid	-	-
9	Filter ADC27**	YR50956000000	YR50956000000
10	Snap hook	YW02003000400	YW02003000400
11	Return air pipe coupling	-	-
12	L type thread joint	YW80083800200	YW80083800200
13	Material pipe coupling 1	-	-
14	Filter ADC18**	YR50128300100	YR50128300100
15	Star screw cap 5/16	YW09051600000	YW09051600000
16	material storage tank components	-	-
17	level sensor *	YE15002000000	YE15002000000
18	EGO*	BH90115000150	BH90115000150
19	solenoid valve *	BE32513000050	BE32513000050
20	pressure switch *	YE15015000000	YE15015000000

\* means possible broken parts.

\*\* means easy broken part. and spare backup is suggested.

Please confirm the version of manual before placing the purchase order to guarantee that the item number of the spare part is in accordance with the real object.

## 2.3 Electrical Diagram

### 2.3.1 Main Circuit

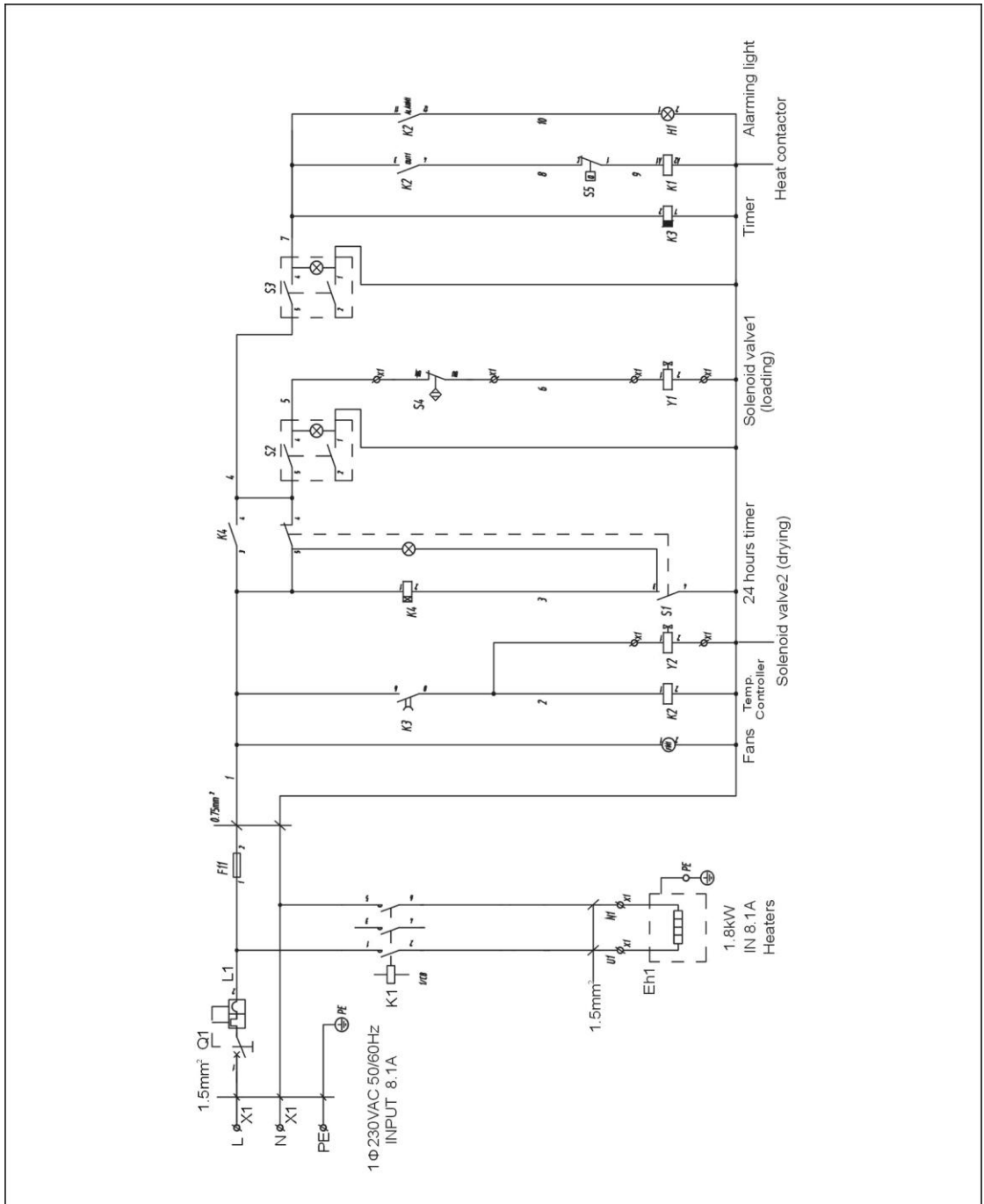

Picture 2-3: Main Circuit

### 2.3.2 Thermocouple and Terminal Layout

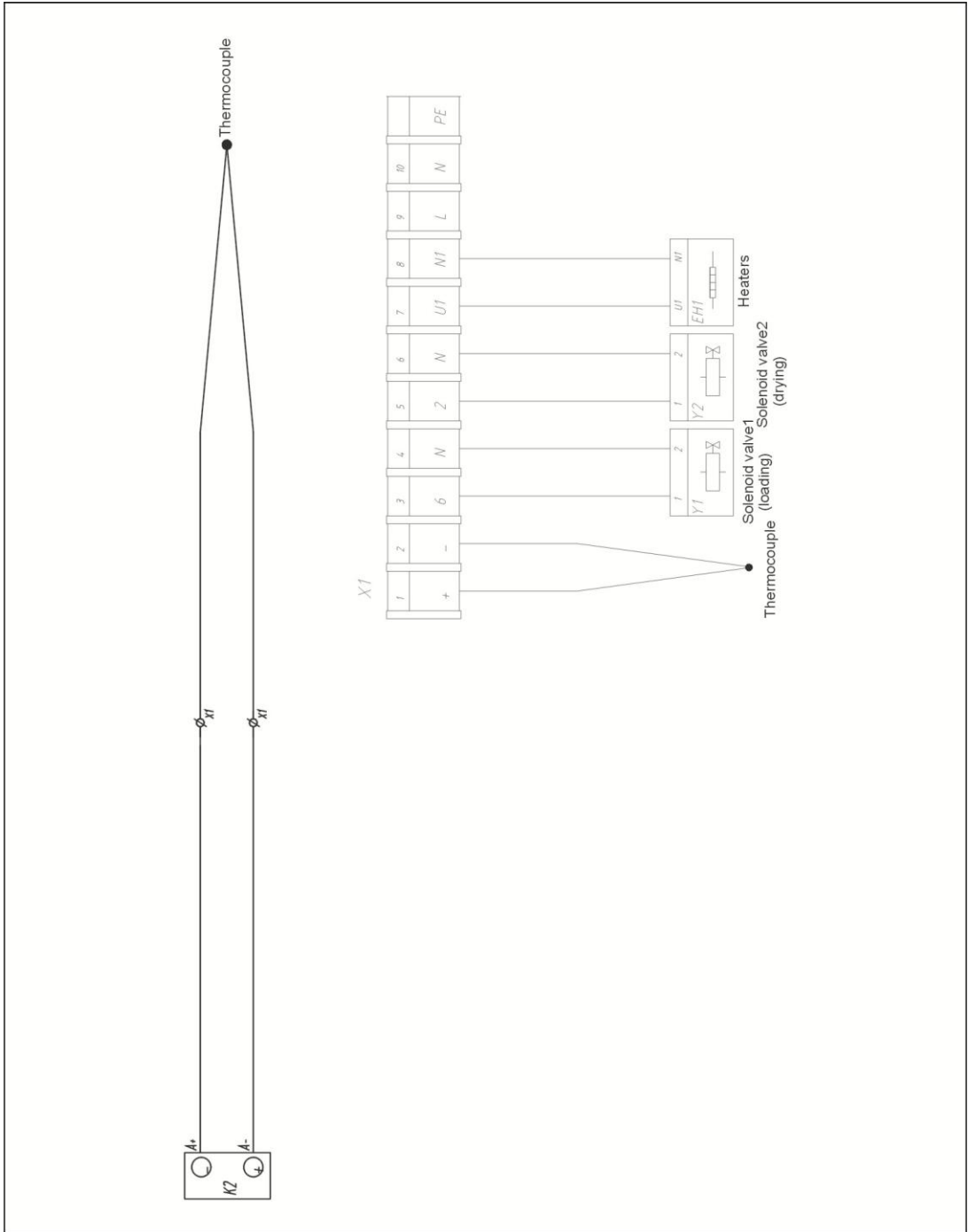

Picture 2-4: Thermocouple and Terminal Layout

### 2.3.3 Electrical Components List

Table 2-3: Electrical Components List

No.	Symbol	Name	Specification	Part No.	
				SCAD-12U	SCAD-20U
1	Q1	Transformer**	15A 1P	YE40600300000	YE40600300000
2	K1	Contact**	230V 50Hz	YE00411000100	YE00411000100
3	F11	Fuse**	2A	YE41001000000	YE41001000000
4	S1	Shift switch	5P (WH)	YE10220600000	YE10220600000
5	S2 S3	Shift switch	4P (WH)	YE10210400000	YE10210400000
6	S5	Over heat protector	250V5 (4) A	YE21503000000	YE21503000000
7	S4	Capacitance switch**	S: 15mm 20...250VAC	YE15002000000	YE15002000000
8	K2	Temp. controller*	230VAC 50/60Hz	YE80010200000	YE80010200000
9	K3	Time relay	230VAC 50/60Hz	YE86000300000	YE86000300000
10	K4	24hours timer	230VAC 50/60Hz	YE86002400000	YE86002400000
11	H1	Alarming light	230VAC 50/60Hz	YE80400200000	YE80400200000
12	Y1,Y2	Solenoid valve**	230VAC 50/60Hz	YE32213000200	YE32213000200
13	FM1	Fans*	230VAC 50/60Hz 0.1A	YM60922500100	YM60922500100
14	X1	Terminal block	25A	YE61001200000	YE61001200000
15	EH1	Heater**	1Φ230VAC	BH70120100050	BH70120100050

\* means possible broken parts.

\*\* means easy broken part. and spare backup is suggested.

Please confirm the version of manual before placing the purchase order to guarantee that the item number of the spare part is in accordance with the real object.

### 3. Installation and Debugging

#### 3.1 Attentions during Installation

- 1) Make sure that voltage of electricity matches with the nameplate.
- 2) Connect the electricity wire and earth wire according to local regulations.
- 3) Use independent electricity wire and power switch .The diameter of the wire should not be less than that of electric cabinet's wire.
- 4) The end of the electricity wire should be safe and firm.
- 5) Three-phase electricity and five wires are utilized. Connect the power to live wire, (N) to zero wire and (G) to ground wire.
- 6) Electric Power distribution demand.

Main power voltage:  $\pm 5\%$

Main power frequency:  $\pm 2\%$

- 7) Install pipe work system according to scheme of wiring.

#### 3.2 Installation Structure Demonstration

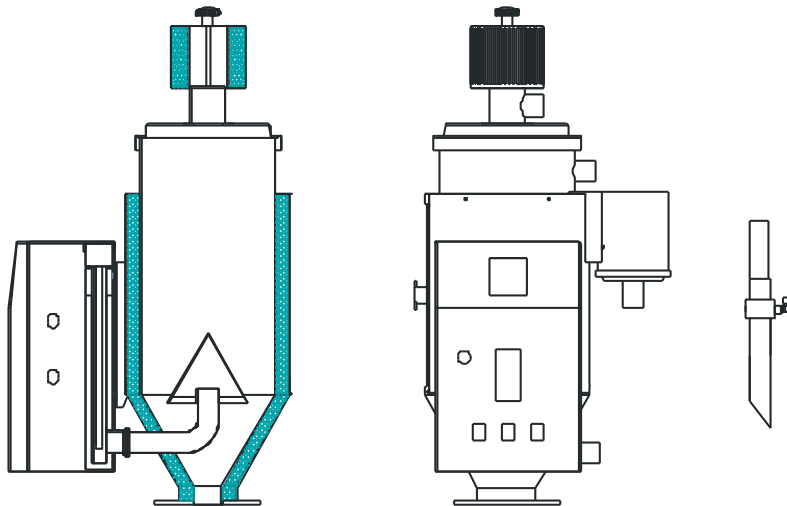

Picture 3-1: Installation Structure Demonstration

## 4. Application and Operation





Picture 4-1: Operation Panel (SCAD-6U and Models Below)

### 4.1 Temp. Setup (SCAD-6U and Models Below)

#### 4.1.1 The Instruction for the Key Operation

##### 1) The Selection Key for the Parameter Interface



1. In usual status, press this key to enter the parameter interface selection mode and also you can select the parameter interface by pressing that key. Press  key if you want to enter parameter mode.
2. Press selection key when in parameter mode to jump out the parameter mode and enter into parameter interface selection mode.
3. In the setup mode, press selection key to store parameter and jump out the setup mode. You can enter into setup mode to set the parameter.
4. In all the modes, press  for 2 seconds to jump back usual status.

##### 2) Setup Key



1. Press that key in usual mode to set the "value" directly.
2. Press that key in parameter interface selection mode to enter into setup mode to set "value".
3. Press that key in parameter mode to enter into setup mode to set "value".
4. Press that key in setup mode to select the setup number or store parameter and jump back to parameter mode.

#### Page up



1. The selection mode at the parameter interface, press "page up" key to enter into parameter mode.
2. At parameter mode, press "page up" key to select parameter from this interface.
3. At setup mode, press "page up" key to add the value of this parameter to its up limit.

#### Page down



1. The selection mode at the parameter interface, press "page down" key to enter into parameter mode.
2. At parameter mode, press "page down" key to select parameter from this interface.
3. At setup mode, press "page down" key to decrease the value of this parameter to its down limit.



+



Press both selection key and setup key for 2 sec: the auto display PID value programmer is activated or stopped.



+



Press both selection key and page up key for 2 sec: the manual output mode is activated or stopped.



+



Press both selection key and page down key for 2 sec: the reset output mode is activated or stopped.



Setup key press 8sec: ParameterPR55 Pass word setup.



Setup key press 10sec: Parameter LO2 lock setup.

## 4.2 Panel Instruction (SCAD-12U and Models Above)

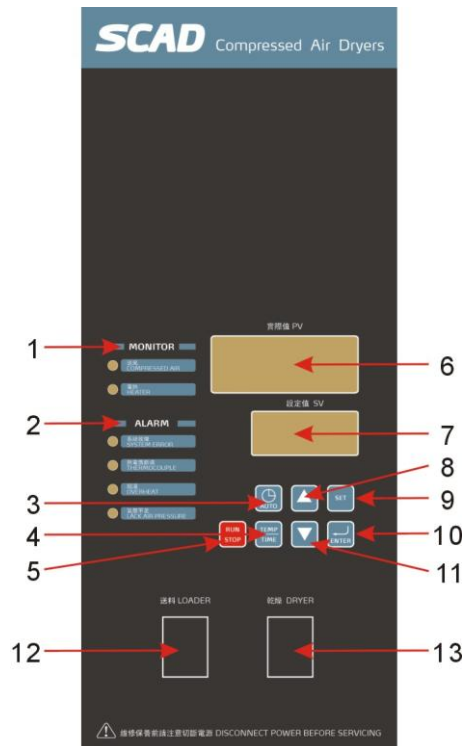

Picture 4-2: Operation Panel (SCAD-12U and Models Above)

There are three control switches, a temp. controller, a timer on the control panel. The three switches function as timing, loading, and drying respectively:

The operation steps for operating the hot air drying combination:

- 1) Connect to the 230V single phase loader power supply, and connect to the air source (the air pressure must be 4-6kgf/cm<sup>2</sup>). After confirmation that the breaker in the electric control box is closed, then start up the timing switch. The 24 hours timer works as a timing start/stop switch (omit this timer, if it doesn't need timing startup). When open the materials feeding switch, high pressure air will feed the materials automatically. The capacitance proximity switch in the drum will control the material level. When open the dry switch, the hot air will dry the materials. During drying, EGO protector and exceeding temperature alarm will work.

- 2) When need to stop the machine, first turn off the loading switch to stop the

loading work, then turn off the drying switch and the heaters stop immediately. After a period of heater's self-cooling, the solenoid valve for the air drying shut off and the temp. Controller displays "power cutoff".

Table 4-1: Specification of Control Panel (SCAD-12U and Models Above)

No.	Name	Functions	Remarks
1	Operation display area	Respectively display the working condition of blower and heater.	Green light on indicates operation condition while off means machine stop.
2	Fault display area	Display the alarm information of the machine.	Red light on means corresponding faults.
3	Timing start button	Regularly or intermittently start timing.	After setting the parameter, press the button and choose the start-up mode.
4	Temperature/time display alternative	Alternatively display temperature and time; set the parameter.	
5	Stop button	Control the on and off of the machine.	
6	LED display of present value (PV)	Display the present value of regeneration temperature or parameter code.	The value means drying temperature if drying heater is chose.
7	LED display of set value (SV)	Display the set value of regeneration temperature or parameter code.	The value means drying temperature if drying heater is chose.
8	Up key	Increase the set value.	
9	Set key	Enter into or drop out of the set mode.	
10	Enter key	Ensure the value input.	
11	Down key	Decrease the set value.	
12	Feeding switch	Start the feeding function.	
13	Heater switch	Start the heater.	

#### Operation steps:

- 1) Switch on the 230V single-phase power, connect to the air source and ensure the air pressure is in the range of 4~6kgf/cm<sup>2</sup>, the electric control. Turn on the feeding switch; the material is delivered automatically by high pressure air, the capacitive proximity switch on the hopper control the material level; press the RUN/STOP button and run the heater during which there is EGO overheating protection.
- 2) When there needs a stop, firstly turn off the feeding switch to stop the material feeding, then turn off the heaters. After a period of delay time, the

heater cools down and the solenoid valve closes and the temperature control displays power off.

#### 4.2.1 Temp. Setup

- 1) Press the "SET" key and the LED display begins to flash, press the ▲▼ key to set the temperature.
- 2) Press "ENTER" key to input the set value of the temperature.

#### 4.2.2 PID Auto-tuning Setting

- 1) Press the "SET" key and the LED display begins to flash. Press the "SET" and "ENTER" for 1.5s and enter the Auto-tuning setting mode, at this moment PV alternately displays "At" and present value and SV displays set value until the Auto-tuning setting finishes. Then the system returns to the normal operation.
- 2) If the Auto-tuning setting can not finish in 1 hour, the parameter will not be changed and the system will returns to the normal operation.
- 3) Pressing "ON/OFF" to go back to normal operation amid automatic calculation would not alter the original parameters.

#### 4.2.3 Intermittent Running Setup

Drying periods  $\rightleftarrows$  (0-ON) Stop periods (0-OFF)

- 1) Press "SET" key to change temp. setup value into time setup value, press "TEMP/TIMER" key to enter into setup mode, at this time "SV/setup value" flickers, "PV/setup value" displays "0-ON".



Picture 4-3: Intermittent Running Setup 1

- 2) PV displays "0-ON" to stand for drying periods. "0-OFF" stands for machine stop time. Press ▲▼ key to add or decrease time value of "SV/setup value". Each press of ▲▼ can add or decrease 15 mins set time.
- 3) Press "ENTER" to confirm the input time value and enter into "0-OFF" time setup items, then repeat step 2.



Picture 4-4: Intermittent Running Setup 2

Note: If set 0-ON as 04:00, 0-OFF as 05:00, which means drying periods is 4 hours stop time is 5 hours, then working for 4 hours and being stopped for 5 hours and repeat this so long.

- 4) Cancel intermittent running by entering 00.00 at "0-ON" or "0-OFF" press "ENTER" to confirm input value after time setup and enter into time setup

items from "1-ON" "week-ON".



Picture 4-5: Intermittent Running Setup 3

#### 4.2.4 Weekly Time Start Setup

- 1) After intermittent running setup, there comes the weekly time start setup. Press ▲▼ key to add or decrease the time value in "SV/setup value" of "1-ON". Press "ENTER" to confirm the input value and comes into the time setup items of "1-OFF" "MON-OFF".



Picture 4-6: Weekly Time Start Setup 1

- 2) Press ▲▼ key to add or decrease the time value in "SV/setup value" of "1-OFF". Press "ENTER" to confirm the input value and comes into the time setup items of "2-ON" "TUE-ON".



Picture 4-7: Weekly Time Start Setup 2

- 3) Do the same setup again and again to setup the ON/OFF time from Monday to Sunday.



Picture 4-8: Weekly Time Start Setup 3

- 4) Press "SET" key to back to normal status, after finish all the setup.

- 5) Setup all the "ON" to 00:00 if it is not for time start/stop.

Note:

- 1) F-20 functions as an password lock, hold on "SET" till the "PV" displays F-20.

2. Press key and only after input 0021 in the SV, can you press

"ENTER" to come into F-03 and other settings, so F-20 functions as an coded lock for entering into next parameters setup, which prevents the

modification from nonprofessionals.



Picture 4-9: Weekly Time Start Setup 4

3. F-03 stands for the selection of temperature unit. Press to shift between °C/°F then press “ENTER” to confirm.
4. F-04 is data lockup function, press key to shift between OFF / LOCK, LOCK is for locking up information, not able to input or change any data: OFF is for lockup cancellation.



Picture 4-10: Weekly Time Start Setup 5

5. F-05 stands for the function of temperature protection. Alarm will be launched if actual temperature were equal to or higher than the addition of setting temperature value and setting value. This temperature range is between 0 and 50, and default value is 15.

#### 4.2.5 Present Time Modification

- 1) Repeat the above steps until PV displays "TIME" to stand for present time.
- 2) Press ▲▼ key to add or decrease time.
- 3) Press "ENTER" key and PV displays "DAY" to stand for week days.
- 4) Press ▲▼ key to add or decrease days.
- 5) Press "SET" key to back to normal status after finish all the setup.

#### 4.2.6 Weekly Time Start

- 1) Activate the weekly time start after finish the time setup and the present time setup.
- 2) Press "AUTO" key at working or stop status to preset the time start/stop, the "PV" will display the time and temp. alternatively.
- 3) Press "AUTO" again if want to cancel that weekly time setup.

#### 4.2.7 Lock Setup Way

- 1) Press "SET" key down and release it till "PV" displays F-20.
- 2) Press ▲▼ key to make "SV" to 0021, then press "ENTER" key, the "PV" will display F-04.
- 3) F-04 are for LOCK function selection, press ▲▼ key to select LOCK or OFF.
- 4) Press ENTER or "SET" key after setup.
- 5) If select LOCK, the "SV" will display "LOCK" when pressing "SET" key, which means the parameters have been setup and not accessible to any change.

#### 4.2.8 The second level of Advanced Setting

- 1) Enter the first level of advanced setting and press "SET" and "Enter" meanwhile for 3 seconds till F-06 displays in PV..

- 2) Press ▲▼ to set SV into 0003 and press “Enter”, at this time F-06 displays in PV.
- 3) Now pressing ▲▼ can alter value, press “Enter” to input after confirming then jump to F-07.
- 4) If you want to leave the function setting, just press “SET”.
  1. F-06 stands for the passwords of second level.
  2. F-07 stands for proportional band of heating side (P); it is a preset value before delivery.
  3. F-08 stands for integration time of heating side (I); it is a preset value before delivery.
  4. F-09 stands for differential time of heating side (D); it is a preset value before delivery.
  5. F-10 stands for switch cycle of heating side; its preset value is 15 sec.
  6. F-16 stands for power deliver delay time of heater, it is adjustable, the unit is sec. (Heater begins to work after the blower starts the delay time setting.)
  7. F-17 stands for blower power-off delay time, it is adjustable, the unit is sec.. (Press the “ON/OFF” key and the heater stops, the blower stops after the delay time to avoid abnormal condition caused by high temperature.)
  8. F-18 stands for the protection of maximum temperature. Its setting range is 140~250. (When the drying temperature value is high than the system setting one, the machine stops and give an alarm to avoid overheating caused by other faults.)
  9. F-19 stands for micro switch time setting of honeycomb rotor. “OFF” functions as shut-off and “ON” functions as open. The setting range is 0~9999 with the unit is sec.. (Rotor detecting time, when the setting time is less than the time for the rotor rotate once, the micro switch periodic resets and detect whether the honeycomb is rotating.)

#### 4.2.9 Wrong Codes Remark

Table 4-2: Wrong Codes remark (SCAD-12U and Models Above)

<b>Wrong Codes</b>	<b>Remark</b>
E-01	Thermocouple break
E-02	Inverse phase
E-03	Heater overload
E-04	Overheat input for drying EGO
E-05	Drying temperature is higher than the max. setting temperature of the system
E-07	Overheat protection (when $PV \geq SV + \text{set value}$ , it alarms.)
E-08	Memory errors
E-09	Honeycomb rotor operation error
E-10	Overheat input for regenerative EGO
E-11	Reversed-phase of thermocouple
E-12	Auto-tuning errors

## 5. Trouble-shooting

Fault	Possible reasons	Solution
Open the loading switch and there is no loading work	1. Circuit fault.	1. Repair the circuit.
	2. The capacitance switch is not adjusted well or broken.	2. Adjust or replace the capacitance switch.
	3. Solenoid valve is broken.	3. Replace the solenoid valve.
Loading is over and still loading after shut the switch	1. Circuit fault.	1. Repair the circuit.
	2. The capacitance switch is not adjusted well or broken.	2. Adjust or replace the capacitance switch.
The temp. Can not reach the temp. Controller set temp.	1. The adjustment of EGO is too small in scale.	1. Adjust the EGO to 10°C above the setup temperature.
	2. The temp. Controller's problem.	2. Readjust the temp. Controller or replace it with a new one.
	3. The heater fault.	3. Replace the heater.
The system doesn't work normally after turn on any switch.	1. No power connection.	1. Connect to power.
	2. The circuit board is broken.	2. Replace it.
	3. Power fault.	3. Check the power.
	4. The control circuit fuse is melted.	4. Replace the fuse.

## 6. Repair and Maintenance

1. Filter cleaning. Period: Daily Method: unscrew the nuts and take out the filter, blow off the dust with compressed air.
2. Check is the sealing ring is damaged, or replaces a new one. Period: Monthly Check is the bolts and nuts. Period: Monthly

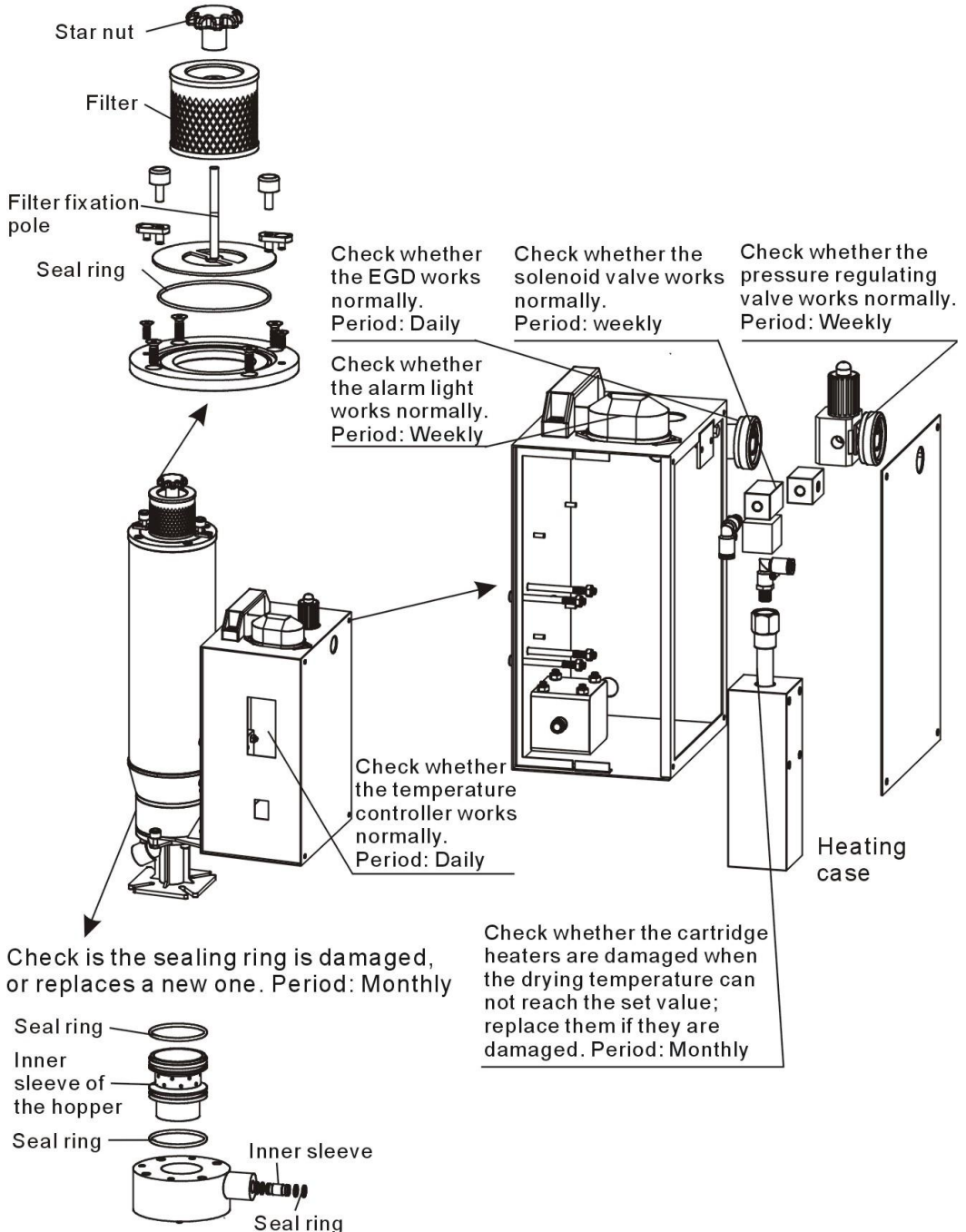

## 6.1 Filter & Pressure Regulating Valve

### 6.1.1 Filter & Pressure Regulating Valve Drawing

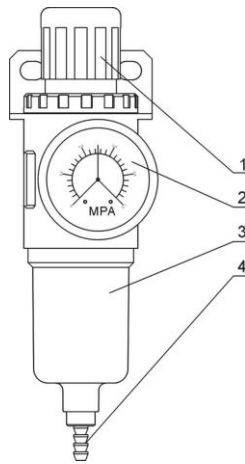

Parts list:

1. Pressure adjusting knob    2. Pressure gauge    3. Cup    4. Water outlet

Picture 6-1: Filter & Pressure Regulating Valve Drawing

### 6.1.2 Filter & Pressure Regulating Valve Operation steps

- 1) Switch on the air source.
- 2) Pull the black pressure adjusting knob 1 upward and rotate it, observe the pressure gauge 2, generally a 0.5 Mpa pressure is advisable.
- 3) Push back the black knob 1.

## 6.2 Filter

Clean the filter periodically , usually one time for a week;

Steps:

- 1) Take out filter.
- 2) Use compressed air to clean the lid and filter.
- 3) Use cloth to wipe out the empty internal face of the filter.
- 4) Install in opposite order after cleaning.



Caution: Do not let any scrap fall into the hopper when take the filter out.

## 6.3 Maintenance Schedule

### 6.3.1 About the Machine

Model \_\_\_\_\_ SN \_\_\_\_\_ Manufacture date \_\_\_\_\_

Voltage \_\_\_\_\_  $\Phi$  \_\_\_\_\_ V Frequency \_\_\_\_\_ Hz Power \_\_\_\_\_ kW

### 6.3.2 Installation & Inspection

- Check if the pipe are connected correctly
- Check if the pipe has any leakage
- Check if the sealed joint has any crack

Electrical Component Installation

- Voltage: \_\_\_\_\_ V \_\_\_\_\_ Hz
- Fuse melt current: 1 Phase \_\_\_\_\_ A 3 Phase \_\_\_\_\_ A
- Power phase sequence check

### 6.3.3 Daily Checking

- Check the function of switches.
- Check all wires of the machine.

### 6.3.4 Weekly Check

- Check if the joint point is loose.

### 6.3.5 Monthly Check

- Check the function of timer.