

SG-24N

Screenless Granulators

Date: Jul, 2012

Version: Ver.A (English)



Contents

1. General Description	9
1.1 Coding Principle	10
1.2 Feature	10
1.3 Technical Specifications	12
1.3.1 Technical Specifications	12
1.3.2 Dimensions	13
1.4 Safety Regulations	13
1.4.1 Safety Signs and Labels	13
1.4.2 Transportation and Storage of the Machine	15
1.5 Exemption Clause	17
2. Structural Features and Working Principle	18
2.1 General Description	18
2.1.1 Working Principle	18
2.2 Safety System	19
2.2.1 Emergency Stop Switch	19
2.2.2 Safety Switch	20
2.2.3 Gate Lock	20
2.3 Assembly Drawing	22
2.3.1 System Structure (SG-2417N)	22
2.3.2 Parts List (SG-2417N)	23
2.3.3 System Structure (SG-2427N)	25
2.3.4 Parts List (SG-2427N)	26
2.3.5 System Structure (SG-2436N)	28
2.3.6 Parts List (SG-2436N)	29
2.3.7 Cutting Chamber	31
2.3.8 Cutting Chamber Parts List	31
2.3.9 Blade Rest	32
2.3.10 Feed Box, Feed Port and Material Stopper	33
2.3.11 Feed Box, Feed Port and Material Stopper Parts List	33
2.3.12 Storage Bin	33
2.3.13 Storage Bin Parts List	34

2.3.14	Main Body.....	34
2.3.15	Main Body Parts List.....	34
2.4	Electrical Diagram.....	35
2.4.1	Main Circuit (400V).....	35
2.4.2	Control Circuit (400V).....	36
2.4.3	Electrical Components Layout (400V).....	38
2.4.4	Electrical Components List (400V).....	39
2.4.5	Main Electrical Circuit (230V).....	43
2.4.6	Control Circuit (230V).....	44
2.4.7	Electrical Components Layout (230V).....	46
2.4.8	Electrical Components List (230V).....	47
2.5	Electrical Components Description.....	50
2.5.1	Thermal Overload Relay.....	50
2.6	Options.....	51
2.6.1	30-second Instant Recycling System.....	51
2.6.2	Full-receiver Alarm Devices.....	51
2.6.3	Proportional Valves.....	52
3.	Installation and Debugging.....	53
3.1	Installation Notice.....	54
3.2	Installation Place.....	55
3.3	Installation of Bearing and Cutter Shaft.....	55
3.4	Installation of Reduction Gear.....	57
3.5	Installation of Feed Box, Feed Port and Storage Bin.....	58
4.	Operation Guide.....	60
4.1	Startup Pretest.....	60
4.1.1	Before the First Startup.....	60
4.1.2	After Startup for 2 Hours.....	60
4.1.3	After Startup for 20~30 Hours.....	61
4.2	Circuit Connection.....	61
4.3	Open the Feed Box and Storage Bin.....	61
4.3.1	Open the Feed Box.....	61
4.3.2	Open the Storage Bin.....	62
4.4	Shut the Feed Box and Storage Bin.....	62
4.4.1	Shut the Feed Box.....	62

4.4.2	Shut the Storage Bin.....	62
4.5	Start and Stop the Granulator	63
4.6	Motor Reversed Protective Function	64
5.	Trouble-shooting	65
5.1	Granulator Can Not Work.....	65
5.2	Stop Due to Other Reasons	65
6.	Maintenance and Repair	66
6.1	Repair	66
6.1.1	Replace the Blades.....	66
6.2	Transmission.....	69
6.2.1	Maintenance of Reduction Gear	69
6.3	Check and Maintenance of Gear Motor	69
6.4	Maintenance	70
6.4.1	Daily Check	70
6.4.2	Weekly Check.....	71
6.4.3	Monthly Check.....	71
6.5	Cleaning.....	71
6.6	Maintenance Schedule.....	73
6.6.1	About the Machine.....	73
6.6.2	Check after Installation	73
6.6.3	Daily Check	73
6.6.4	Weekly Check.....	73
6.6.5	Monthly Check.....	73
6.6.6	Check Half-yearly or Every 1000 Running Hours	74
6.6.7	3 year Checking.....	74

Table index

Table 1-1:	Technical Specifications.....	12
Table 2-1:	Parts List (SG-2417N)	23
Table 2-2:	Parts List (SG-2427N)	26
Table 2-3:	Parts List (SG-2436N)	29
Table 2-4:	Parts List.....	31
Table 2-5:	Blades Rest Parts List	32

Table 2-6: Feed Box, Feed Port and Material Stopper Parts List	33
Table 2-7: Storage Bin Parts List	34
Table 2-8: Main Body Parts List.....	34
Table 2-9: SG-2417N/2427N Parts List (400V)	39
Table 2-10: SG-2436N PartsList (400V)	41
Table 2-11: SG-2417N/2427N Parts List (230V)	47
Table 2-12: SG-2436N Parts List (230V).....	49

Picture index

Picture 1-1: Dimensions	13
Picture 2-1: Safety System	19
Picture 2-2: Emergency Stop.....	20
Picture 2-3: Safety Switch.....	20
Picture 2-4: System Structure (SG-2417N).....	22
Picture 2-5: System Structure (SG-2427N).....	25
Picture 2-6: System Structure (SG-2436N).....	28
Picture 2-7: Cutting Chamber	31
Picture 2-8: Blade Rest.....	32
Picture 2-9: Feed Box, Feed Port and Material Stopper	33
Picture 2-10: Storage Bin.....	33
Picture 2-11: Main Body	34
Picture 2-12: Main Circuit (400V).....	35
Picture 2-13: Control Circuit 1(400V).....	36
Picture 2-14: Control Circuit 2 (400V).....	37
Picture 2-15: Electrical Components Layout (400V).....	38
Picture 2-16: Main Electrical Circuit (230V)	43
Picture 2-17: Control Circuit 1(230V).....	44
Picture 2-18: Control Circuit 2(230V).....	45
Picture 2-19: Electrical Components Layout (230V).....	46
Picture 2-20: Electrical Components Description.....	50
Picture 2-21: 30-second Instant Recycling System.....	51
Picture 2-22: Warning Light	51
Picture 2-23: Level Motor.....	52

Picture 2-24: Control Cabinet and Valve.....	52
Picture 3-1: Installation Notice	54
Picture 3-2: Installation Place	55
Picture 3-3: Installation of Bearing and Cutter Shaft 1	55
Picture 3-4: Installation of Bearing and Cutter Shaft 2	56
Picture 3-5: Installation of Bearing and Cutter Shaft 3	56
Picture 3-6: Installation of Teeth Cutter and Fixed Blade.....	56
Picture 3-7: Installation of Reduction Gear 1	57
Picture 3-8: Installation of Reduction Gear 2	58
Picture 3-9: Installation of Feed Box, Feed Port and Storage Bin 1.....	58
Picture 3-10: Installation of Feed Box, Feed Port and Storage Bin 2.....	58
Picture 3-11: Installation of Feed Box, Feed Port and Storage Box 3.....	59
Picture 3-12: Installation of Feed Box, Feed Port and Storage Box 4.....	59
Picture 3-13: Installation of Feed Box, Feed Port and Storage Box 5.....	59
Picture 4-1: Open the Feed Box	62
Picture 4-2: Main Power Switch	63
Picture 4-3: START, Emergency Stop and STOP Button	63
Picture 4-4: Motor Reversed Protection.....	64
Picture 6-1: Blades Maintenance	67
Picture 6-2: Dismantle Fixed Blades.....	68
Picture 6-3: Dismantle Rotate Blades	68
Picture 6-4: Star Screws	71
Picture 6-5: Machine Cleaning.....	72

1. General Description



Please read this manual carefully before using this machine in order to operate correctly against any damage caused due to improper operation.



Note!

Always take great care when the knives are within reach, they are very sharp and can cause personal injury.



Forbidden to process flammable or toxic material!

SG-24N series granulators operate in super low speed to cut materials into well-proportioned granules. There are least dusts produced in the cutting process. Multiple security devices ensure high safety grade; automatic reverse running function ensures continuous operation. This series of screenless granulators are suitable for granulating hard and thick materials.



Model: SG-2427N

1.1 Coding Principle

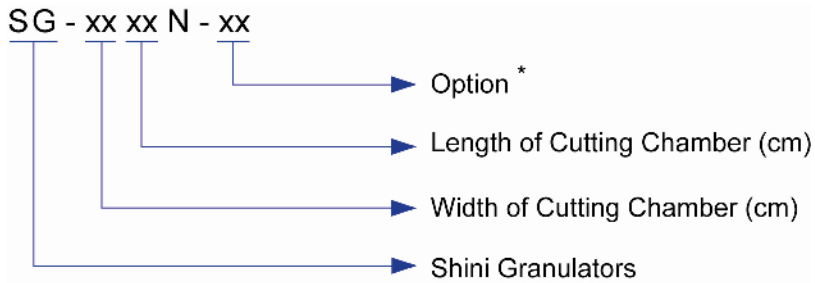

Note: *

VR=Loading by High Pressure Air BR=Loading by Bolwer
BC=Blower Conveying & Cyclone Dust Collector
DS=Dust Separator H=Higher Motor Power
R=For Stainless Steel Made Feed Port and Storage Tank

1.2 Feature

Standard configuration

- 1) SG-24N series German-made gear motor features steady performance, long service life and high torque.
- 2) SG-24N series teeth cutters and cutting blades are integrally fitted in one cutting chamber.
- 3) New-type inclined teeth cutter reduces the possibility of stress concentration, enhance bearing capacity and converts force direction so that cutter lifespan can be prolonged.
- 4) SG-24N series adopt moment arm flange to secure reduction gear, making running smooth with low noise.
- 5) When motor blockage occurs, the machine will alarm visibly and enable motor fo run reversely. It resumes normal operation automatically after the trouble is clear.
- 6) European type appearance, compact in size and easy to access for cleaning and maintenance.
- 7) Transparent PC feeding hopper.
- 8) Screenless design, well-proportioned size of regrinds and least amount of dusts. Regrinds could be used with virgin materials.

Accessory option

- 1) 30-second instant recycling system, regrind conveying via blower & cyclone, dust separator, manual storage bin and full-receiver alarm device.

All service work should be carried out by a person with technical training or corresponding professional experience. The manual contains instructions for both handling and servicing. Chapter 6, which contains service instructions intended for service engineers. Other chapters contain instructions for the daily operator.

Any modifications of the machine must be approved by SHINI in order to avoid personal injury and damage to machine. We shall not be liable for any damage caused by unauthorized change of the machine.

Our company provides excellent after-sales service. Should you have any problem during using the machine, please contact the company or the local vendor.

Headquarter and Taipei factory:

Tel: (886) 2 2680 9119

Shini Plastics Technologies (Dongguan), Inc:

Tel: (86) 769 8111 6600

Shini Plastics Technologies India Pvt.Ltd.:

Tel: (91) 250 3021 166

1.3 Technical Specifications

1.3.1 Technical Specifications

Table 1-1: Technical Specifications

Model	SG-2417N	SG-2427N	SG-2436N
Motor Power (kW, 50/60Hz)	0.75/0.45	0.75/0.45	1.5/1.75
Rotating Speed (r.p.m, 50/60Hz)	27/33	27/33	27/33
Material of Teeth Cutters	SKD11	SKD11	SKD11
Number of Cutting Blades	1	2	3
Number of Teeth Cutters	2	3	4
Number of Large Teeth Cutlers	/	/	/
Number of Small Teeth Cutlers	/	/	/
Cutting Chamber (mm)	240×175	240×270	240×365
Max. Throughput Capacity (kg/hr, 50/60Hz)	3.5	6	8.5
Noise Level dB(A)	80~85	80~85	80~85
30-Sec. Instant Recycling	○	○	○
Regrind Conveyor (BC Type)	○	○	○
Dust Separator	○	○	○
Level Detector	○	○	○
Proportional Valve	○	○	○
Manual Storage Bin	/	/	/
Dimensions			
H (mm)	1330	1330	1330
H1 (mm)	975	975	975
W (mm)	770	870	970
W1 (mm)	310	410	500
D (mm)	425	425	425
D1 (mm)	350	350	350
Weight (kg)	215	240	295

Note: 1) "○" optional.

- 2) For stainless steel made feed port and manual storage bin, plus "R" at model behind.
- 3) Max. Capacity of the machine is subject to the size and composition of the material.
- 4) Noise level will vary with different materials.
- 5) SKD-11 is material code number of Japanese JIS standard.
- 6) V-type balde is standard, dilated V-type blade is optional
- 7) For avoiding plastic to adhibit the blade, all materials should be crushed at normal temperature.
- 8) Power supply: 3Φ, 230 / 400 / 460 / 575VAC, 50 / 60Hz.

1.3.2 Dimensions

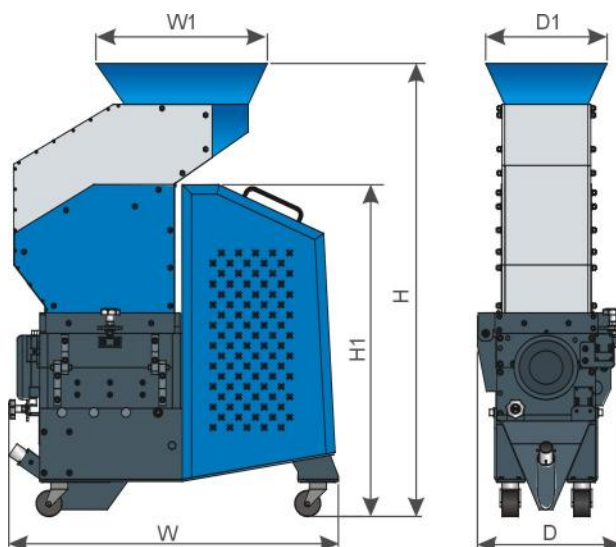

Picture 1-1: Dimensions

1.4 Safety Regulations

Follow the instructions in this manual to avoid personal injury and damage to machine components.

The following safety measures shall be followed when operating the granulator.

1.4.1 Safety Signs and Labels



Electrical installation must only be done by a competent electrician!



Before the granulator is opened for servicing and maintenance, always disconnect the power with both the main switch and the control switch on the granulator.



Never put any part of your body through the granulator openings, unless both the main switch and the control switch on the granulator are in "OFF" position.



High voltage! danger!

This sign is attached on the control box and the wiring box.



Be careful with the rotating knives, they are very sharp and can cause personal injury!



The granulator should not be started before the feed box and storage box are properly closed.



Attention please!

Ear protection is used during granulating of plastic materials.



Make sure the power has been cut off before open the feed box.







SG-24N Granulators cannot deal with fibre added material.









Attention!

No need for regular inspection because all the electrical parts in the control unit are fixed tightly!

When operate the granulator, please notice the following signs

	 Hazard High voltage ! May lead to casualty or other serious danger. Please cut off the power before repairing. Circuit diagram should only be changed by professionals. Grounding is necessary.
	 Warning Pinch risk when moving belt. Take out or open protective cover is not allowed when it is running.

	 Warning There is a pinch risk for this protective cover keep some distance away from that.
	 Warning The cutter are very sharp, can cause injury take out or open protective cover is not allowed when it is running. Keep some distance away from the cutters.
	 Notice Read the instruction manual carefully before operating. Before start, do the safety device test according to the instruction. It is not allowed to change the design of the machine unless it is approved from the manufacturer.

1.4.2 Transportation and Storage of the Machine

Transportation

- 1) SG-24N series of granulators are packed in plywood cases with wooden pallet at the bottom, suitable for quick positioning by fork lift.
- 2) After unpacked, castors equipped on the machine can be used for ease of movement.
- 3) Do not rotate the machine and avoid collision with other objects during transportation to prevent improper functioning.
- 4) The structure of the machine is well-balanced, although it should also be handled with care when lifting the machine for fear of falling down.
- 5) The machine and its attached parts can be kept at a temperature from -25°C to +55°C for long distance transportation and for a short distance, it can be transported with temperature under +70°C.

Storage

- 1) SG-24N series should be stored indoors with temperature kept from 5°C to 40°C and humidity below 80%.

- 2) Disconnect all power supply and turn off main switch and exigency stop switch.
- 3) Keep the whole machine, especially the electrical components away from water to avoid potential troubles caused by the water.
- 4) Use plastic film to cover the machine tightly to prevent the machine from dust and rains.

Working environment

The machine should be operated:

- 1) Indoors in a dry environment with max. temperature +45°C and humidity no more than 80%.

Do not use the machine:



- 1) If it is with a damaged cord.
- 2) On a wet floor or when it is exposed to rain to avoid electric shock.
- 3) If it has been dropped or damaged until it is checked or fixed by a qualified serviceman.
- 4) This equipment works normally in the environment with altitude over 3000m.
- 5) At least 1m surrounding space is requested when this equipment is running. Keep this equipment away from flammable sources at least two meters.
- 6) In the work area of vibration and strong magnetic force.

Rejected parts disposal

When the equipment has run out its life time and can not be used any more, unplug the power supply and dispose of it properly according to local code.



Fire hazard!

In case of fire, CO₂ dry powder fire extinguisher should be applied.



Flammable materials or materials which are contaminated by flammable substances/liquid may not be processed in the granulator. Serious risk of fire or explosion may cause personnel injury.



It is very important to tighten the screw as required torque.



When process item is longer than feed port, please cut long items into half until the length is shorter before processing.



Please don't put materials into the granulator if they are thinner than 2 mm and are soft and flexible, like rubber.

1.5 Exemption Clause

The following statements clarify the responsibilities and regulations born by any buyer or user who purchases products and accessories from Shini (including employees and agents).

Shini is exempted from liability for any costs, fees, claims and losses caused by reasons below:

1. Any careless or man-made installations, operation and maintenances upon machines without referring to the Manual prior to machine using.
2. Any incidents beyond human reasonable controls, which include man-made vicious or deliberate damages or abnormal power, and machine faults caused by irresistible natural disasters including fire, flood, storm and earthquake.
3. Any operational actions that are not authorized by Shini upon machine, including adding or replacing accessories, dismantling, delivering or repairing.
4. Employing consumables or oil media that are not appointed by Shini.

2. Structural Features and Working Principle

2.1 General Description

SG-24N series are belong to "by the press" granulator, which are designed for grinding different types of plastic waste. The granulator are controlled by main power switch, emergency stop button, start button, stop button and safety switches.

2.1.1 Working Principle

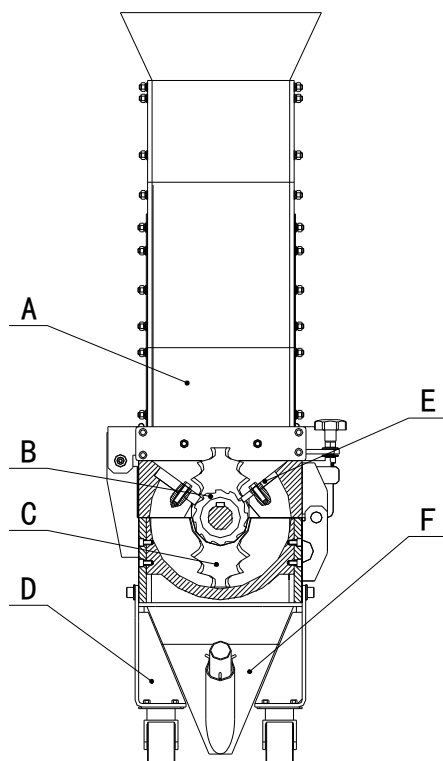

Parts name:

A. Feed box B. Teeth cutter C. Staggered blade D. Knife bed E. Fixed blade F. Storage bin

Picture 2 1: Working Principle

The material is fed in via a feed box (A) and falls down to the teeth cutters(B), the block material is cutted by the staggered (C) and fixed blades (E), then the material is cutted into granule by (B) and (E). The granule directly fall into the

storage bin (F), it does not need the screen. The cutting chamber is easy to open for cleaning and maintenance. After this, the granulate is ready for re-use in the production machine, or to be transported to a container for later use.

2.2 Safety System

To avoid accidental bodily injury during granulator running, a set of safety system has been designed. High-speed rotating cutter is located in the granulator and subject to accident. So safety system has been set up to protect bodily safety. In any cases, the safety system cannot be changed at random. Otherwise the machine will be under dangerous condition and subject to accident happening. The maintenance and preservation of safety system shall be done by professional staff. In case the safety system of granulator is changed, our company will not perform our commitment. The replacement of all spare parts will be done by SHINI Company.

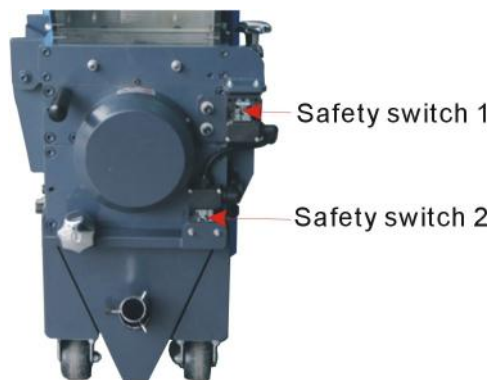

Picture 2-1: Safety System

2.2.1 Emergency Stop Switch

There is one red button on the control panel. Upon pushing it, the machine will stop running. Turn the button in the arrow direction as shown on the button, the button will reset (counter-clockwise).

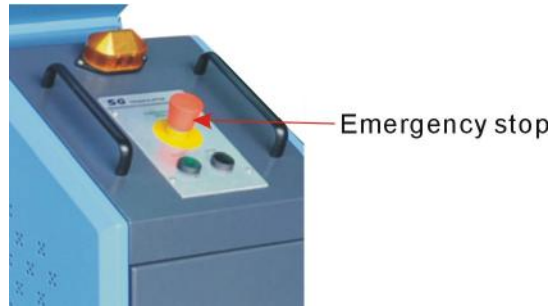

Picture 2-2: Emergency Stop

2.2.2 Safety Switch

On the granulator is equipped the safety position switch for circuit breaker. In case the position of feed box is changed or the breaker is loosened, it will cut off the power supply. There are two safety switches on the granulator: one is located between the feed box and the cutting chamber while the other one is between the storage bin and machine body.

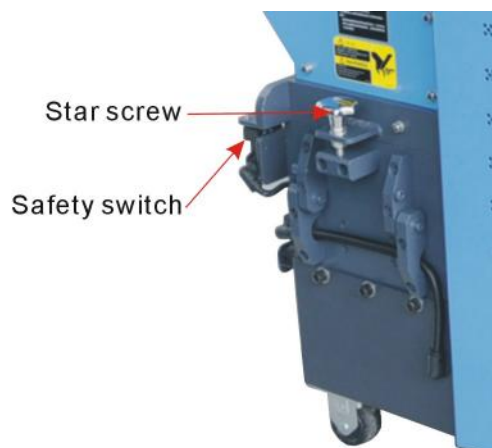

Picture 2-3: Safety Switch

2.2.3 Gate Lock

For opening feed box and cutting chamber, users need to loosen a long star screw (gate lock). It takes some time to unscrew the lock to completely stop cutter shaft and avoid personal injuries.

Notice before startup:

- 1) Check if feed box is tightened.
- 2) Check if plug of storage bin safety switch is tightened.
- 3) Check if there are foreign matters like metals in the cutting chamber.

2.3 Assembly Drawing

2.3.1 System Structure (SG-2417N)

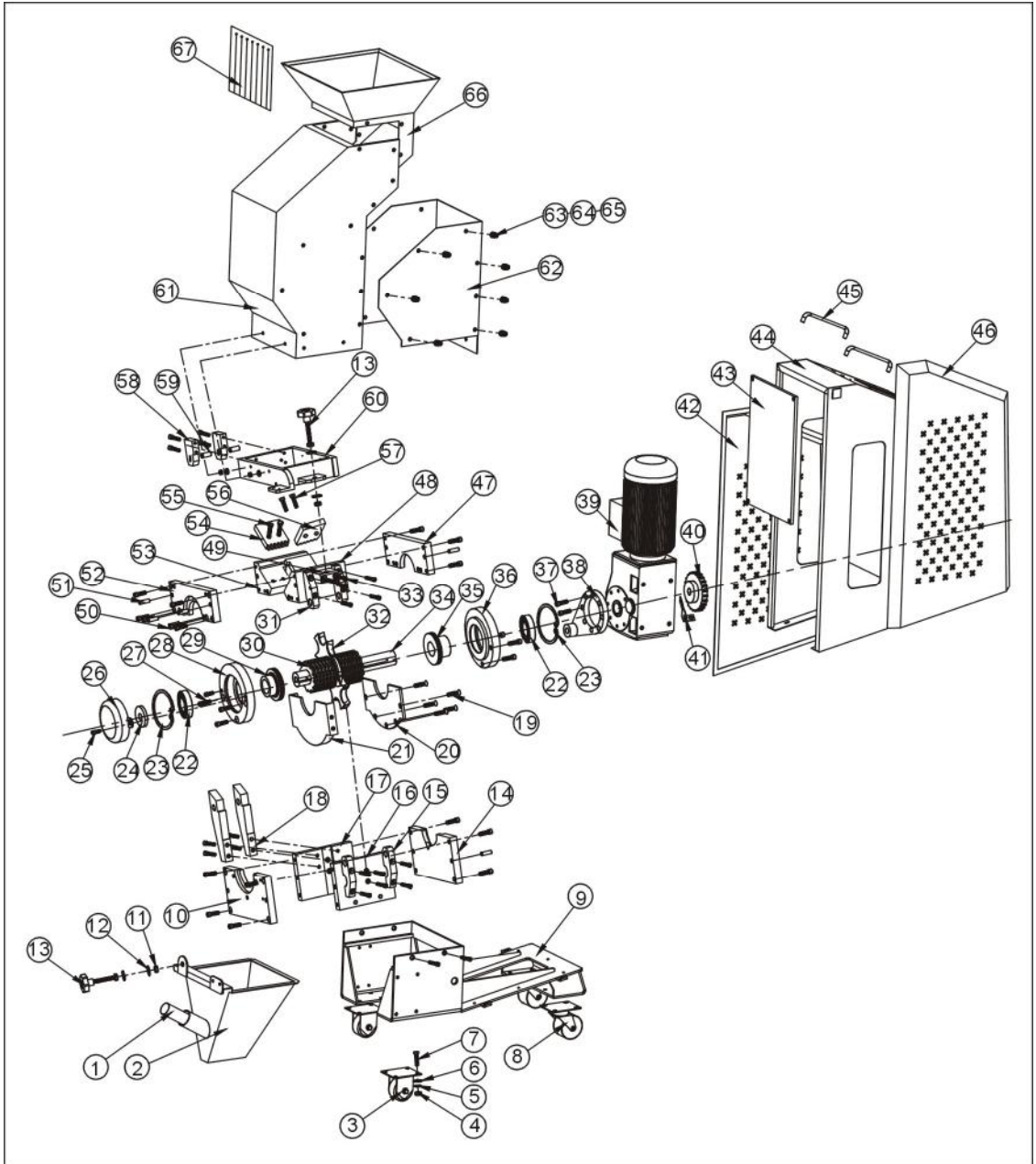

Note: Please refer to 2.3.2 material list about the parts code.

Picture 2-4: System Structure (SG-2417N)

2.3.2 Parts List (SG-2417N)

Table 2-1: Parts List (SG-2417N)

No.	Name	Part No.	No.	Name	Part No.
1	Suction pipe	-	27	Socket head cap screw M12×25	YW61122500000
2	Storage bin	-	28	Left bearing base	BW30024001010
3	Fixing black rubber wheel 3"	YW03000300300	29	Left shaft sleeve	BW30024000210
4	Hexnut M8	YW64080600000	30	Teeth cutter R *	YW40024000400
5	Spring washer 8	YW65008000200		Narrow teeth cutter R *	YW40241400000
6	Flat washer 8	YW66081600000		Widened teeth cutter R*	YW40241000000
7	Hexagon bolt M8×25	YW60082500300	31	Turning block 1	BH10240900110
8	Brake black rubber wheel 3"	YW03000300000	32	Staggered blade*	BW40240500010
9	Base	-	33	Socket head cap screw M10×60	YW61106000000
10	Left bearing holder at bottom	BH10241100110	34	Main shaft	BH56242701010
11	Anti-loose hexnut M12	YW64012100000	35	Right shaft sleeve	BH10240400010
12	Washer Φ12×24	YW66122400000	36	Right bearing base	BW30240800010
13	Plum blossom assembly	BH56240200010	37	Socket head cap screw M8×20	YW61082000200
14	Right bearing holder at bottom	BH10241200410	38	Gear motor fixed plate	BH10241900110
15	Rotate block of chamber 2	BH10240900210	39	Reduction gear	YM50007500000
16	Front case block at bottom	BH10241702010	40	Inductive wheel	BH11002401010
17	Back case block at bottom	BH10241703010	41	Inductive wheel fixed plate	-
18	Rotate block of feed box 2	BH10241200110	42	Right guardplate	-
19	Flat inner hex bolt M8X20	YW61082000100	43	Front guardplate	-
20	Middle plate 2	BH10002400910	44	Control cabinet	-
21	Middle plate 1	BH10002400710	45	Handle LS516-175	YW06516000000
22	Bearing 6213 DDU/VV	YW11621300000	46	Left guardplate	-
23	Spring ring 120	YW69012700000	47	Right bearing holder at top	BH10240000210
24	Washer	-	48	Front case block at top	BW30241700110
25	Socket head cap screw M12×20	YW61122000000	49	Feed box lcking block	-
26	Bearing cap	-	50	Socket head cap screw M10×30	YW61103000100

No.	Name	Part No.	No.	Name	Part No.
51	Spring round pin 12×35	YW69123500000	58	Turning block 1	BH10241300110
52	Left bearing holder at top	BH10240000310	59	Feed box spindle	BH10184900010
53	Back case block at top	BW30241700010	60	Feed box base	
54	Fixed front blade F1*	YW40024000100	61	Feed box	YR90241700900
	Narrow fixed front blade F1*	BW40041100010	62	Feed box front plate	
	Widened fixed front blade F1*	YW40240700000	63	Cup head socket headcap screw M8×25	YW61082500200
55	Hexagon headed bolt M10×35	YW60103500200	64	Flat washer 8	YW66081600000
56	Fixed rear blade B*	YW40024000300	65	Antiloose hexnut M8	YW64000800100
	Narrow fixed rear blade B*	BW40131100010	66	Feed port	
	Widened fixed rear blade B*	YW40240900000	67	Material stopper	YR90152000000
57	Hexagon headed bolt M10×30	YW60103000200			

* means possible broken parts.

** means easy broken part. and spare backup is suggested.

Please confirm the version of manual before placing the purchase order to guarantee that the item number of the spare part is in accordance with the real object.

2.3.3 System Structure (SG-2427N)

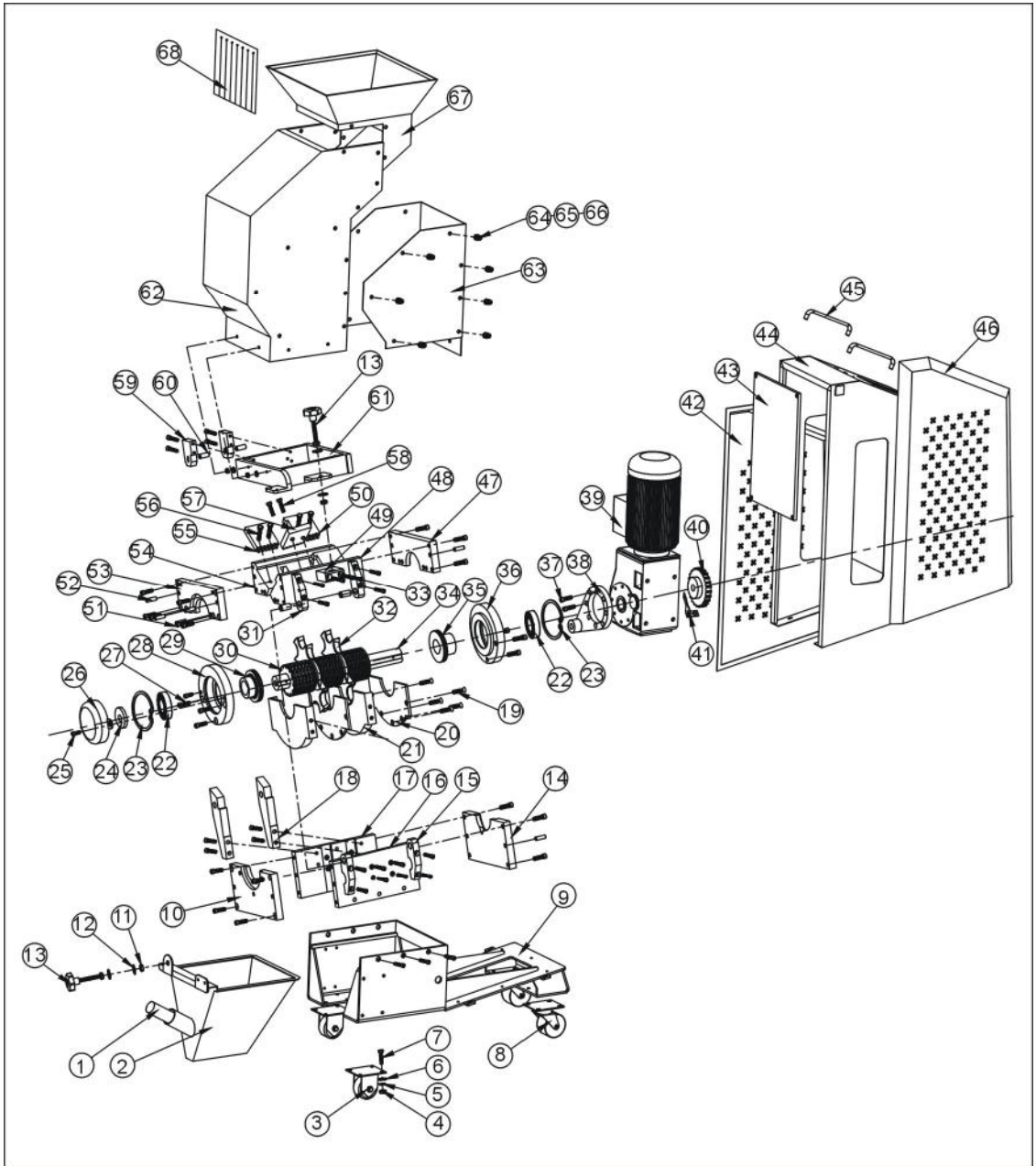

Note: Please refer to 2.3.4 material list about the parts code.

Picture 2-5: System Structure (SG-2427N)

2.3.4 Parts List (SG-2427N)

Table 2-2: Parts List (SG-2427N)

No.	Name	Part No.	No.	Name	Part No.
1	Suction pipe	-	26	Bearing cap	-
2	Storage bin	-	27	Socket head cap screw M12×X25	YW61122500000
3	Fixed black rubber wheel 3"	YW03000300300	28	Left bearing base	BW30024001010
4	Hexnut M8	YW64080600000	29	Left shaft sleeve	BW30024000210
5	Spring washer 8	YW65008000200	30	Teeth cutter R *	YW40024000400
6	Flat washer 8	YW66081600000		Narrow teeth cutter R *	YW40241400000
7	Socket head cap screw M8×25	YW60082500300		Widened teeth cutter R *	YW40241000000
8	Brake black rubber wheel 3"	YW03000300000	31	Turning block of cutting chamber 1	BH10240900110
9	Base	-	32	Staggered blade*	BW40240500010
10	Left bearing holder at bottom	BH10241100110	33	Socket head cap screw M10×60	YW61106000000
11	Antiloose hexnut M12	YW64012100000	34	Main shaft	BH56242701010
12	Washer Φ12×24	YW66122400000	35	Right shaft sleeve	BH10240400010
13	Star assembly	BH56240200010	36	Right bearing base	BW30240800010
14	Right bearing holder at bottom	BH10241200410	37	Socket head cap screw M8×20	YW61082000200
15	Turning block 2	BH10240900210	38	Gear motor fixed plate	BH10241900110
16	Front case block at bottom	BH10242702010	39	Gear motor	YM50007500000
17	Back case block at bottom	BH10242703010	40	Inductive wheel	BH11002401010
18	Turning block of feed box 2	BH10241200110	41	Sensor fixed plate	-
19	Pan head socket headcap screw M8×20	YW61082000100	42	Right guardplate	-
20	Middle plate 2	BH10002400910	43	Front guardplate	-
21	Middle plate 1	BH10002400710	44	Control cabinet	-
22	Bearing 6213 DDU/VV	YW11621300000	45	Handle LS516-175	YW06516000000
23	Spring ring 120	YW69012700000	46	Left guardplate	-
24	Washer	-	47	Right bearing holder at top	BH10240000210
25	Socket head cap screw M12×20	YW61122000000	48	Front bearing holder at top	BW30242700510

No.	Name	Part No.	No.	Name	Part No.
49	Feed box locking block	-		Fixed rear blade B*	YW40024000300
50	Fixed front blade F2*	-	57	Narrow fixed rear blade B*	BW40131100010
	Narrow fixed fixed front blade F2*	-		Widened fixed rear blade B*	YW40240900000
	Widened fixed front blade F2*	-	58	Socket head cap screw M10×30	YW60103000200
51	Socket head cap screw M10×30	YW61103000100	59	Turning block of feed box 1	BH10241300110
52	Spring round pin 12×35	YW69123500000	60	Spindle of feed box	BH10184900010
53	Left bearing holder at top	BH10240000310	61	Feed box base	-
54	Back case block at top	BW30242700410	62	Feed box	YR90242700900
55	Fixed front blade F1*	YW40024000100	63	Feed box front plate	-
	Narrow fixed front blade F1*	BW40041100010	64	Cup head socket headcap screw M8×25	YW61082500200
	Widened fixed front blade F1*	YW40240700000	65	Flat washer 8	YW66081600000
56	Sockethead cap screw M10×35	YW60103500200			

* means possible broken parts.

** means easy broken part. and spare backup is suggested.

Please confirm the version of manual before placing the purchase order to guarantee that the item number of the spare part is in accordance with the real object.

2.3.5 System Structure (SG-2436N)

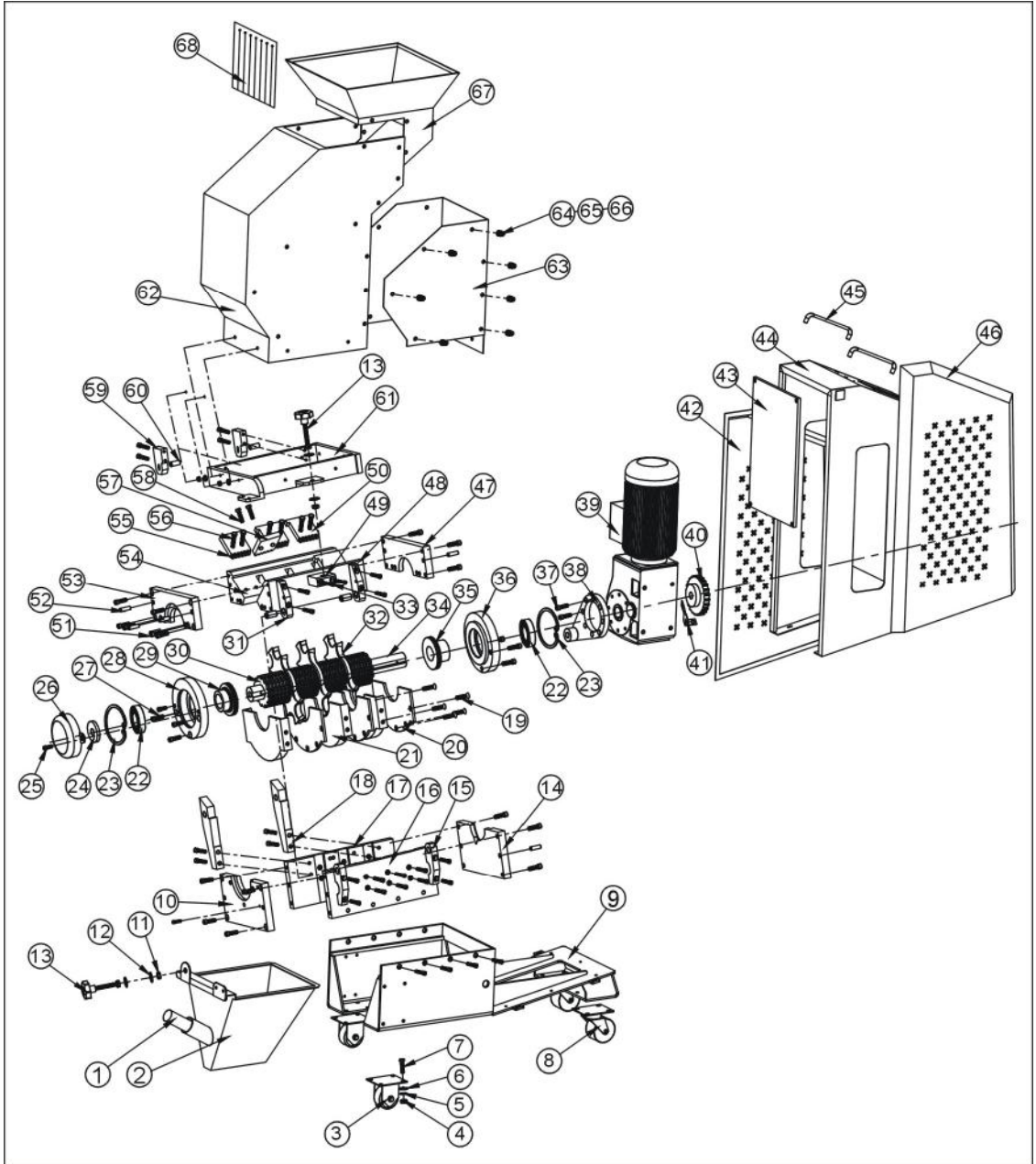

Note: Please refer to 2.3.6 material list about the parts code.

Picture 2-6: System Structure (SG-2436N)

2.3.6 Parts List (SG-2436N)

Table 2-3: Parts List (SG-2436N)

No.	Name	Part No.	No.	Name	Part No.
1	Suction pipe	-	26	Bearing cap	-
2	Storage bin	-	27	Socket head cap screw M12×25	YW61122500000
3	Fixed Black rubber wheel 3"	YW03000300300	28	Left bearing base	BW30024001010
4	Hexnut M8	YW64080600000	29	Left shaft sleeve	BW30024000210
5	Spring washer 8	YW65008000200	30	Teeth cutter R *	YW40024000400
6	Flat washer 8	YW66081600000		Narrow teeth cutter R*	YW40241400000
7	Socket head cap screw M8×25	YW60082500300		Widened teeth cutter R*	YW40241000000
8	Brake rubber wheel 3"	YW03000300000	31	Turning block of cutting chamber 1	BH10240900110
9	Base	-	32	Staggered blade*	BW40240500010
10	Left bearing hlder at bottom	BH10241100110	33	Socket head cap screw M10×60	YW61106000000
11	Antiloose hexnut M12	YW64012100000	34	Main shaft	BH56243601010
12	Washer Φ12 × 24	YW66122400000	35	Right shaft sleeve	BH10240400010
13	Star assembly	BH56240200010	36	Right bearing base	BW30240800010
14	Right bearing holder at bottom	BH10241200410	37	Socket head cap screw M8×20	YW61082000200
15	Turning block of cutting chamber 2	BH10240900210	38	Gear motor fixed plate	BH10241900110
16	Front case block at bottom	BH10243602010	39	Gear motor	YM50001500000
17	Back case block at bottom	BH10243603110	40	Inductive wheel	BH11002401010
18	Turning block of feed box 2	BH10241200110	41	Sensor fixed plate	-
19	Pan head socket headcap screw M8×20	YW61082000100	42	Right guardplate	-
20	Middle plate 2	BH10002400910	43	Front guardplate	-
21	Middle plate 1	BH10002400710	44	Control cabinet	-
22	Bearing 6213 DDU/VV	YW11621300000	45	Handle LS516-175	YW06516000000
23	Spring ring 120	YW69012700000	46	Left guardplate	-
24	Washer	-	47	Right bearing holder at top	BH10240000210
25	Socket head cap screw M12×20	YW61122000000	48	Front case block at top	BW30243600610

No.	Name	Part No.	No.	Name	Part No.
49	Feed box locking block	-	58	Socket head cap screw M10×30	YW60103000200
50	Fixed front blade F2*	-	59	Turning block of feed box 1	BH10241300110
	Narrow fixed front blade F2*	-	60	Spindle of feed box	BH10184900010
	Widened fixed front blade F2*	-	61	Feed box base	-
51	Socket head cap screw M10X30	YW61103000100	62	Feed box	YR90243600900
52	Spring round pin 12×35	YW69123500000	63	Front plate of feed box	-
53	Left bearing holder at top	BH10240000310	64	Cup head socket head cap screw M8×25	YW61082500200
54	Back case block at top	BW30243600710	65	Flat washer 8	YW66081600000
55	Fixed front blade F1*	YW40024000100	66	Antiloose hexnut M8	YW64000800100
	Narrow fixed front blade F1*	BW40041100010	67	Feed port	
	Widened fixed front blade F1*	YW40240700000	68	Material stopper	YR90152000000
56	Socket head cap screw M10×35	YW60103500200			
57	Fixed rear blade B*	YW40024000300			
	Narrow fixed rear blade B*	BW40131100010			
	Widened fixed rear blade B*	YW40240900000			

* means possible broken parts.

** means easy broken part. and spare backup is suggested.

Please confirm the version of manual before placing the purchase order to guarantee that the item number of the spare part is in accordance with the real object.

2.3.7 Cutting Chamber

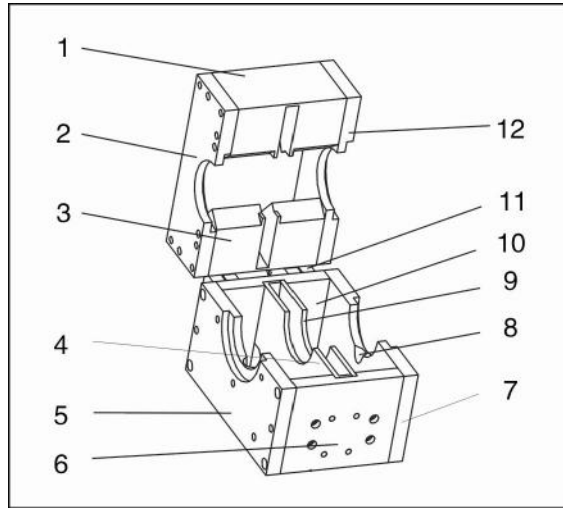

Picture 2-7: Cutting Chamber

2.3.8 Cutting Chamber Parts List

Table 2-4: Parts List

No.	Name	Quantity		
		SG-2417N	SG-2427N	SG-2436N
1	Front case block at top	1	1	1
2	Left bearing holder at top	1	1	1
3	Back case block at top	1	1	1
4	Middle plate 1	1	2	3
5	Left bearing holder at bottom	1	1	1
6	Front case block at bottom	1	1	1
7	Right bearing holder at bottom	1	1	1
8	Middle plate 2	1	2	3
9	Back case block at bottom	1	1	1
10	Locating block	1	1	1
11	Right bearing holder at top	1	1	1

2.3.9 Blade Rest

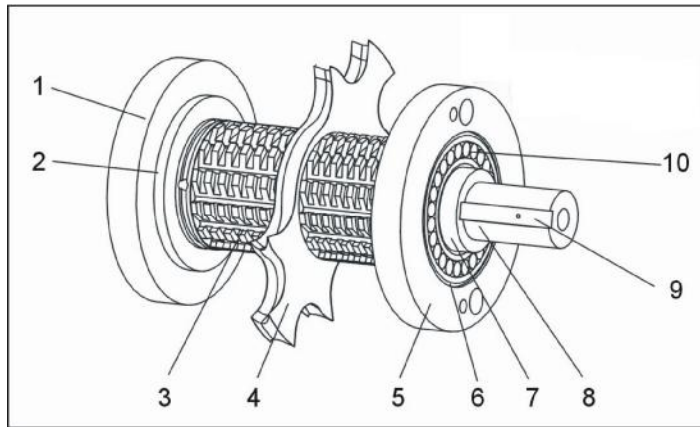

Picture 2-8: Blade Rest

2.3.9.1 Blade Rest Parts List

Table 2-5: Blades Rest Parts List

No.	Name	Quantity		
		SG-2417N	SG-2427N	SG-2436N
1	Left bearing block	1	1	1
2	Left shaft sleeve	1	1	1
3	Teeth cutter	2	3	4
4	Staggered blade	1	2	3
5	Right bearing block	1	1	1
6	Spring clip	2	2	2
7	Right shaft sleeve	1	1	1
8	Main shaft	1	1	1
9	Key	1	1	1
10	Bearing	2	2	2

2.3.10 Feed Box, Feed Port and Material Stopper

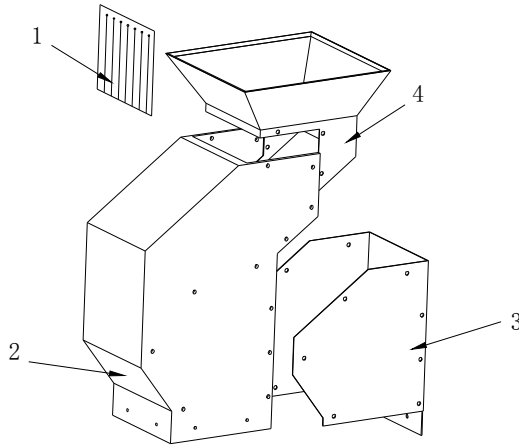

Picture 2-9: Feed Box, Feed Port and Material Stopper

2.3.11 Feed Box, Feed Port and Material Stopper Parts List

Table 2-6: Feed Box, Feed Port and Material Stopper Parts List

No.	Name	Quantity		
		SG-2417N	SG-2427N	SG-2436N
1	Material stopper	1	1	1
2	Feed box	1	1	1
3	Feed box front plate	1	1	1
4	Feed port	1	1	1

2.3.12 Storage Bin

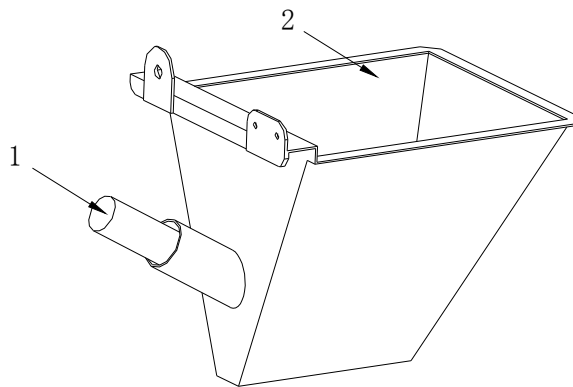

Picture 2-10: Storage Bin

2.3.13 Storage Bin Parts List

Table 2-7: Storage Bin Parts List

No.	Name	Quantity		
		SG-2417N	SG-2427N	SG-2436N
1	Suction tube	1	1	1
2	Storage bin	1	1	1

2.3.14 Main Body

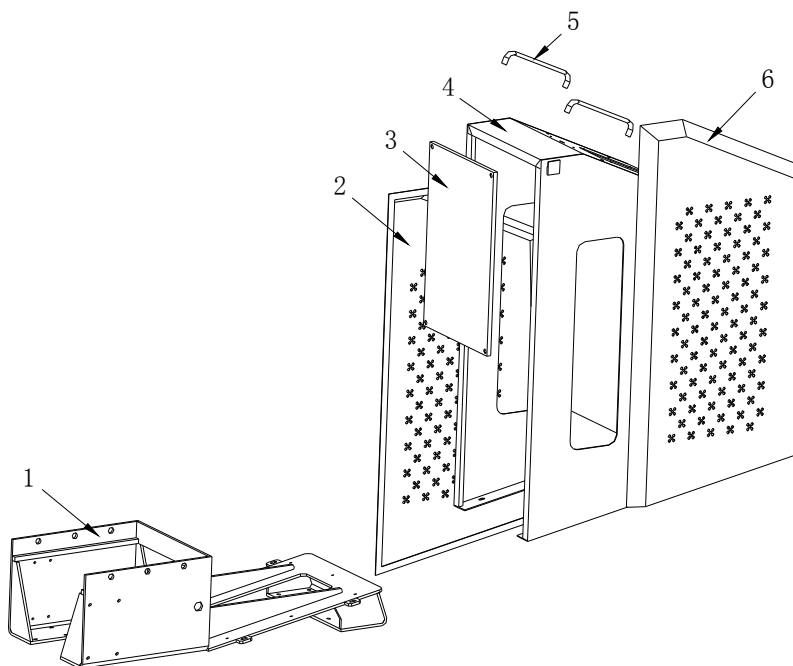

Picture 2-11: Main Body

2.3.15 Main Body Parts List

Table 2-8: Main Body Parts List

No.	Name	Quantity		
		SG-2417N	SG-2427N	SG-2436N
1	Base	1	1	1
2	Right backplate	1	1	1
3	Front backplate	1	1	1
4	Control cabinet	1	1	1
5	Handle LS516-175	2	2	2
6	Left backplate	1	1	1

2.4 Electrical Diagram

2.4.1 Main Circuit (400V)

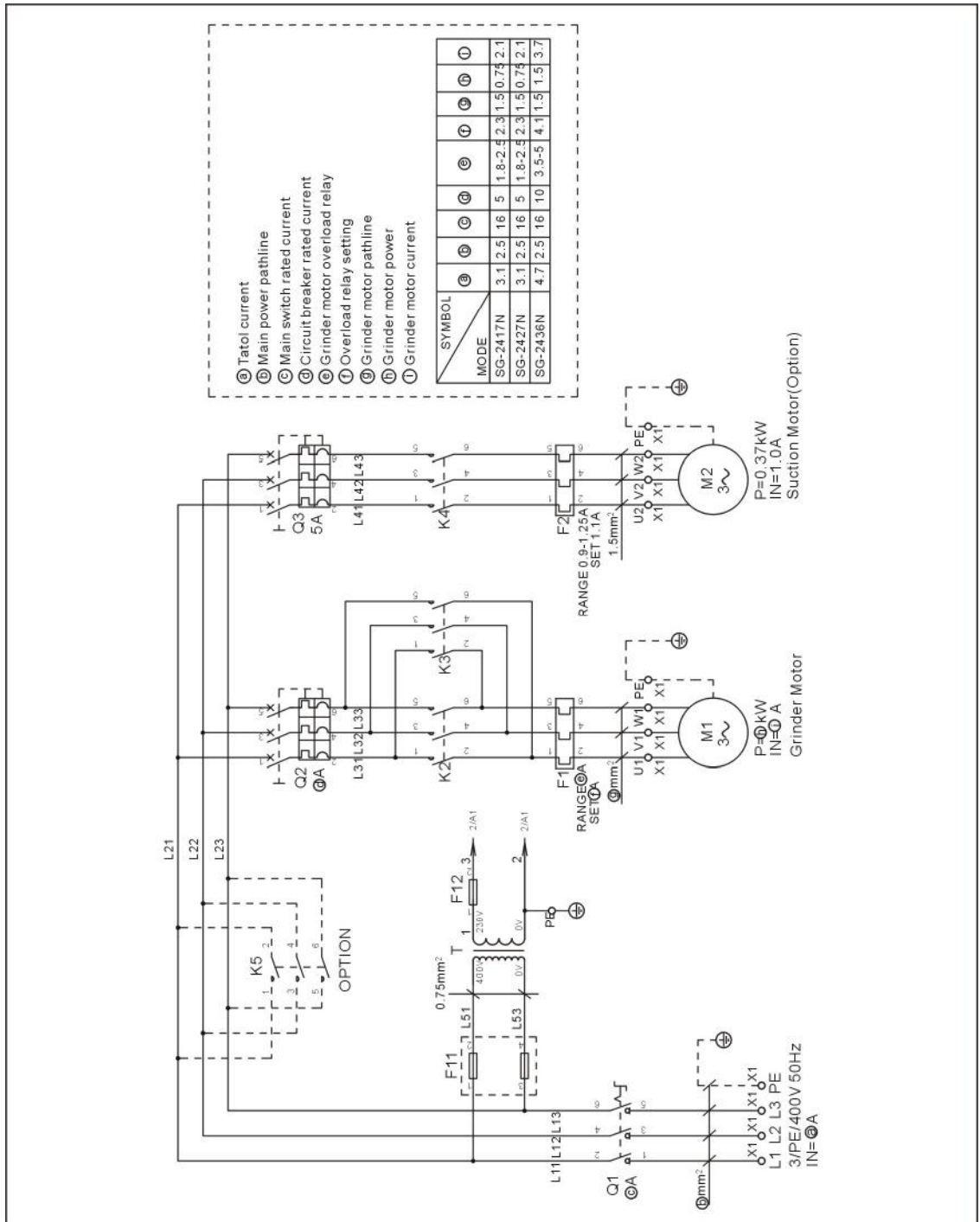

Picture 2-12: Main Circuit (400V)

2.4.2 Control Circuit (400V)

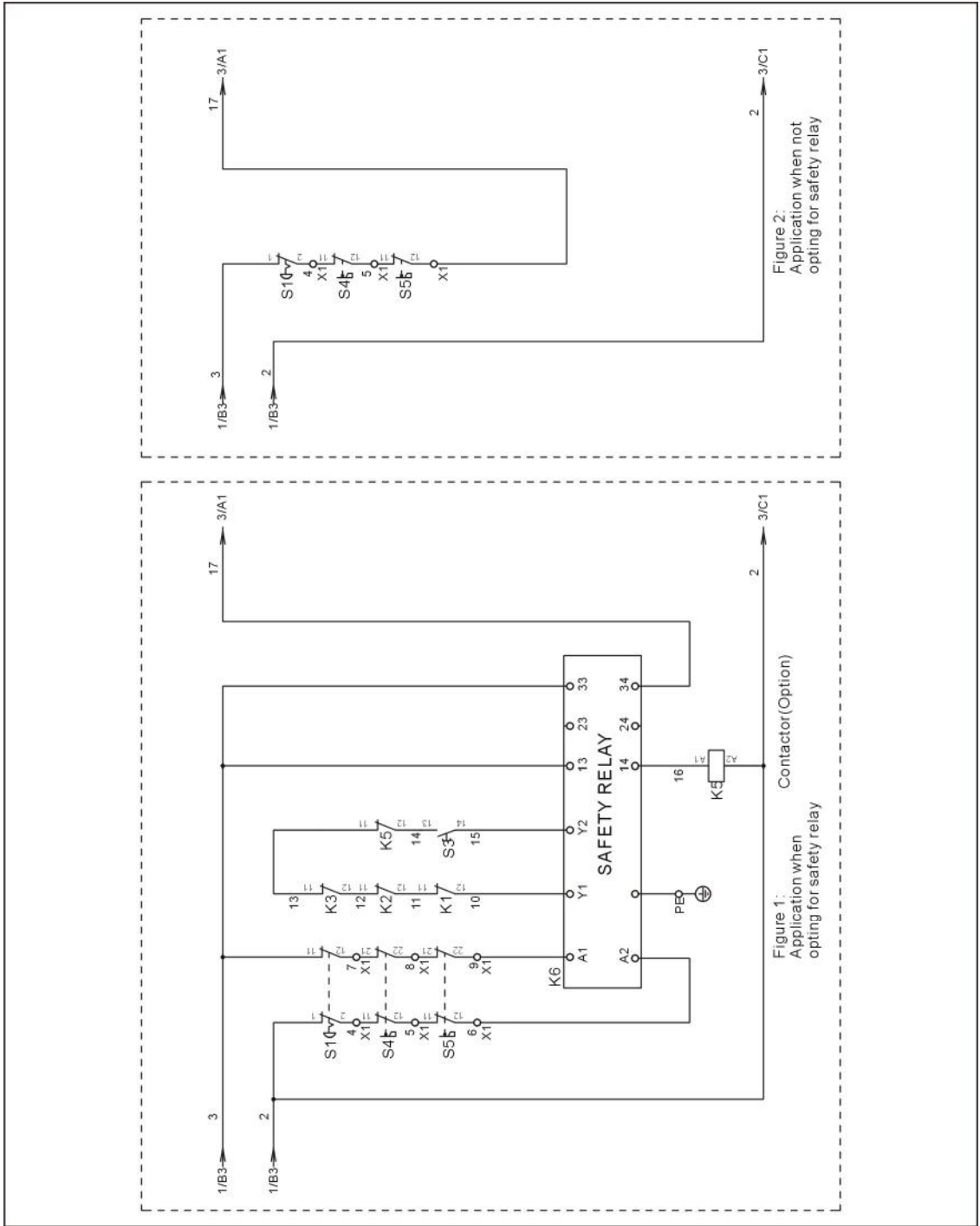

Picture 2-13: Control Circuit 1(400V)

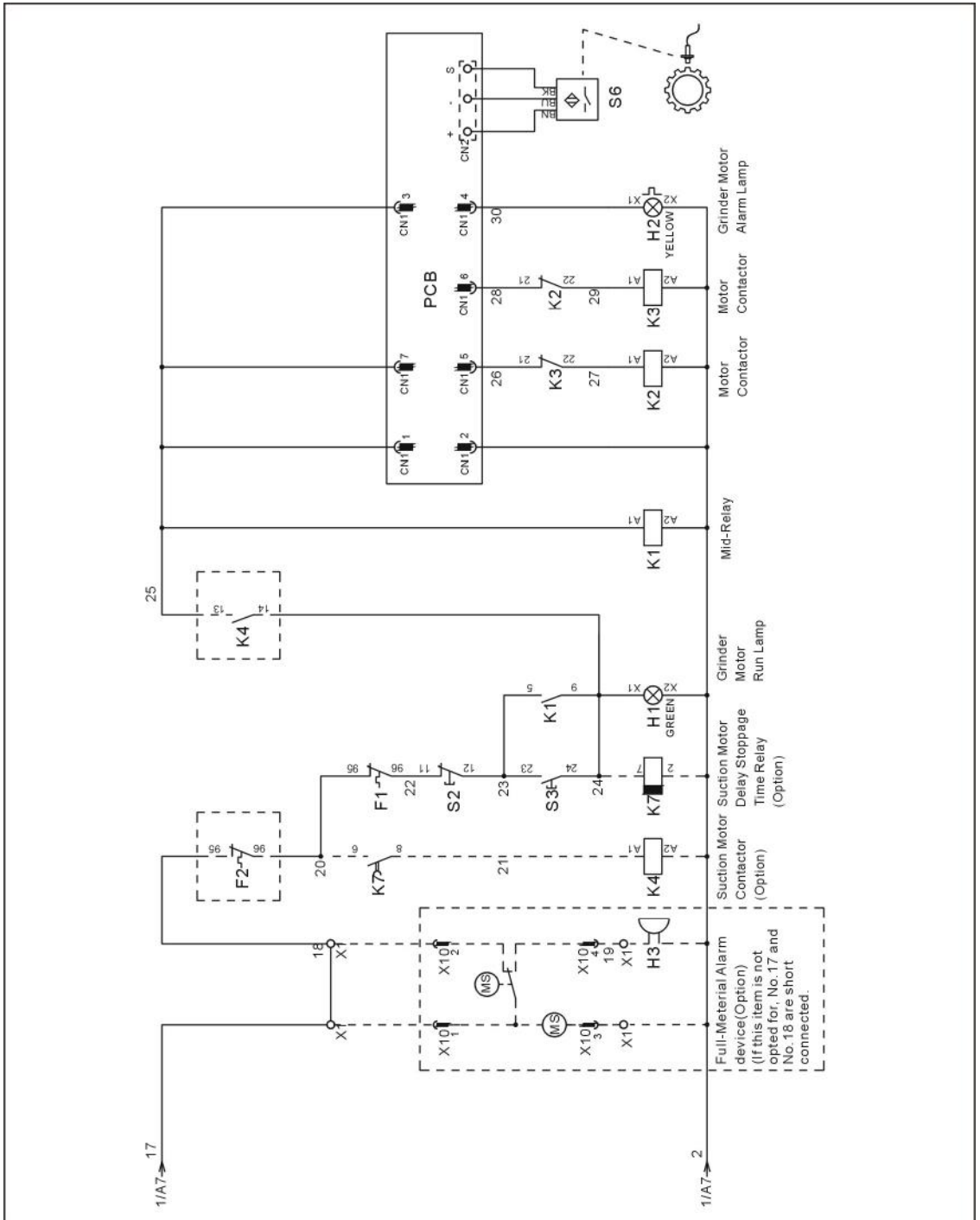

Picture 2-14: Control Circuit 2 (400V)

2.4.3 Electrical Components Layout (400V)

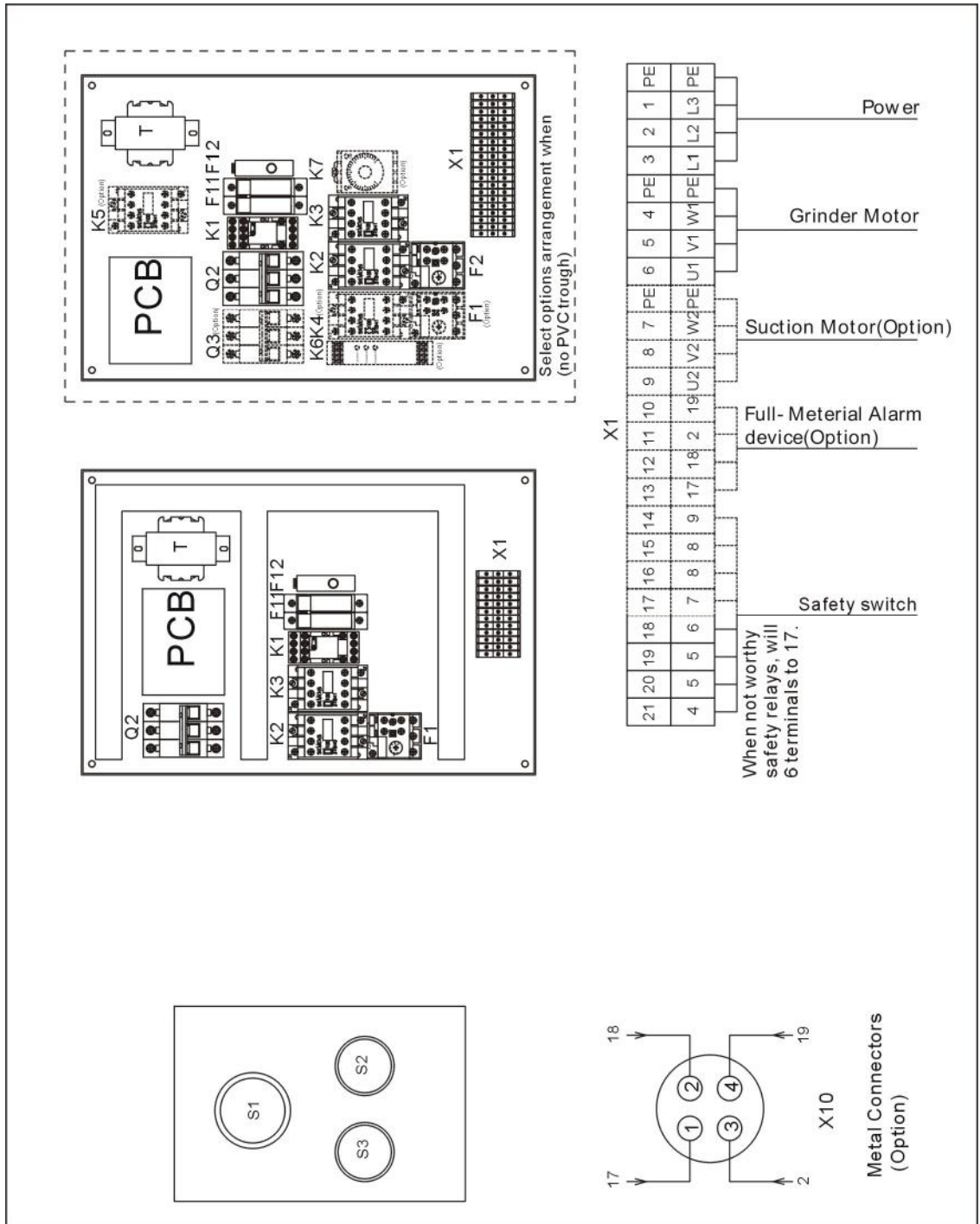

Picture 2-15: Electrical Components Layout (400V)

2.4.4 Electrical Components List (400V)

Table 2-9: SG-2417N/2427N Parts List (400V)

No.	Symbol	Name	Specification	Part No.
1	Q1	Power switch	16A	YE10200300000
2	Q2	Breaker*	5A	YE40603000000
3	Q3	Breaker*	5A	YE40603000000
4	K1	Auxiliary relay*	220V 50/60Hz	YE03270700000
5	K2,K3	Contactor*	220V 50/60Hz	YE00601522000
6	-	Auxiliary contact	1NC	YE00592110100
7	K4	Contactor*	220V 50/60Hz	YE00601521000
8	K5	Contactor*	220V 50/60Hz	YE00601522000
9	K6	Safety relay	220VAC	YE04372100000
10	K7	Time relay*	220V 50/60Hz	YE86322000000
11	F1	Thermal overload relay*	1.8~2.5A	YE01160180000
12	F2	Thermal overload relay*	0.9~1.25A	YE01160900000
13	T	Transformer*	IN=400V OUT=230V 300mA	YE70402300700
14	F11	Fuse**	2P	YE41032200000
15	-	Fuse core	1A	YE46001000100
16	F12	Fuse**	2A	YE41001000000
17	H2	Warning light	220V 50/60Hz	YE83305100200
18	H3	Buzzer	220VAC	YE84222000000
19	S1	Emergency stop	400VAC12 10A	YE11320300000
20	-	Contact block	1NC	YE19340000100
21	S2	STOP button	400VAC12 10A	YE11375800000
22	S3,H1	START button	400VAC12 10A	YE11325300000
23	-	Contact block	1NO	YE19340000000
24	S4,S5	Safety switch	AZ-15	YE16147600100
25	S4,S5	Safety switch	AZ-16	YE16147600000
26	PCB	PCB*	230VAC	YE80012200200
27	S6	Sensor*	24VDC NPN	YE15122400000
28	MS	Level switch*	3A/250V	YE15000200100
29	X1	Terminal board	32A	YE61250040000
30	-	-	-	YE61253500000
31	-	-	32A	YE61250040000
32	-	-	-	YE61253500000
33	-	-	32A	YE61250040000

No.	Symbol	Name	Specification	Part No.
34	-	-	32A	YE61250040000
35	X10	Metal joint	4P	YE68025400000
36	-	-	4P	YE68025400100
37	M1	Grinder motor	400V 50Hz 0.75kW	-
38	M2	Feeding blower	400V 50Hz 0.37kW	-

* means possible broken parts.

** means easy broken part. and spare backup is suggested.

Please confirm the version of manual before placing the purchase order to guarantee that the item number of the spare part is in accordance with the real object.

Table 2-10: SG-2436N PartsList (400V)

No.	Symbol	Name	Specification	Part No.
1	Q1	Power switch	16A	YE10200300000
2	Q2	Breaker*	5A	YE40603000000
3	Q3	Breaker*	5A	YE40603000000
4	K1	Auxiliary relay*	220V 50/60Hz	YE03270700000
5	K2,K3	Contactoer*	220V 50/60Hz	YE00601522000
6	-	Auxiliary contact	1NC	YE00592110100
7	K4	Contactoer*	220V 50/60Hz	YE00601521000
8	K5	Contactoer*	220V 50/60Hz	YE00601522000
9	K6	Safety relay	220VAC	YE04372100000
10	K7	Time relay*	220V 50/60Hz	YE86322000000
11	F1	Thermal overload relay*	3.5~5A	YE01160350000
12	F2	Thermal overload relay*	0.9~1.25A	YE01160900000
13	T	Transformer*	IN=400V OUT=230V 300mA	YE70402300700
14	F11	Fuse**	2P	YE41032200000
15	-	Fuse core	1A	YE46001000100
16	F12	Fuse**	2A	YE41001000000
17	H2	Warning light	220V 50/60Hz	YE83305100200
18	H3	Buzzer	220VAC	YE84222000000
19	S1	Emergency stop	400VAC12 10A	YE11320300000
20	-	Contact block	1NC	YE19340000100
21	S2	STOP button	400VAC12 10A	YE11375800000
22	S3,H1	START button	400VAC12 10A	YE11325300000
23	-	Contact block	1NO	YE19340000000
24	S4,S5	Safety switch	AZ-15	YE16147600100
25	S4,S5	Safety switch	AZ-16	YE16147600000
26	PCB	PCB*	230VAC	YE80012200200
27	S6	Sensor*	24VDC NPN	YE15122400000
28	MS	Level switch*	3A/250V	YE15000200100
29	X1	Terminal board	32A	YE61250040000
30	-	-	-	YE61253500000
31	-	-	32A	YE61250040000
32	-	-	-	YE61253500000
33	-	-	32A	YE61250040000
34	-	-	32A	YE61250040000
35	X10	Metal joint	4P	YE68025400000

No.	Symbol	Name	Specification	Part No.
36	-	-	4P	YE68025400100
37	M1	Grinder motor	400V 50Hz 1.5kW	-
38	M2	Feeding blower	400V 50Hz 0.37kW	-

* means possible broken parts.

** means easy broken part. and spare backup is suggested.

Please confirm the version of manual before placing the purchase order to guarantee that the item number of the spare part is in accordance with the real object.

2.4.5 Main Electrical Circuit (230V)

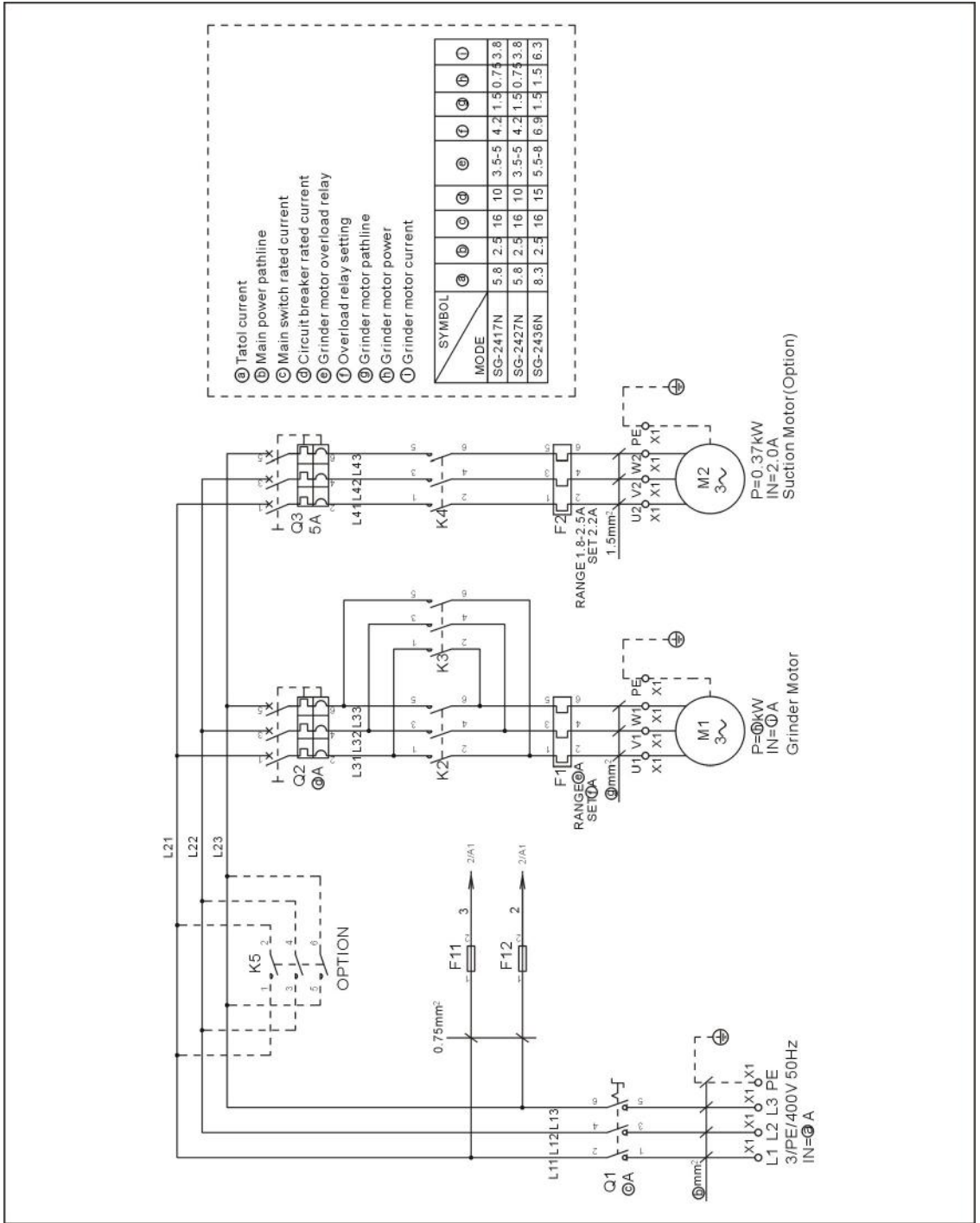

Picture 2-16: Main Electrical Circuit (230V)

2.4.6 Control Circuit (230V)

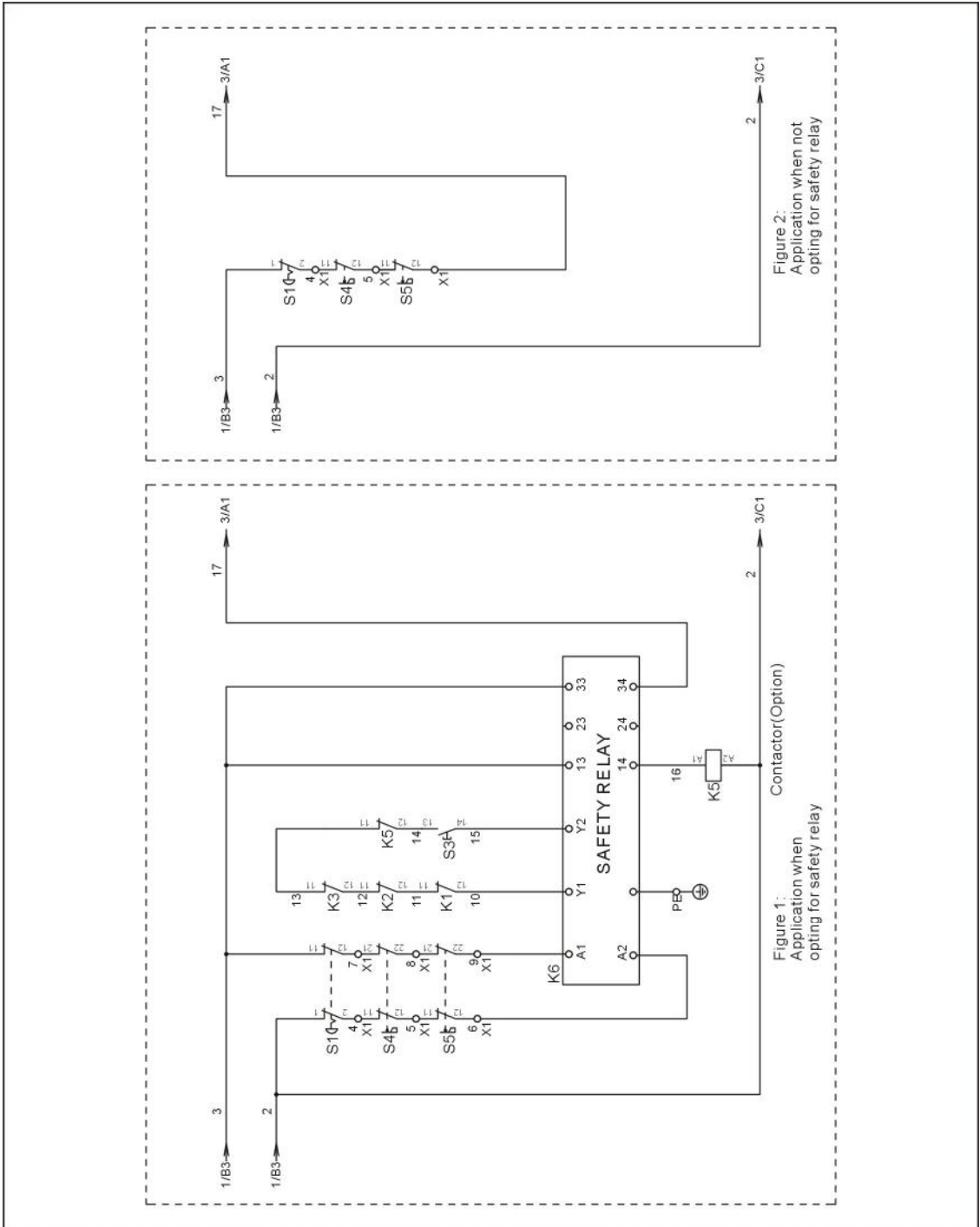

Picture 2-17: Control Circuit 1(230V)

2.4.7 Electrical Components Layout (230V)

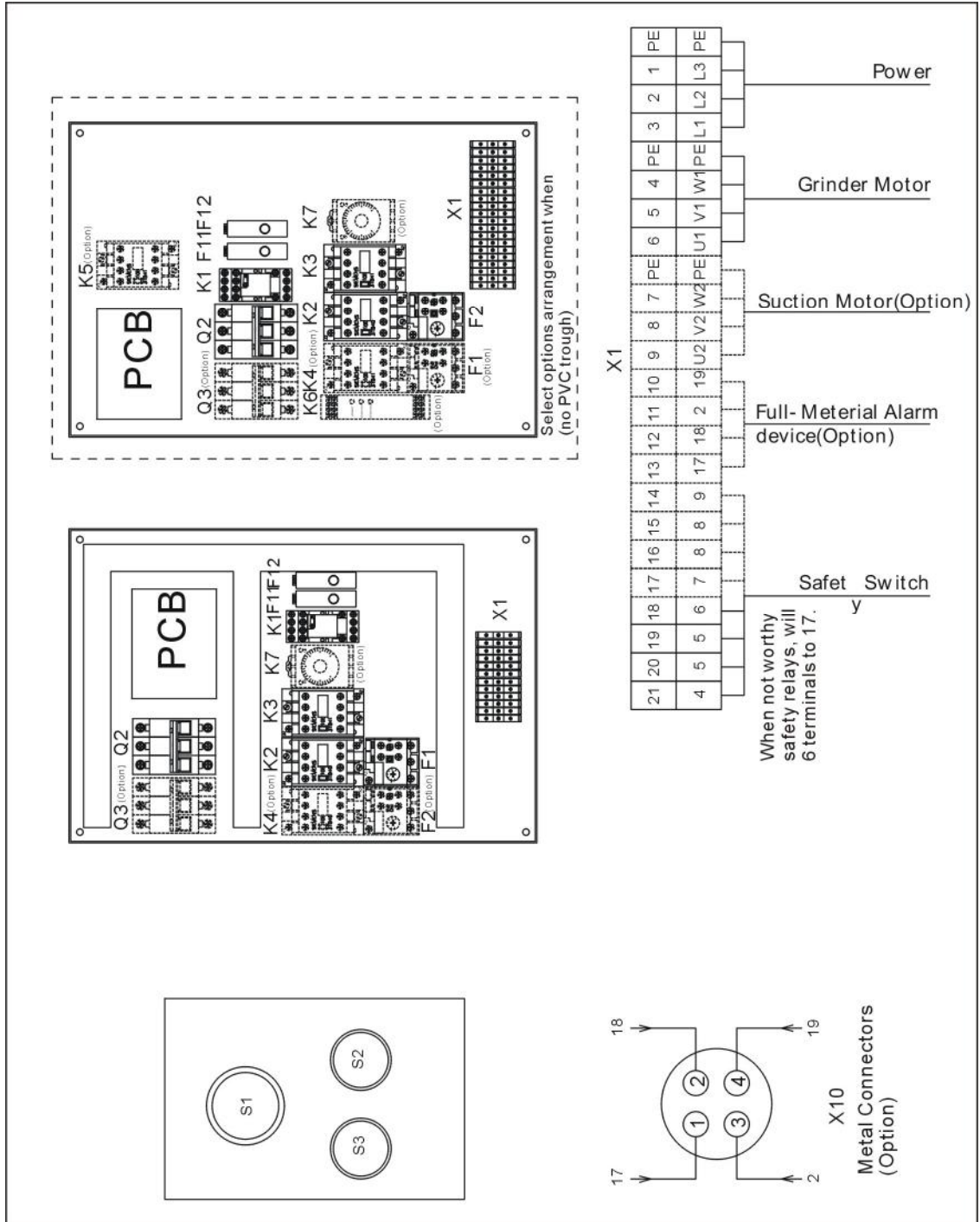

Picture 2-19: Electrical Components Layout (230V)

2.4.8 Electrical Components List (230V)

Table 2-11: SG-2417N/2427N Parts List (230V)

No.	Symbol	Name	Specification	Part No.
1	Q1	Power switch	16A	YE10200300000
2	Q2	Breaker*	10A	YE40600300000
3	Q3	Breaker	5A	YE40603000000
4	K1	Auxiliary relay*	220V 50/60Hz	YE03270700000
5	K2,K3	Contact*or*	220V 50/60Hz	YE00601522000
6	-	Auxiliary contact	1NC	YE00592110100
7	K4	Contact*or*	220V 50/60Hz	YE00601521000
8	K5	Contact*or	220V 50/60Hz	YE00601522000
9	K6	Safety relay	220VAC	YE04372100000
10	K7	Time relay*	220V 50/60Hz	YE86322000000
11	F1	Thermal overload relay*	3.5~5A	YE01160350000
12	F2	Thermal overload relay*	1.8~2.5A	YE01160180000
13	F11 F12	Fuse**	2A	YE41001000000
14	H2	Warning light	220V 50/60Hz	YE83305100200
15	H3	Buzzer	220VAC	YE84222000000
16	S1	Emergency stop switch button	400VAC12 10A	YE11320300000
17	-	Contact block	1NC	YE19340000100
18	S2	STOP switch button	400VAC12 10A	YE11375800000
19	S3,H1	START switch button	400VAC12 10A	YE11325300000
20	-	Contact block	1NO	YE19340000000
21	S4,S5	Safety switch	AZ-15	YE16147600100
22	S4,S5	Safety switch	AZ-16	YE16147600000
23	PCB	PCB*	230VAC	YE80012200200
24	S6	Sensor*	24VDC NPN	YE15122400000
25	MS	Level switch*	3A/250V	YE15000200100
26	X1	Terminal board	32A	YE61250040000
27	-	-	-	YE61253500000
28	-	Terminal board	32A	YE61250040000
29	-	Terminal board	-	YE61253500000
30	-	Terminal board	32A	YE61250040000
31	-	-	32A	YE61250040000
32	X10	Metal joint	4P	YE68025400000
33	M1	Grinder motor	4P	YE68025400100

No.	Symbol	Name	Specification	Part No.
34	M2	Feeding blower	230V 50Hz 0.75kW	-

* means possible broken parts.

** means easy broken part. and spare backup is suggested.

Please confirm the version of manual before placing the purchase order to guarantee that the item number of the spare part is in accordance with the real object.

Table 2-12: SG-2436N Parts List (230V)

No.	Symbol	Name	Specification	Part No.
1	Q1	Power switch	16A	YE10200300000
2	Q2	Breaker*	15A	YE40601500000
3	Q3	Breaker	5A	YE40603000000
4	K1	Auxiliary relay*	220V 50/60Hz	YE03270700000
5	K2,K3	Contactoer*	220V 50/60Hz	YE00601522000
6	-	Auxiliary contact	1NC	YE00592110100
7	K4	Contactoer*	220V 50/60Hz	YE00601521000
8	K5	Contactoer	220V 50/60Hz	YE00601622000
9	K6	Safety relay	220VAC	YE04372100000
10	K7	Time relay*	220V 50/60Hz	YE86322000000
11	F1	Thermal overload relay*	5.5~8A	YE01160550000
12	F2	Thermal overload relay*	1.8~2.5A	YE01160180000
13	F11 F12	Fuse**	2A	YE41001000000
14	H2	Warning light	220V 50/60Hz	YE83305100200
15	H3	Buzzer	220VAC	YE84222000000
16	S1	Emergency stop switch button	400VAC12 10A	YE11320300000
17	-	Contact block	1NC	YE19340000100
18	S2	STOP switch button	400VAC12 10A	YE11375800000
19	S3,H1	START switch button	400VAC12 10A	YE11325300000
20	-	Contact block	1NO	YE19340000000
21	S4,S5	Safety switch	AZ-15	YE16147600100
22	S4,S5	Safety switch	AZ-16	YE16147600000
23	PCB	PCB*	230VAC	YE80012200200
24	S6	Sensor*	24VDC NPN	YE15122400000
25	MS	Level switch*	3A/250V	YE15000200100
26	X1	Terminal board	32A	YE61250040000
27	-	-	-	YE61253500000
28	-	Terminal board	32A	YE61250040000
29	-	Terminal board	-	YE61253500000
30	-	Terminal board	32A	YE61250040000
31	-	-	32A	YE61250040000
32	X10	Metal joint	4P	YE68025400000
33	M1	Grinder motor	4P	YE68025400100
34	M2	Feeding blower	230V 50Hz 1.5kW	-

2.5 Electrical Components Description

2.5.1 Thermal Overload Relay

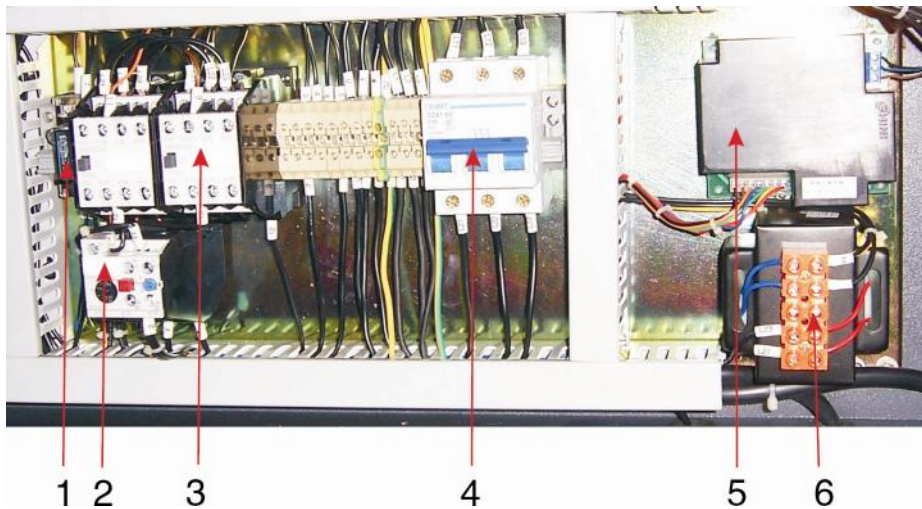

Picture 2-20: Electrical Components Description

1. Fuse, perform the function of overload and short phase protection.
2. Overload relay, can protect the motor or default phase.
3. Contactor, connect or disconnect circuit in a distance.
4. Circuit breaker, isolate or short circuit protection.
5. Reversed PCB.
6. Transformer, provide suitable voltage for control circuit.

2.6 Options

2.6.1 30-second Instant Recycling System

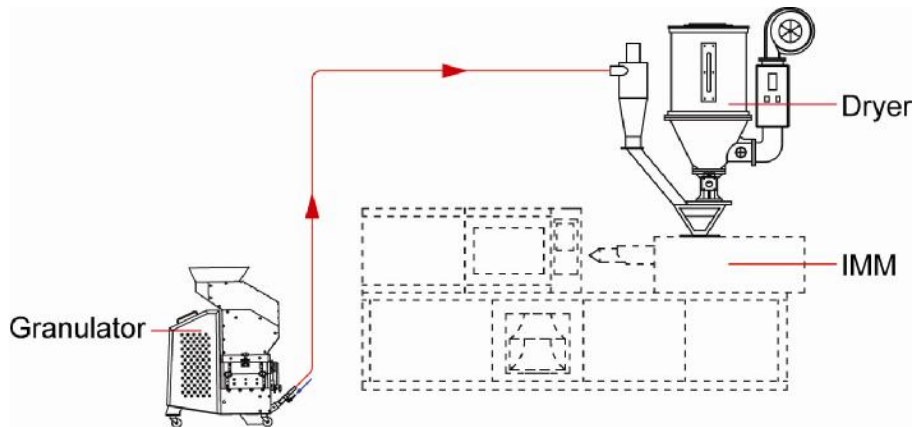

Picture 2-21: 30-second Instant Recycling System

2.6.2 Full-receiver Alarm Devices



Picture 2-22: Warning Light



Picture 2-23: Level Motor

2.6.3 Proportional Valves



Picture 2-24: Control Cabinet and Valve

3. Installation and Debugging



Read through this chapter before installation.



Must abide by the following installation steps to avoid personnel injuries or damage of the machine!



Take great care of handing the blades because they are very sharp and may cause cutting injuries!



Power supply of the machine should be handled by qualified electricians!



Be careful!

Cutting blades must be put balanced, prevent it to rotate itself when do the installation. Keep hands from blades to avoid body injuries!



Attention:

Don't take other person's help to finish the installation, use a wooden board to block the rotating blade to finish it.



Notice!

Use protective gloves since the blades are very sharp.



Caution!

Must use new screw and washer to install the blade.

3.1 Installation Notice

- 1) Make sure voltage and frequency of the power source comply with those indicated on the manufacture's plate, which is attached to the machine.
- 2) Power cable and earth connections should conform with local regulations.
- 3) Use independent power cable and ON / OFF switch. The cable's dia. Should not smaller than those applied in the control box.
- 4) The power cable connection terminals should be tightened securely.
- 5) The machine requires a 3-phase 4-wire power source, connect the power lead (L1, L2, L3) to the live wires, and the earth (PE) to the ground.
- 6) Power supply requirements:
 Main power voltage: +/- 10%
 Main power frequency: +/- 2%

Make at least 1 meter clearance around the machine to facilitate repair and maintenance.

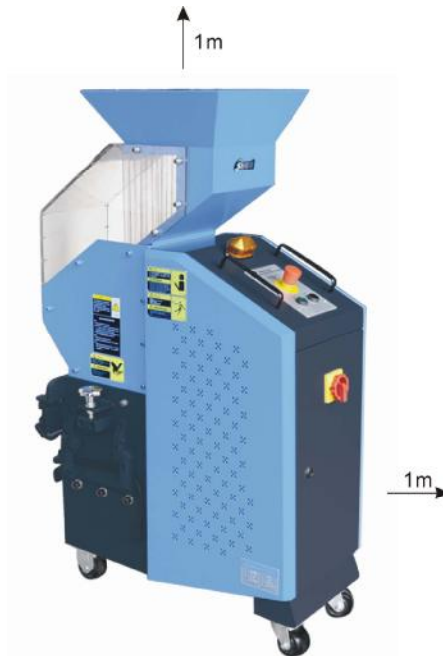

Picture 3-1: Installation Notice

Table 3-1: cutters and other fixing screw torque

Thread size	M10	M12	M14	M16	M18	M20	M22	M24
Axial force (N)	23.8	34.5	47	65.5	78.5	103	129	149
Fixing torque (Nm)	50	86	135	215	290	420	570	730

3.2 Installation Place

Check and make sure the installation ground is level; there is enough intensity when it is running. Lockup the castors.

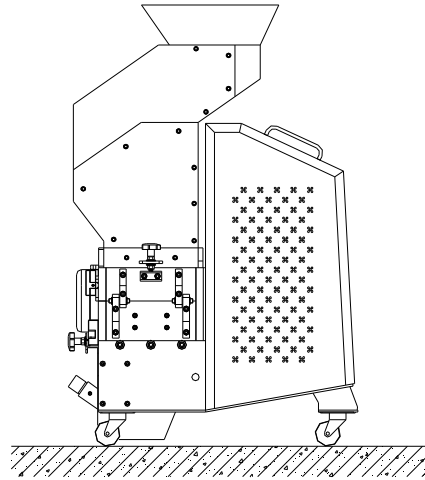

Picture 3-2: Installation Place

3.3 Installation of Bearing and Cutter Shaft

- 1) Install the bearing 2. bearing washer 1. bearing sleeve 7 into the bearing base 3.
- 2) Insert the blade shaft 4 into the bearing sleeve vertically 7. Then sleeve the staggered blade 5 and the teeth blade 6 on the bearing spacing.

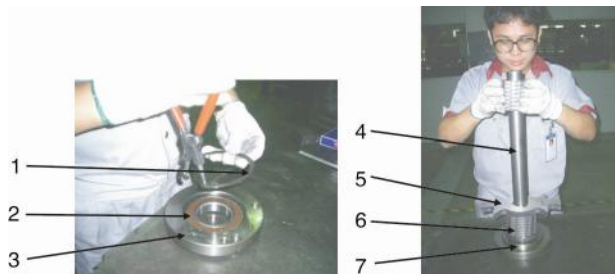

Picture 3-3: Installation of Bearing and Cutter Shaft 1

- 3) Put the Cutter Shaft 2 into the cutting chamber 1, let both terminals of the bearing tallies with the grooves.



Picture 3-4: Installation of Bearing and Cutter Shaft 2

- 4) Fix the bearing base on the cutting chamber.



Picture 3-5: Installation of Bearing and Cutter Shaft 3



Notice!

Daub the lubrication on the bearing and bearing base. Use proper twisting force to lock the screw tightly.

- 4) Use a wrench to tight up all the screws on bearing block or cutting chamber and lock them up with right torque (M12×25).
- 5) After installed the rotating Cutter Shaft to the housing, mount fixed blades that correspond with teeth cutters on pressing block and align their holes. Lockup the fixing screw (LOCTITE243 thread fixing glue is recommended). (Fixing screw for front fixed blade is M10×30, while for back fixed blade is M10×35).



Picture 3-6: Installation of Teeth Cutter and Fixed Blade



Caution!

In order to avoid personal injury and machine damage, the lockup screws has to be tightened.



Attention!

Blades are extremely sharp; to avoid injuries, please waer gloves before and during installation.

3.4 Installation of Reduction Gear



Notice!

To stop blade rest shaft rotating while installation, use a thick wood block to stuck rotate blades!

- 1) Firstly fasten fixed plate onto reduction box via inner hex bolt (M8x20), then fit the box to cutter shaft to match groove holes with the shaft. At last, mount sensor and fasten it with inner hex bolt (M12x30).



Picture 3-7: Installation of Reduction Gear 1

- 2) Fix the fixed plate of motor on right bearing holder at bottom of chamber via inner hex bolt (M16x40) and make sure lock bolts tightly to avoid motor swaying.



Picture 3-8: Installation of Reduction Gear 2



Caution!

The cutting blade rest shall be put stably and avoid cutter self-rotation. At the time of operating, hand shall stay away from the cutting tool to avoid bodily injury.

3.5 Installation of Feed Box, Feed Port and Storage Bin

- 1) Lift up the feed box to fix it onto the cutting chamber with screws (M8×35).



Picture 3-9: Installation of Feed Box, Feed Port and Storage Bin 1

- 2) Hold the feed port, and insert it into the feed box.



Picture 3-10: Installation of Feed Box, Feed Port and Storage Bin 2

- 3) Before fixing the feed port, place the plastic strips at the top of feed box and let feed port press against it.
- 4) Lay down the feed port and align its screw holes with the screw holes on the feed box, then lock the screws up (M8×20).



Picture 3-11: Installation of Feed Box, Feed Port and Storage Box 3

- 5) Hold the storage bin with both hands and push it into its right position along the slide way.



Picture 3-12: Installation of Feed Box, Feed Port and Storage Box 4

- 6) Lock up plum blossom handle.



Picture 3-13: Installation of Feed Box, Feed Port and Storage Box 5



Caution!

Locknut is necessary for keeping screws falling into cutting chamber.

4. Operation Guide



Wear gloves during operating to avoid personal injury!



Wear goggles during operating to avoid personal injury!



Blade or rotor may be loose, make sure check them before operation:

- 1) Check if blades are damaged and loose.
- 2) Check if rotor is damaged and loose.

Please contact local agents or Shini Company if any situation above has been found.

4.1 Startup Pretest

Unpainted part of the machine has been covered with antirust oil. Before use, the antirust oil should be cleaned.

- 1) Clean with a towel.
- 2) Wash with a towel dipping with amyl acetate.

4.1.1 Before the First Startup

- 1) Check whether the granulator is in the level state.
- 2) Check the space of the cutting tools to see whether the lockup screws of the blades are tightened.
- 3) Before granulation, ensure the rotation direction of main shaft is in line with that marked in nameplate.

4.1.2 After Startup for 2 Hours

- 1) Check the space of the cutting tools of the fixed blades and rotating blades again; check whether the lockup screws of the blades are loose.
- 2) Check the position-adjusting screws of the motor and check whether the position-adjusting screws are tightened.

4.1.3 After Startup for 20~30 Hours

After 20~30 hours machine running in full load, users need to check temperature on motor surface and check if there oil leaks.

4.2 Circuit Connection



Notice!

The installation of the granulator's circuit must be conducted by the professional electricians.

- 1) Check if feed box is fully closed;
- 2) Check if storage bin is fully closed;
- 3) Ensure the main power switch is in ON position.
- 4) Check if emergency stop is under action;
- 5) Start the granulator via pressing the START button and stop the granulator via pressing the STOP button.
- 6) The granulator needs some time to fully come to a halt; after full stop, check whether the running direction is clockwise.



The cutting tools may be damaged and the granulating capability will be reduced if there is a wrong running direction. Please disconnect the power and transpose any two wires of the three in the main power.

4.3 Open the Feed Box and Storage Bin



Notice!

Before opening the feed box and the storage bin, turn off the main power switch and the power switch of the granulator.



Be careful! The blade is very sharp, please take care.

4.3.1 Open the Feed Box

- 1) Check if the feed box has been emptied. If so, turn off the main power switch.
- 2) Loosen the long star screw and open the feed box.
- 3) Open feed box backwards.

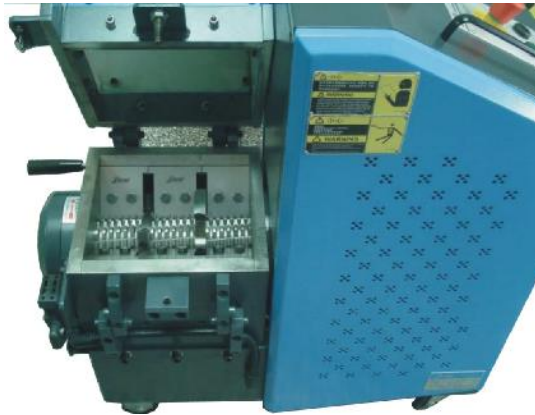

Picture 4-1: Open the Feed Box

4.3.2 Open the Storage Bin

- 1) Turn off granulator power.
- 2) Loosen long star screw.
- 3) Pull out storage bin.

4.4 Shut the Feed Box and Storage Bin

4.4.1 Shut the Feed Box



Notice!

Make sure feed box is fully closed, otherwise machine would not start.

- 1) Check to ensure there is no powder left in the interface or corners.
- 2) Close the feed box forwardly.
- 3) Lock up the star screw and fix the feed box.

4.4.2 Shut the Storage Bin



Note!

Before closing, clean the interface surface.

Be careful!

Don't get squeezed and injured.

- 1) Check no powder or leftover material around the storage box; timely remove them if any.
- 2) Push the storage bin inwards along its slideway.

3) Lock up long star screw and fix storage bin.

4.5 Start and Stop the Granulator

The granulator is controlled by main power switch, safety switch, START/STOP button and emergency stop button.

Main power switch is located at the front control panel. And the startup and stop of the machine is controlled through rotating the main power switch.



Picture 4-2: Main Power Switch

START button and STOP button:

These two buttons control the startup and stop of the machine.

Emergency stop:

This switch can protect and stop machine when accidents happens.

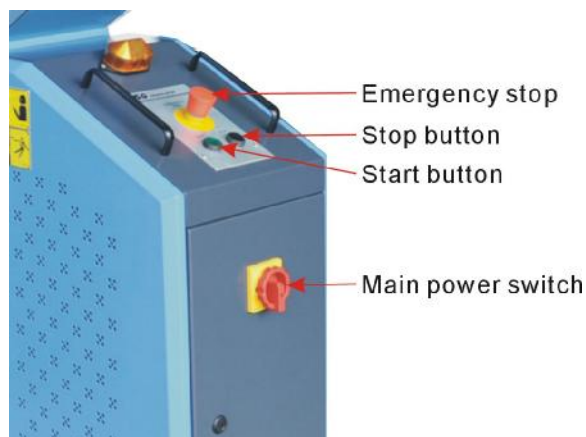

Picture 4-3: START, Emergency Stop and STOP Button



Caution!

If there are ungrinded materials in the feed box or cutting chamber, the granulator shall NOT be stopped, otherwise raw materials will block the

rotor and the motor will be overloaded next time you start the machine up.

4.6 Motor Reversed Protective Function

When there are hard material appear in the feed box and cutting chamber or for other reason the cutting blades can not cut, this unit will enable blade shaft reverse rotating with alarm, it resumes normal operation automatically after 3 seconds later, so to keep granulating material. The alarm dies out after blade shaft rotates normally. If the motor reverse function be started over 3-4 times or more, the motor would be stopped. At this time you can press down the STOP button to cut off the power, and then restart it by press the START button.

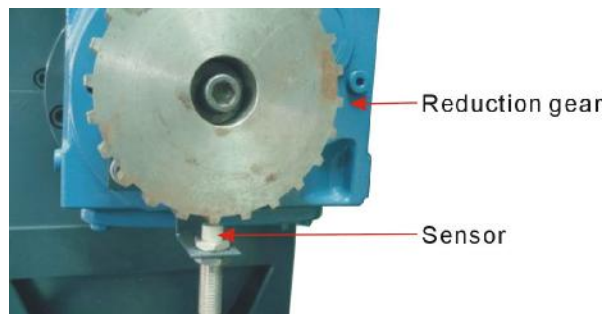

Picture 4-4: Motor Reversed Protection

If the rotor has been seized during operation, its working mode is:

Rotor is seized up, auto stop for 1 sec → reverse rotate for 3 secs → stop for 1 sec → normal rotate →

A. 1) normal → working

2) seized up → stop for 1 sec → reverse rotate for 3 secs → stop for 1 sec → normal rotate

B. 1) normal → working

2) seized up → stop for 1 sec → reverse rotate for 3 secs → stop for 1 sec → normal rotate

C. 1) normal → working

2) seized up → machine stops



Notice!

Mount sensor and ensure its space with big wheel to about 2~4mm.

5. Trouble-shooting

5.1 Granulator Can Not Work

- 1) Check if the emergency stop has not been reset. If not, rotate the Button anti-clockwise to reset it.
- 2) Check whether feed box is fully closed. If not, the machine could not be started.
- 3) Check the motor's overload protector.

The overload protector in the electrical control box will work if the motor overloads. Under that situation, (A) (the green pole) will sprout. Press the Reset button (B) to reset it. Before startup again, check whether there is any material in the granulator.

- 4) Check the space between blades.

Motor overload protection will trip and machine will stop if the blade is very blunt or the space between blades is not correct.

Inspect blades, renew them or re-adjust blades space.



5.2 Stop Due to Other Reasons

Connection failure or looseness of safety switch can also cause shutdown



Note!

Do not disconnect to safety switch or control switch.

6. Maintenance and Repair

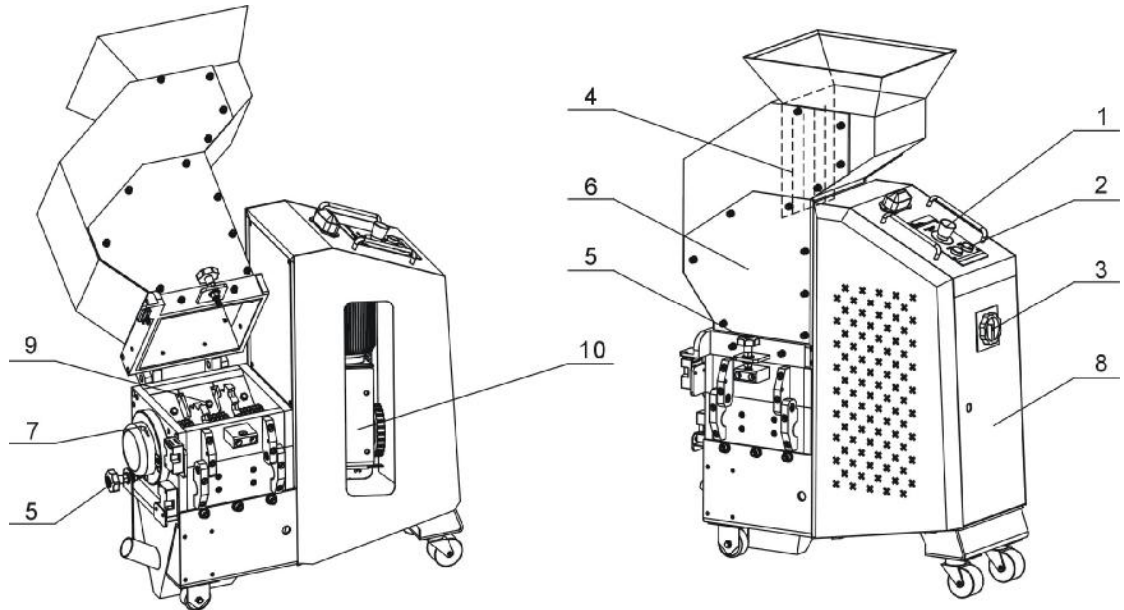

1. Check whether emergency stop works normally. Period: daily
2. Check whether START/STOP button works normally. Period: daily
3. Check whether main power switch works normally. Period: daily
4. Check whether material stopper is intact before startup. Period: daily
5. Check whether star screws in feed box and storage bin are tightened. Period: daily
6. Check whether there is metal in cutting chamber. Period: daily
7. Check whether cutter shaft rotates as showed in the nameplate. Period: daily
8. Check whether electric joints are loose in control cabinet. Period: weekly
9. Check whether fixed screws are loose. Period: monthly
10. Check lubricating oil of reduction gear. Period: half yearly

6.1 Repair

All the repair must be done by professionals to avoid damage to machine and harm to human body.

6.1.1 Replace the Blades



Caution!

Self-rotation exists due to non-balanced forces.



Caution!

Self-rotation also happens when barycenter is unstable.

Wear gloves to avoid being cut and be careful of the sharp blades!



More details about replacing or maintaining the blades to see chapter 3.5. Inject screw thread fixing glue (light blue LOCTITE 243 recommended) to the fixing screw so to avoid slipping and tighten screws up.



Picture 6-1: Blades Maintenance



Caution!

To decrease the possibility of harm to other people, the replacement action must be conducted by oneself.



To avoid self-rotation, block the rotating blades with a thick wood block. Be careful with the sharp blades.



Each time to replace the blade, the screw and insulation ring must be replaced also.

1) Remove the fixed blades



Caution!

To avoid self rotation, block the rotating blade with a thick wood block.

1. Remove the set screws.
2. Remove the fixed blades.
3. Clean the installation surface of the blades.



Picture 6-2: Dismantle Fixed Blades

2) Remove the rotating blades

1. Open the cutting chamber and loosen inner hex screws on bearing block.
2. Take out blade rest.
3. Clean the whole rotating blades and cutting chamber.

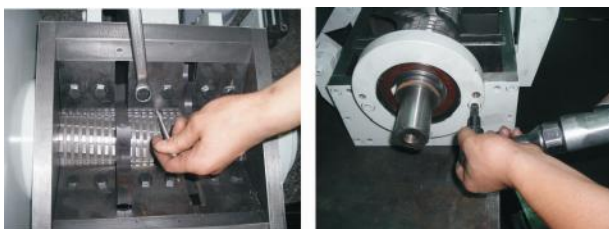

Picture 6-3: Dismantle Rotate Blades



Caution!

Press the pressing block and blade when you remove the last screw so to avoid personal injuries.

3) Install the blades

Clean carefully the fixed blades and rotating blades and then install them.



Caution!

Each time to replace the blade, the screw and insulation ring must be replaced also. Install the rotating blades, then the fixed blades, finally the front fixed blades. More details about replacing or maintaining the blades to see chapter 3.5.

6.2 Transmission

6.2.1 Maintenance of Reduction Gear

Replace lubricating oil after initial motor running for 400 hours, and oil change period later would be 4000 hours running. There should be enough lubricating oil inside motor tank and inspect volume regularly. If oil volume is found to be decreased or oil quality to be deteriorated, supply or renew oil immediately. Note that keep the appearance of mixing motor and gear motor clean by dedusting .

6.3 Check and Maintenance of Gear Motor

Check lubricating oil for every six months or after 3000 hours in operation

1) Check oil level:

- a) Cut power off so to avoid electric shock and wait till the motor get cooled.
- b) Remove oil level plug to check if the oil has been filled up full.
- c) Install oil level plug.

2) Check the lubricating oil:

- a) Cut power off so to avoid electric shock and wait till the motor get cooled.
- b) Open oil drain plug to take samples.
- c) Check viscosity index of the lubricating oil.
If it is evidently turbid, please replace it as soon as possible.
- d) Check the lubricating oil level and install oil level plug.

3) Lubricating oil replacement: Increased viscosity of the lubricating oil will make it harder to discharge the oil, so better replace it when the motor is in its operational temp.

- a) Cut power off so to avoid electric shock.
- b) Lay an oil pan under the oil drainage plug.
- c) Open the oil level plug, air valve and oil drainage plug.
- d) Drain all the lubricating oil out.
- e) Install oil drainage plug.
- f) Fill in new lubricating oil in same brand.
- g) Tight up the oil level plug and air valve.

4) Brand of lubricating oils (ambient temperature : $-10^{\circ}\text{C} \sim 40^{\circ}\text{C}$):

- Mobil: Mobilgear 630
- Shell: Shell Omala 220
- Aral: Aral Degol BG 220
- BP: BP Energol GR-XP 220
- Texaco: Meropa 220

6.4 Maintenance

When carrying out maintenance, ensure that there is no material left in the granulator.



Caution!

All repairing must be conducted by professionals!

6.4.1 Daily Check

- 1) There is rubber shutter in the feed box. If the rubber shutter is damaged, replace it immediately. Otherwise the fragment of the shutter will damage the blades in the cutting chamber.
- 2) Check whether the Emergency Stop works properly. Start the machine and then stop it via Emergency Stop. Rotate the button anti-clockwise to reset the Emergency Stop.
- 3) Check the main power switch, start/stop button.
- 4) Check the reversed rotating function.
- 5) Check star screw, safety screw is part of granulator' safety system, its length is pre-designed, when the screw is loosen, the granulator will stop working so to protect the machine. The thread length of the safety screw is 60mm, damaged screw needs to be replaced by a new one.

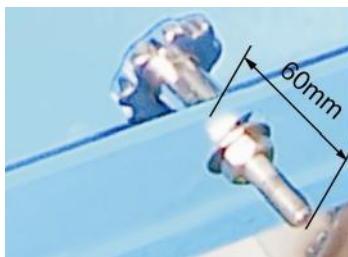

Picture 6-4: Star Screws

6.4.2 Weekly Check

- 1) Check the power wire to see whether there is any damage. If so, replace it immediately.
- 2) Check the safety switch.
- 3) Check whether there is looseness in electrical connections.

6.4.3 Monthly Check

- 1) Check whether blades are loose or abraded.

6.5 Cleaning



Caution: The blade may do harm to human body when opening the feed box!

- 1) Check whether the feed box is emptied before stopping the machine.
- 2) Clean the exterior surface of the feed box.
- 3) Turn off the main power switch.
- 4) Clean the shutter of the feed box with a dust separator.
- 5) Unscrew the star knob to open the feed box backward.
- 6) Clean the interior surface of the feed box.
- 7) Clean both surfaces of the cutting chamber; open the upper cutting chamber and to clean the remained material by using revolving rod to turn the blade shaft.
- 8) Unscrew star screw and take out storage bin.
- 9) Clean storage bin.
- 10) Clean the belt pulleys with bright dust-precipitator.

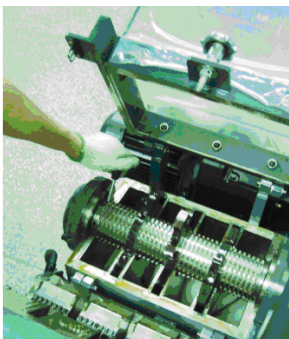

Picture 6-5: Machine Cleaning



Notice!

Finish step 9 for every time of machine cleaning and also it at least has to be done for one time after 300 hours in operation.

6.6 Maintenance Schedule

6.6.1 About the Machine

Model _____ SN _____ Manufacture date _____

Voltage _____ Φ _____ V Frequency _____ Hz Power _____ kW

6.6.2 Check after Installation

- Check if the lockup screws of the fixed blades are locked firmly.
- Check whether star screws are tightened.
- Check if the flange of the speed reducer has been locked firmly.

Electrical Installation

- Voltage: _____ V _____ Hz
- Specs of the fuse: 1 Phase _____ A 3 Phase _____ A
- Check phase sequence of the power supply.

6.6.3 Daily Check

- Check main power switch.
- Check emergency stop button.
- Check start / stop button.
- Check material check plate (strip) is perfect or not.
- Check whether emergency stop and safety switch works normally.
- Clean cutting chamber and feeding hooper.
- Check whether start, stop and power switches are normal.

6.6.4 Weekly Check

- Check all the electrical cables.
- Check if there are loose connections of electrical components.
- Check whether fixed screw loose for the blade.
- Check if there is abnormal noise, vibration and heat in reduction gear.
- Check the cracking window

6.6.5 Monthly Check

- Check the status of the belt.
- Check the overload protection function of the motor.
- Check the tightness of the blades.

6.6.6 Check Half-yearly or Every 1000 Running Hours

- Check or replace lubrication for gear motor.
- Check lubrication of bearing.
- Evaluation of the machine condition.

6.6.7 3 year Checking

- PC board renewal.
- No fuse breaker renewal.