

SG-36 series

Sound-proof Central Granulators

Date: Apr, 2013

Version: Ver.B (English)



Contents

1. General Description	11
1.1 Coding Principle	12
1.2 Feature	12
1.3 Technical Specifications	14
1.3.1 Technical Specifications.....	14
1.3.2 Dimensions	16
1.4 Safety Regulations	17
1.4.1 Safety signs and labels	17
1.4.2 Transportation and Storage of the Machine	20
1.5 Exemption Clause	22
2. Structural Features and Working Principle	24
2.1 General Description	24
2.1.1 Working Principle	24
2.2 Safety System	25
2.2.1 Emergency Stop.....	25
2.2.2 Safety Switch	26
2.2.3 Door Lock.....	26
2.3 Assembly Drawing.....	28
2.3.1 Assembly Drawing	28
2.3.2 Parts List.....	29
2.3.3 Cutting Chamber.....	31
2.3.4 Cutting Chamber Parts List.....	31
2.3.5 BladeRest	33
2.3.6 Transmission Parts	34
2.3.7 Transmission Parts Parts List	34
2.3.8 Screen.....	35
2.3.9 Screen Parts List.....	35
2.3.10 Screen Bracket.....	35
2.3.11 Screen Bracket Parts List.....	35
2.3.12 Blower	37
2.3.13 Blower Parts List	37

2.3.14	Feed Box, Insulative Box and Shutter	38
2.3.15	Feed Box, Insulative Box and Shutter Parts List	38
2.3.16	Storage box.....	39
2.3.17	Storage box Parts List.....	39
2.3.18	Main Body	40
2.3.19	Main Body Parts List	40
2.4	Wiring Diagram.....	41
2.4.1	Main Circuit (400V)	41
2.4.2	Control Wiring Diagram (400V)	42
2.4.3	Electrical Components Layout (400V).....	45
2.4.4	Electrical Components List (400V).....	47
2.4.5	Main Circuit (230V)	51
2.4.6	Control Wiring Diagram (230V)	52
2.4.7	Electrical Components Layout (230V).....	54
2.4.8	Electrical Components List (230V).....	58
2.5	Electrical Components Instruction	62
2.5.1	Microprocessor Board (PCB)	62
2.6	Optional Accessories.....	64
2.6.1	DS-36 Dust separate System.....	64
2.6.2	Clean.....	66
2.6.3	Screen.....	66
2.6.4	Cutters	67
3.	Installation and Debugging	68
3.1	Installation Notice	69
3.2	Installation Place	72
3.3	Installation of Bearing and Blade Rest.....	74
3.4	Installation of Belt Pulley and Motor	74
3.4.1	SG-3650.....	74
3.4.2	SG-3675.....	76
3.5	Installation of Fixed Blades and Rotating Blades.....	79
3.6	Installation of Storage box, Screen and Screen Bracket	79
3.7	Installation of Feed Box and Feed Inlet	80
4.	Operation Guide.....	83
4.1	Startup Pretest.....	83

4.1.1	Before the First Startup	83
4.1.2	After first startup for 2 hours.....	84
4.1.3	After first startup for 20~30 hours.....	84
4.2	Circuit Connection	84
4.2.1	Check the running direction of the motor	84
4.2.2	Check the running direction of the blower	85
4.3	Open the Feeding Hopper, Screen and the Storage box.....	85
4.3.1	Open the feeding hopper	85
4.3.2	Open the storage box and screen	86
4.4	Close the screen bracket; the storage box and the feeding hopper....	86
4.4.1	Installation of the screen bracket and the storage box.....	86
4.4.2	Close the feed box	87
4.5	Turn Off and Stop the Granulator	87
4.6	Blades Installation Adjusting.....	88
5.	Trouble Shooting	89
5.1	Granulator Can Not Work	89
5.2	Stop Due to Other Reasons.....	89
6.	Maintenance and Repair.....	91
6.1	Repair.....	91
6.1.1	Replace the Blades	91
6.2	Transferring	93
6.2.1	Daily maintenance of V belts.....	93
6.2.2	Adjustments of V belts	94
6.3	Lubrication.....	94
6.3.1	Lubricating oils	95
6.3.2	Please grease the bearing with lubricating oils periodically	95
6.4	Cleaning	95
6.5	Maintenance Schedule	97
6.5.1	About the Machine	97
6.5.2	Check after Installation.....	97
6.5.3	Daily Check.....	98
6.5.4	Weekly Check	98
6.5.5	Monthly Check	98
6.5.6	Check Half-yearly or Every 1000 Running Hours.....	98

6.5.7 3 year Checking	99
-----------------------------	----

Form index

Chart 1-1: Technical Specifications	14
Chart 2-1: Parts List.....	29
Chart 2-2: Cutting Chamber Parts List.....	31
Chart 2-3: BladeRest Parts List	33
Chart 2-4: Transmission Parts Parts List	34
Chart 2-5: Screen Parts List	35
Chart 2-6: Screen Bracket Parts List	35
Chart 2-7: Blower Parts List.....	37
Chart 2-8: Feed Box, Insulative Box and Shutter Parts List.....	38
Chart 2-9: Storage box Parts List	39
Chart 2-10: Main Body Parts List.....	40
Chart 2-11: Electrical Components List of SG-3650(400V)	47
Chart 2-12: Electrical Components List of SG-3675 (400V)	49
Chart 2-13: Electrical Components List of SG-3650(230V)	58
Chart 2-14: Electrical Components List of SG-3675 (230V)	60

Picture index

Picture 1-1: Dimensions	16
Picture 2-1: Body switch	24
Picture 2-2: Working Principle	24
Picture 2-3: Safety System	25
Picture 2-4: Emergency Stop.....	26
Picture 2-5: Safety Switch	26
Picture 2-6: Door Lock.....	27
Picture 2-7: Assembly Drawing.....	28
Picture 2-8: Cutting Chamber	31
Picture 2-9: BladeRest.....	33
Picture 2-10: Transmission Parts.....	34
Picture 2-11: Screen.....	35
Picture 2-12: Screen Bracket.....	35
Picture 2-13: Blower	37
Picture 2-14: Feed Box, Insulative Box and Shutter	38
Picture 2-15: Storage box.....	39

Picture 2-16: Main Body	40
Picture 2-17: Main Circuit (400V).....	41
Picture 2-18: Control Wiring Diagram 1 (400V)	43
Picture 2-19: Control Wiring Diagram 2 (400V)	44
Picture 2-20: Electrical Components Layout (Not Opt For Safety Relay) (400V)	45
Picture 2-21: Electrical Components Layout (Opt For Safety Relay) (400V) ...	46
Picture 2-22: Main Circuit (230V).....	51
Picture 2-23: Control Wiring Diagram 1 (230V)	52
Picture 2-24: Control Wiring Diagram 2 (230V)	53
Picture 2-25: Electrical Components Layout (SG-3675 Not Opt For Safety Relay) (230V)	54
Picture 2-26: Electrical Components Layout (SG-3675 Opt For Safety Relay) (230V)	55
Picture 2-27: Electrical Components Layout (Not Opt For Safety Relay) (230V)	56
Picture 2-28: Electrical Components Layout (Opt For Safety Relay) (230V) ...	57
Picture 2-29: PCB.....	62
Picture 2-30: Electrical Components Description.....	63

Picture 2-31: Installation illustrative Photo	64
Picture 2-32: Screen	67
Picture 3-1: Installation Space	69
Picture 3-2: Installation Place 1	72
Picture 3-3: Installation Place 2	72
Picture 3-4: Installation Place 3	73
Picture 3-5: Installation of Bearing and Blade Rest	74
Picture 3-6: Installation of Belt Pulley and Motor 1 (SG-3650)	74
Picture 3-7: Installation of Belt Pulley and Motor 2(SG-3650)	75
Picture 3-8: Installation of Belt Pulley and Motor 2(SG-3650)	75
Picture 3-9: Installation of Belt Pulley and Motor 2 (SG-3650)	76
Picture 3-10: Installation of Belt Pulley and Motor 5 (SG-3650)	76
Picture 3-11: Installation of Belt Pulley and Motor 1 (SG-3675)	76
Picture 3-12: Installation of Belt Pulley and Motor 2 (SG-3675)	77
Picture 3-13: Installation of Belt Pulley and Motor 3 (SG-3675)	77
Picture 3-14: Installation of Belt Pulley and Motor 4 (SG-3675)	78
Picture 3-15: Installation of Fixed Blades and Rotating Blades	79

Picture 3-16: Installations of Storage box, Screen and Screen Bracket.	80
Picture 3-17: Installation of Feed Box and Feed Inletv 1	80
Picture 3-18: Installation of Feed Box and Feed Inletv 2	81
Picture 3-19: Installation of Feed Box and Feed Inletv 3	81
Picture 3-20: Installation of Feed Box and Feed Inletv 4	81
Picture 3-21: Installation of Feed Box and Feed Inletv 5	82
Picture 4-1: Position-adjusting screws.....	84
Picture 4-2: Blower	85
Picture 4-3: Close the screen bracket; the storage box and the feeding hopper.	86
Picture 4-4: Circuit switch	87
Picture 4-5: Blades Installation Adjusting	88
Picture 6-1: Remove the rotating blades	92
Picture 6-2: Daily maintenance of V belts.....	94
Picture 6-3: Adjustments of V belts.....	94
Picture 6-4: Oil throat.....	95

1. General Description



Please read this manual carefully before using this machine in order to operate correctly against any damage caused due to improper operation.



Note!

Always take great care when the knives are within reach, they are very sharp and can cause personal injury.



Forbidden to process flammable or toxic material!

SG-36 series sound-proof central granulators are suitable for centralized recycling of wastes or rejected parts from injection moulding, blow moulding or extrusion lines. The machines feature optimized structure, easy operation, and quick blade replacement. Staggered rotating blades can easily grab and cut materials. This design makes the machine work more efficiently and can reduce waste of energy to the minimum. This granulator has various models with wide application to meet different customers' demand.



Model: SG-3650

1.1 Coding Principle

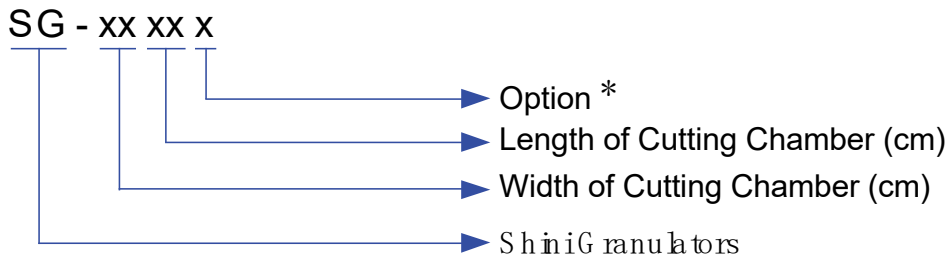

Note: *

S=Smaller Motor Power P=Paddle Blade(Except SG-23 Series)

H=Higher Motor Power R=For Stainless Steel made Feed Port and Storage Tank

F=Fiber-added FAD=Full-receiver Alarm Device CE=CE Conformity

1.2 Feature

Standard configuration

- 1) SG-36 series adopts paddle blades design.
- 2) Paddle blades design allows increased efficiency and reduced energy consumption.
- 3) The blade material is imported steel to ensure high quality and high durability.
- 4) Full-closed design and sound-proofing ensure low noise level.
- 5) Equipped with electrical current relay, motor overload protector and other multiple safety devices.
- 6) Cyclone dust separator can effectively remove the air from regrind and facilitates the material collecting.
- 7) Dust collecting bag brings easiness for dust cleaning and reduce contamination.
- 8) Regrind conveying system as standard.
- 9) Anti-vibration pads absorb vibration from SG-36 series.

Accessory option

- 1) For granulating fibre-added material, increase fibre-added granulator model for choose. Adopt surface-hardening treatment on the material contacting components. SG-36 fibre-added model blade material used V-4E joint with S50C.
- 2) Dust separator, full-receiver alarm device and special screens.

All service work should be carried out by a person with technical training or corresponding professional experience. The manual contains instructions for both handling and servicing. Chapter 7, which contains service instructions intended for service engineers. Other chapters contain instructions for the daily operator.

Any modifications of the machine must be approved by SHINI in order to avoid personal injury and damage to machine. We shall not be liable for any damage caused by unauthorized change of the machine.

Our company provides excellent after-sales service. Should you have any problem during using the machine, please contact the company or the local vendor.

Headquarter and Taipei factory:

Tel: (886) 2 2680 9119

Shini Plastics Technologies (Dongguan), Inc:

Tel: (86) 769 8111 6600

Shini Plastics Technologies India Pvt.Ltd. :

Tel: (91) 250 3021 166

1.3 Technical Specifications

1.3.1 Technical Specifications

Chart 1-1: Technical Specifications

Model	SG-3650	SG-3675
Motor Power (kW, 50 / 60Hz)	18.5 / 21.3	30 / 34
Rotor Speed (r.p.m. 50 / 60Hz)	540 / 650	540 / 650
Conveying Blower (kW, 50 / 60Hz)	1.1 / 1.3	1.5 / 1.9
Teeth-cutter Material	SKD11	SKD11
Number of Fixed Blades	2	4
Number of Rotating Blades	6	6
Cutting Chamber (mm)	360×500	360×750
Max. Throughput (kg/hr)	620	800
Noise Level dB (A)	100~105	100~105
Regrinds Conveying Device	✓	✓
Cooling Device	✓	✓
Dia. of Screen Hole (Φ10 mm)	✓	✓
Flywheel	✓	✓
Dia. of Screen Hole (Φ8,Φ12,Φ17,Φ25 mm mm)	○	○
Magnetically Charged Hood	○	○
Dust Separator (DS-36)	○	○
Level Detector	○	○
Optional Conveying Blower (kW)	○ (1.5)	○ (2.2)
Modified Feed Chutes for Conveyors	○	○
Dimensions		
H (mm)	3155	3155
H1 (mm)	1980	1980
H2 (mm)	1520	1520
W (mm)	1260	1510
W1 (mm)	2120	2120
W2 (mm)	480	480
W3(mm)	190	190
D (mm)	1715	1715
D1 (mm)	1250	1250
Weight (kg)	1480	1730

Note: 1) "✓" standard, "○" optional.

- 2) Modified into stainless steel made feed hopper cover plate and storage tank. Add "R" at model behind.
- 3) SKD11 is material code number of Japanese JIS standard.
- 4) When granulating materials with fibers or similar to fibers (like CPVC etc.), it is suitable to select granulators with special quenching process in for cutting chamber and blades, and also denotes "F" behind the model.
- 5) Max. Capacity of the machine is subjected to diameter of screen mesh size and composition of material.
- 6) Noise level will vary with different materials and motor types.
- 7) For avoiding plastic to adhibit the blade, all materials should be crushed at normal temperature.

8) Power supply: 3, 230 / 400 / 460 / 575V, 50 / 60Hz.

1.3.2 Dimensions



Picture 1-1: Dimensions

1.4 Safety Regulations

Follow the instructions in this manual to avoid personal injury and damage to machine components.

The following safety measures shall be followed when operating the granulator.

1.4.1 Safety signs and labels



Electrical installation must only be done by a competent electrician!



Before the granulator is opened for servicing and maintenance, always disconnect the power with both the main switch and the control switch on the granulator.



Never put any part of your body through the granulator openings, unless both the main switch and the control switch on the granulator are in "Off" position.



High voltage! Danger!

This sign is attached on the control box and the wiring box.



Be careful with the rotating knives, they are very sharp and can cause personal injury!



If the rotor must be turned manually-do this with great care!



The granulator should not be able to start before the hopper and screen bracket are properly closed.



Attention please!

Ear protection is used during granulating of plastic materials.



Never remove protective sponge or quick coupling clips adjacent to the outlet of storage bin.



Make sure the power has been cut off before opening the feed box.



Loading blower applicable to convey regrind and powder and it requires that the temperature of regrind and powder should not be more than 80°C.



The loading blower has great suction power and it is easy to get goods or clothes sucked into, so it should have a protective cover.



Air inlet dust clean.





Concerning SG-36 the cutting chamber should be heat-processed and the blades must be changed before the granulators deal with fibre added material.



Attention!

No need for regular inspection because all the electrical parts in the control unit are fixed tightly!

When operate the granulator, please notice the following signs

	 Hazard High voltage! May lead to casualty or other serious danger. Please cut off the power before repairing. Circuit diagram should only be changed by professionals. Grounding is necessary before turning on power.
---	---

	<p>Warning Pinch risk when moving belt. Take out or open protective cover is not allowed when it is running.</p>
	<p>Warning There is a pinch risk for this protective cover. Keep some distance away from that.</p>
	<p>Warning The cutter are very sharp, can cause injury take out or open protective cover is not allowed when it is running keep some distance away from the cutters.</p>
	<p>Notice Read the instruction manual carefully before operating before start, do the safety device test according to the instruction. It is not allowed to change the design of the machine unless it is approved by the manufacture.</p>
	<p>Water outlet: drainage outlet.</p>
	<p>Water inlet: inlet for replenishing water and cooling water.</p>

1.4.2 Transportation and Storage of the Machine

Transportation

- 1) SG-36 series of granulators are packed in plywood cases with wooden pallet at the bottom, suitable for quick positioning by fork lift.
- 2) After unpacked, castors equipped on the machine can be used for ease of movement.
- 3) Do not rotate the machine and avoid collision with other objects during transportation to prevent improper functioning.
- 4) The structure of the machine is well-balanced, however, it also should be handled with care when lifting the machine to prevent falling down.
- 5) The machine and its attached parts can be kept with a temperature from -25°C to $+55^{\circ}\text{C}$ for long distance transportation while for a short distance, it can be transported with temperature under $+70^{\circ}\text{C}$.

Storage

- 1) SG-36 series should be stored indoors with temperature kept from 5°C to 40°C and humidity below 80%.
- 2) Disconnect all power supply and turn off main switch and exigency stop switch
- 3) Keep the whole machine, especially the electrical components away from water to avoid potential troubles caused by the water.
- 4) Use plastic film to cover the machine tightly to prevent the machine from dust and rainwater.

Working environment

The machine should be operated:

- 1) Indoors with a dry environment of max. temperature $+45^{\circ}\text{C}$ and humidity no more than 80%.

Do not use the machine:



- 1) If it is with a damaged cord.
- 2) On a wet floor or when it is exposed to rain to avoid electric shock.
- 3) If it has been dropped or damaged until it is checked or fixed by a qualified serviceman.
- 4) This equipment works normally in the environment with altitude over 1,000m.
- 5) At least 1m surrounding space is requested when this equipment is running. Keep this equipment away from flammable sources at least two meters.
- 6) In the work area of vibration and strong magnetic force

Rejected parts disposal

When the equipment has run out its life time and can not be used any more, unplug the power supply and dispose of it properly according to local code.



Fire hazard!

In case of fire, CO₂ dry powder fire extinguisher should be applied.



Flammable materials or materials which are contaminated by flammable materials/liquid should not be processed in the granulator. Serious risk of fire or explosion may cause personnel injury.



It is very important to tighten the screw as required torque.



If process item is longer than feed port, please cut long items into half until the length is shorter than the feed port before processing.



Please don't put materials into the granulator if they are thinner than 2 mm and are soft and flexible, like rubber.

1.5 Exemption Clause

The following statements clarify the responsibilities and regulations born by any buyer or user who purchases products and accessories from Shini (including employees and agents).

Shini is exempted from liability for any costs, fees, claims and losses caused by reasons below:

1. Any careless or man-made installations, operation and maintenances upon machines without referring to the Manual prior to machine using.
2. Any incidents beyond human reasonable controls, which include man-made vicious or deliberate damages or abnormal power, and machine faults caused by irresistible natural disasters including fire, flood, storm and earthquake.
3. Any operational actions that are not authorized by Shini upon machine, including adding or replacing accessories, dismantling, delivering or repairing.
4. Employing consumables or oil media that are not appointed by Shini.

2. Structural Features and Working Principle

2.1 General Description

SG-36 series granulators applicable to granulate waste plastic for recycling use, mount magnet at the material inlet to clean out metal scraps and contaminations before granulating so to prevent metal scraps from getting into cutting chamber and bringing damage to the blades.

The granulator is controlled through the main power switch, safety switch, "Start/Stop" button and "Emergency stop" button.



Picture 2-1: Body switch

2.1.1 Working Principle

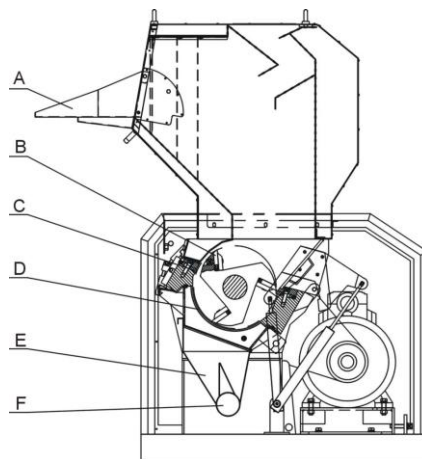

Parts name:

A. Material inlet

B. Rotating blade

C. Fixed blade

D. Screen

E. Storage bin

F. Discharging pipe

Picture 2-2: Working Principle

The waste materials enter the cutting chamber via material inlet (A). The rotating blade (B) and fixed blade (C) grind the materials. The particle size is controlled by the size of screen (D). The screen (D) is located behind of the cutting chamber. Thus it is convenient to replace screen to other different sizes. The granulated materials are dropped into the storage box (E) via the screen and be conveyed via discharging pipe (F).

The external material-conveying blower absorbs the granulated materials into the cyclone dust separator to separate the air and dust.

The obtained particles can be reused directly or sent to somewhere for storage. The foldable feed box has a good tunnel for maintenance, thus it is very convenient for cleaning.

2.2 Safety System

The granulator possesses a highly-secure safety system to avoid accident during the operation. The fast-rotating blade in the granulator is prone to result in an accident.

Thus, the safety system can protect human body. The safety system can be altered under no circumstances, otherwise the machine would in dangerous situation and can do harms. All repair and maintenance work should be carried out by the professionals.

If any safety system change takes place, no commitment will be fulfilled and all replaced components should be provided by SHINI.

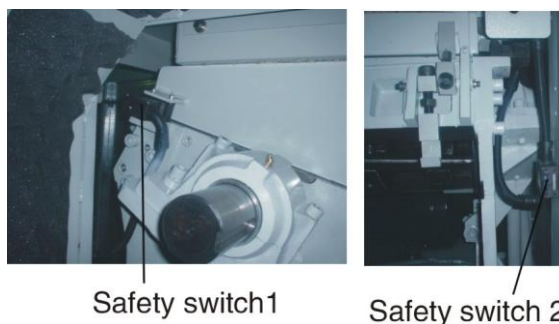

Picture 2-3: Safety System

2.2.1 Emergency Stop

Emergency stop is a red button on the control panel. Press it then the machine will stop working. It can be reset by turning the button as the arrow direction (anticlockwise).



Emergency stop button

Picture 2-4: Emergency Stop

2.2.2 Safety Switch

There are safe position switches for circuit breakers in the granulator. If there is any change, for example, the position of the door or the feed box changed or the circuit breaker is loose, the safety position switch will cut the power off and stop the machine.

Two safety switches may be involved. One is located between the feed box and the cutting chamber and the other links to the lock in the machine door.



Safety switch

Picture 2-5: Safety Switch

2.2.3 Door Lock

The lock of the machine is a long hexagonal screw, which can extend the time

of door opening to avoid any injury. When opening the door, this hexagonal screw shall be loosened. Loosening the door-lock needs a period of time avoiding personnel injury.

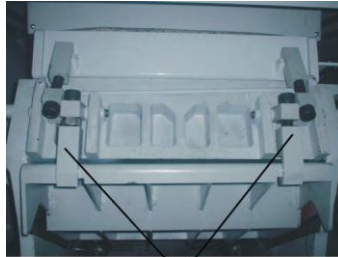

Hothook

Picture 2-6: Door Lock

Keep in mind before you start the granulator:

- 1) Whether the feed box has been tightly locked or not.
- 2) Whether the screen or the storage box has been well installed or not.
- 3) Close the machine door and screw the star screw tightly.

2.3 Assembly Drawing

2.3.1 Assembly Drawing

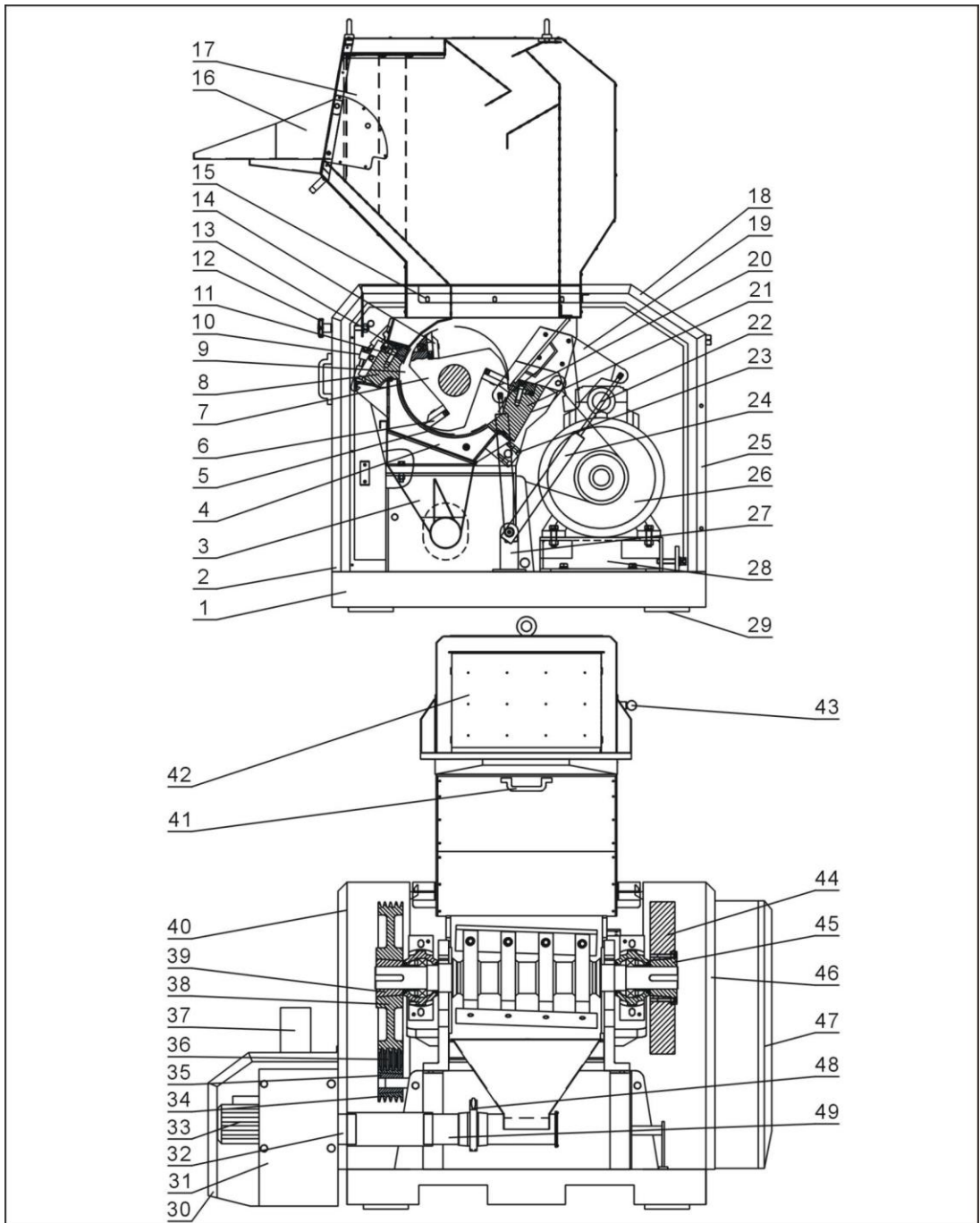

Note: Please refer to 2.3.2 material list about the parts code.

Picture 2-7: Assembly Drawing

2.3.2 Parts List

Chart 2-1: Parts List

No.	Name	Part No.	
		SG-3650	SG-3675
1	Frame	-	-
2	Front door	-	-
3	Storage box	-	-
4	Screen bracket	-	-
5	Screen **	BL55365000220	BL55367502020
6	Rotating blade **	BW40365000710	BW42367510010
7	Blade rest	BH11365000710	BH11367512010
8	Front block	BW30365000410	BW30367504010
9	Insert block	BL55364501021	BL55364501021
10	Square block	BH10362600010	BH10362600010
11	Fixed blade **	BW40365000610	BW42367509010
12	Star knob	-	-
13	Front pressing block	BH10365000510	BH10367508110
14	Rotating blade press plate	BH11365000810	BH11367511010
15	Base shelf of feeding hopper	-	-
16	Feed opening	-	-
17	Feed box	-	-
18	After top cover board	-	-
19	Spring fixing plate	-	-
20	Back pressing block	BH10365000110	BH10367513010
21	Back block	BW30365001110	BW30367514010
22	Pneumatic spring	YW01140000000	YW01160000000
23	Sieve net frame pin when a linking piece	-	-
24	Sleeve	-	-
25	Under cover plate after	-	-
26	Motor	YM10418300200	YM10420700200
27	Spring fixing plate	-	-
28	Motor installed base	-	-
29	Anti-vibration pad	-	-
30	Blower cover	-	-
31	Blower stents components	-	-
32	Side cover over	-	-
33	Blower *	BM30112200050	BM30152300050

34	Small belt pulley	YW30180400000	YW30180400000
35	Small belt pulley taper sleeve	YW30254800000	YW30255500000
No.	Name	Part No.	
		SG-3650	SG-3675
36	V belt *	YR00059000000	YR00059000000
37	Blower flange	-	-
38	Big belt pulley	YW30500400000	YW30500400000
39	Big belt pulley taper sleeve	YW30353507500	YW30353507500
40	Left side plate	-	-
41	Handle	BW20012000140	BW20012000140
42	Material fender	-	-
43	Spring bolt in feeding port	-	-
44	Flywheel	BW30003600110	BW30003600110
45	Flywheel hood	BW30036000010	BW30036000010
46	Right side plate	-	-
47	Door of control box	-	-
48	Stainless steel pipe clamp 4"	YW07000400000	YW07000400000
49	Blower connection pipe	-	-

* means possible broken parts.

** means easy broken part. and spare backup is suggested.

Please confirm the version of manual before placing the purchase order to guarantee that the item number of the spare part is in accordance with the real object.

2.3.3 Cutting Chamber

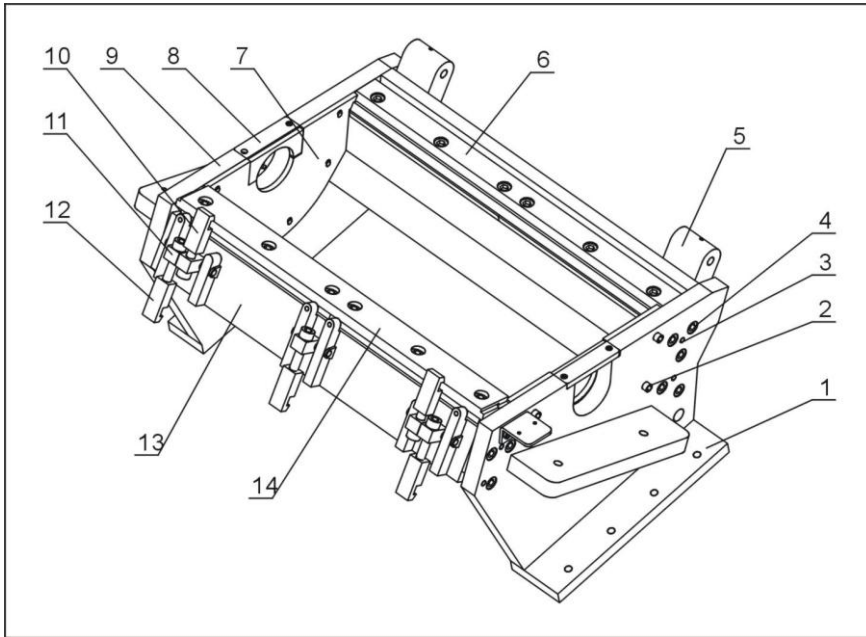

Picture 2-8: Cutting Chamber

2.3.4 Cutting Chamber Parts List

Chart 2-2: Cutting Chamber Parts List

No.	Name	Quantity
1	Right side plate	1
2	Inner hexagon socket cap screw M10×50	10
3	Column pin 10×50	8
4	Inner hexagon socket cap screw M16×50	16
5	Back block	1
6	Back pressing block	1
7	Insert block	2
8	Sidewall block ring	2
9	Left side plate	1
10	Feed box iron hook	2
11	Square block	4
12	Screen bracket iron hook	2-3

13	Front block	1
14	Front pressing block	1

2.3.5 BladeRest

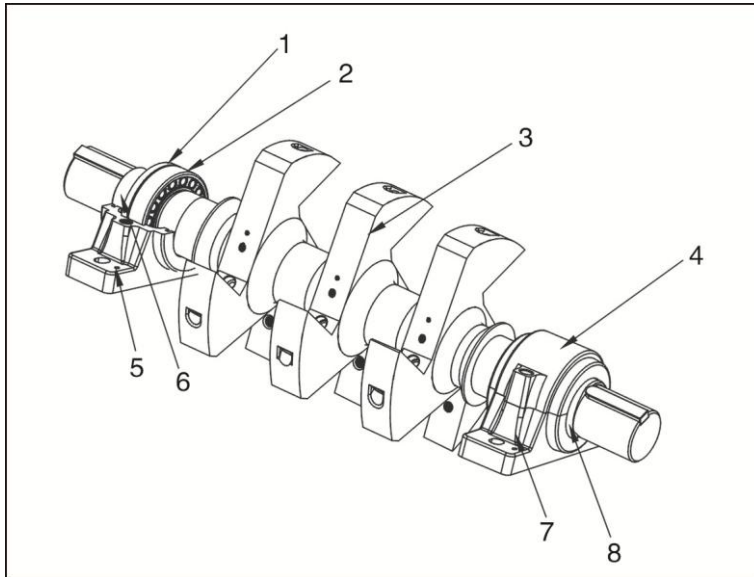

Picture 2-9: BladeRest

2.3.5.1 BladeRest Parts List

Chart 2-3: BladeRest Parts List

No.	Name	Quantity
1	Bearing thrust ring	2
2	Bearing 22215EAE4	2
3	Knife shaft	1
4	Bearing the upper	2
5	Position localized bolt	4
6	Shaft sleeve	2
7	Housings nakedness	2
8	Oil seal TSN215G	4

2.3.6 Transmission Parts

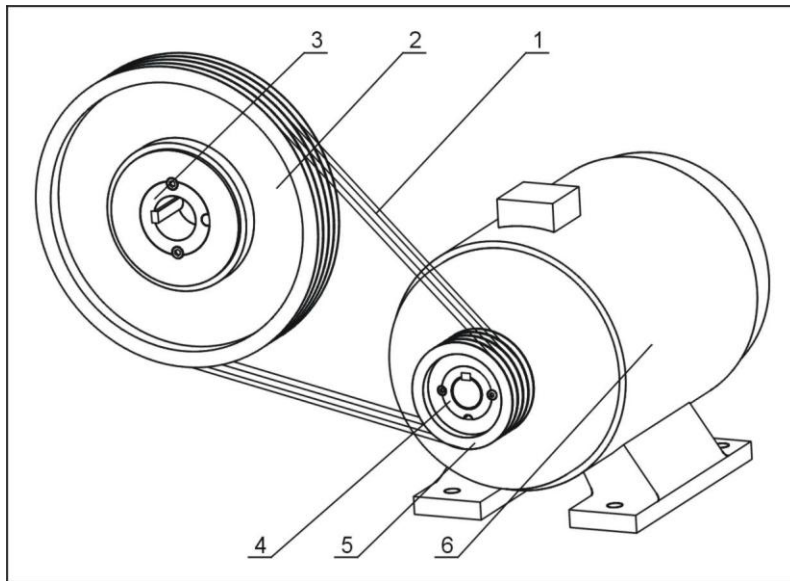

Picture 2-10: Transmission Parts

2.3.7 Transmission Parts List

Chart 2-4: Transmission Parts Parts List

No.	Name	Quantity
1	V belt	4
2	Big belt pulley SPB500X4	1
3	Taper sleeve 3535 ϕ 75	1
4	Taper sleeve 2517 ϕ 55	1
5	Small belt pulley SPB180X4	1
6	Motor	1

2.3.8 Screen

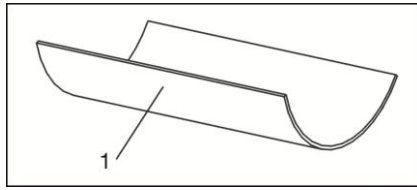

Picture 2-11: Screen

2.3.9 Screen Parts List

Chart 2-5: Screen Parts List

No.	Name	Quantity
1	Screen	1

2.3.10 Screen Bracket

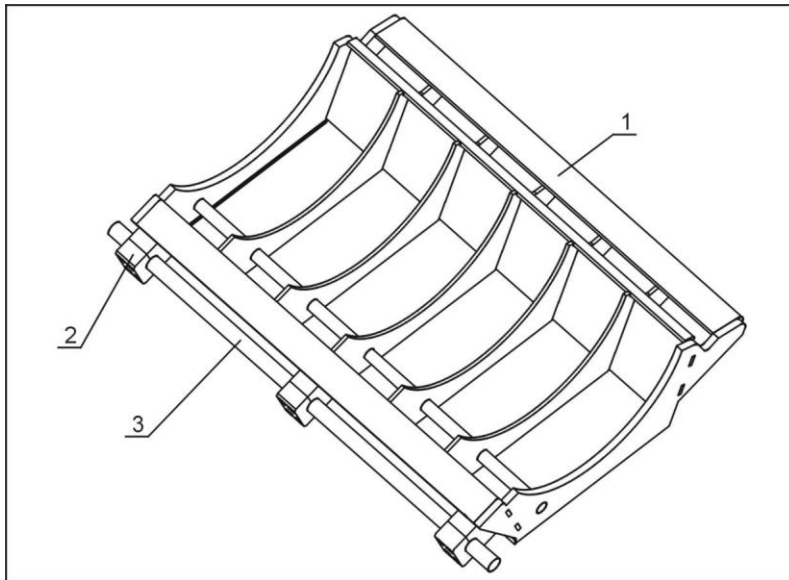

Picture 2-12: Screen Bracket

2.3.11 Screen Bracket Parts List

Chart 2-6: Screen Bracket Parts List

No.	Name	Quantity
-----	------	----------

1	Screen bracket	1
2	Screen bracket shaft pin press plate	2-3
3	Screen bracket shaft pin	1

2.3.12 Blower

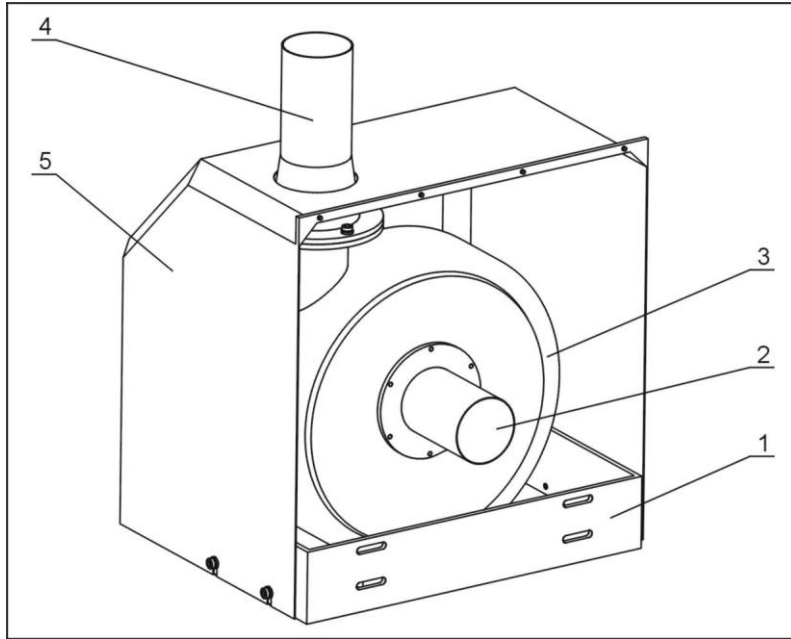

Picture 2-13: Blower

2.3.13 Blower Parts List

Chart 2-7: Blower Parts List

No.	Name	Quantity
1	Blower stents	1
2	Side cover over	1
3	Blower	1
4	Blower flange and take over	1
5	Blower cover	1

2.3.14 Feed Box, Insulative Box and Shutter

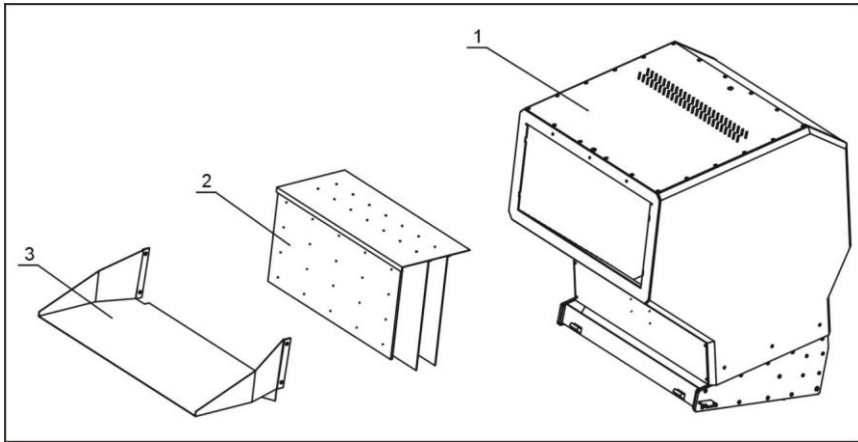

Picture 2-14: Feed Box, Insulative Box and Shutter

2.3.15 Feed Box, Insulative Box and Shutter Parts List

Chart 2-8: Feed Box, Insulative Box and Shutter Parts List

No.	Name	Quantity
1	Feed box	1
2	Material fender	1
3	Feed opening	1

2.3.16 Storage box

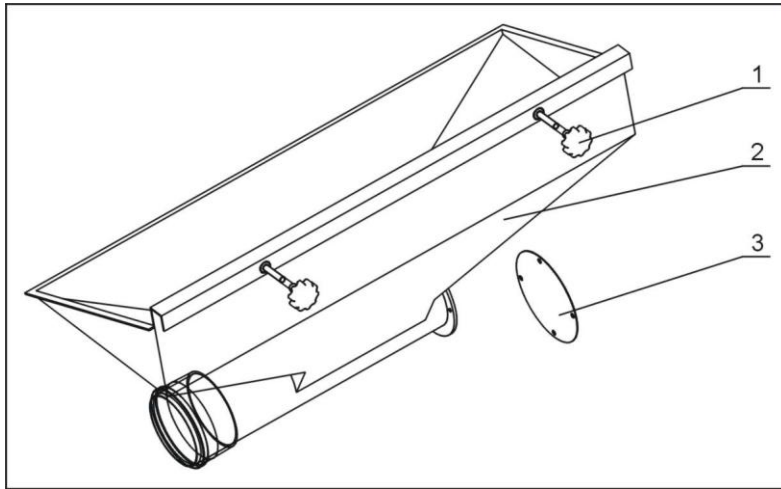

Picture 2-15: Storage box

2.3.17 Storage box Parts List

Chart 2-9: Storage box Parts List

No.	Name	Quantity
1	Five-star handle B typeM8 X35	2
2	Storage box	1
3	Flange	1

2.3.18 Main Body

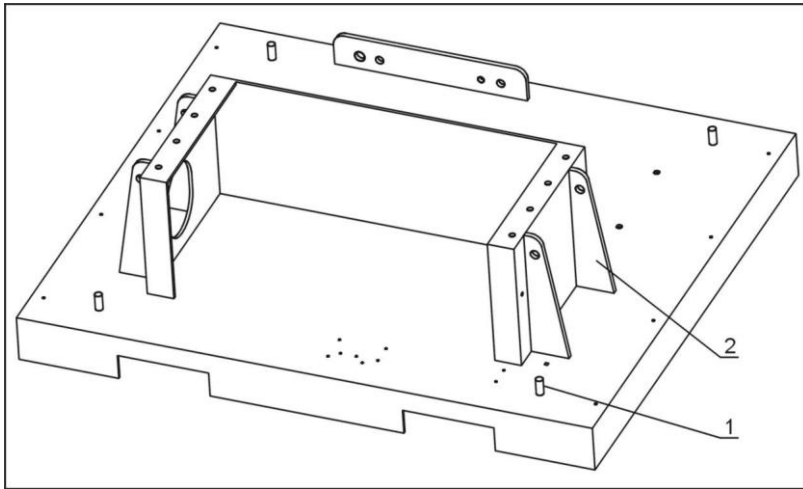

Picture 2-16: Main Body

2.3.19 Main Body Parts List

Chart 2-10: Main Body Parts List

No.	Name	Quantity
1	Anti-vibration pad screw shaft	4
2	Base	1

2.4 Wiring Diagram

2.4.1 Main Circuit (400V)

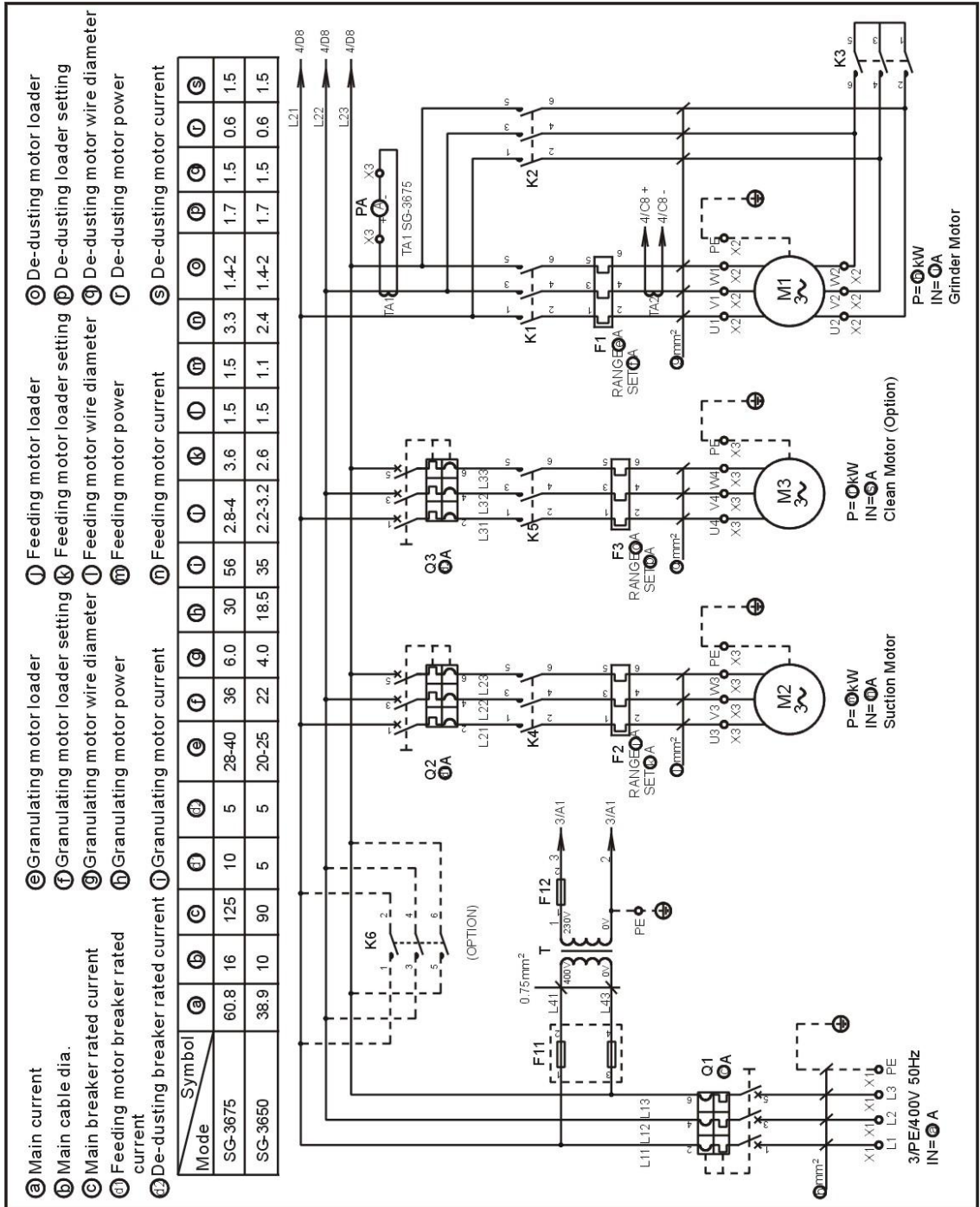

Picture 2-17: Main Circuit (400V)

2.4.2 Control Wiring Diagram (400V)

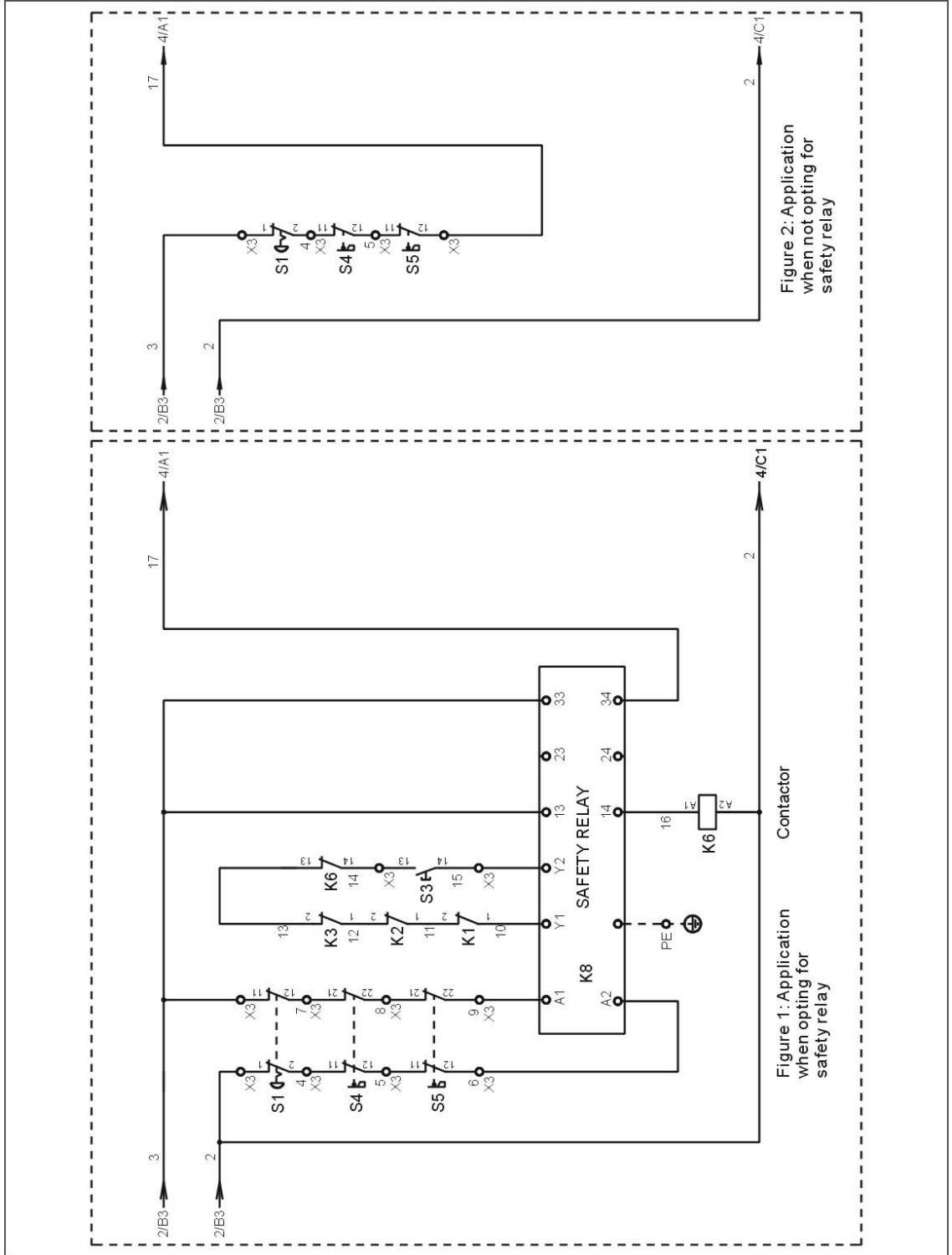
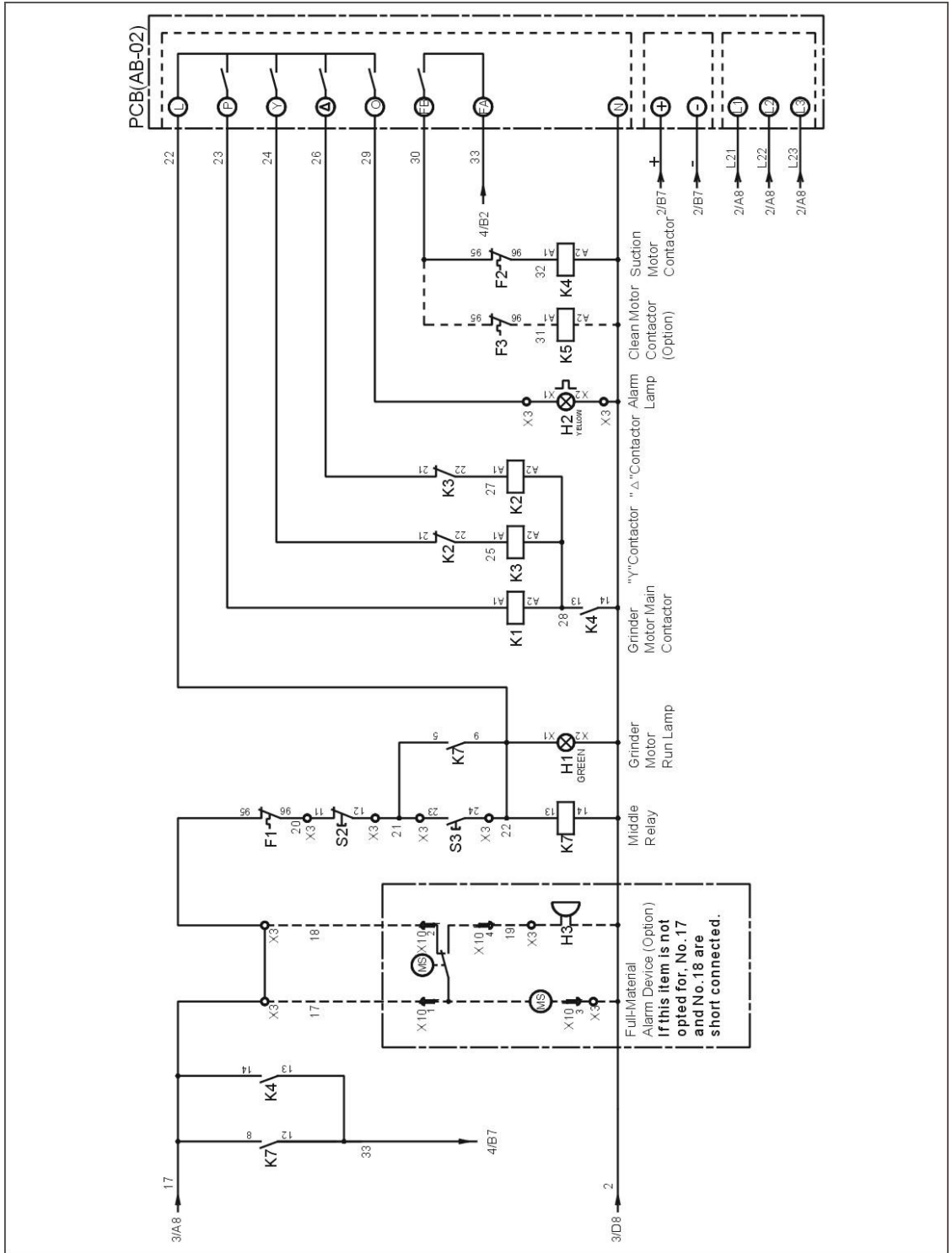

Figure 2: Application when not opting for safety relay

Figure 1: Application when opting for safety relay

Picture 2-18: Control Wiring Diagram 1 (400V)



Picture 2-19: Control Wiring Diagram 2 (400V)

2.4.3 Electrical Components Layout (400V)

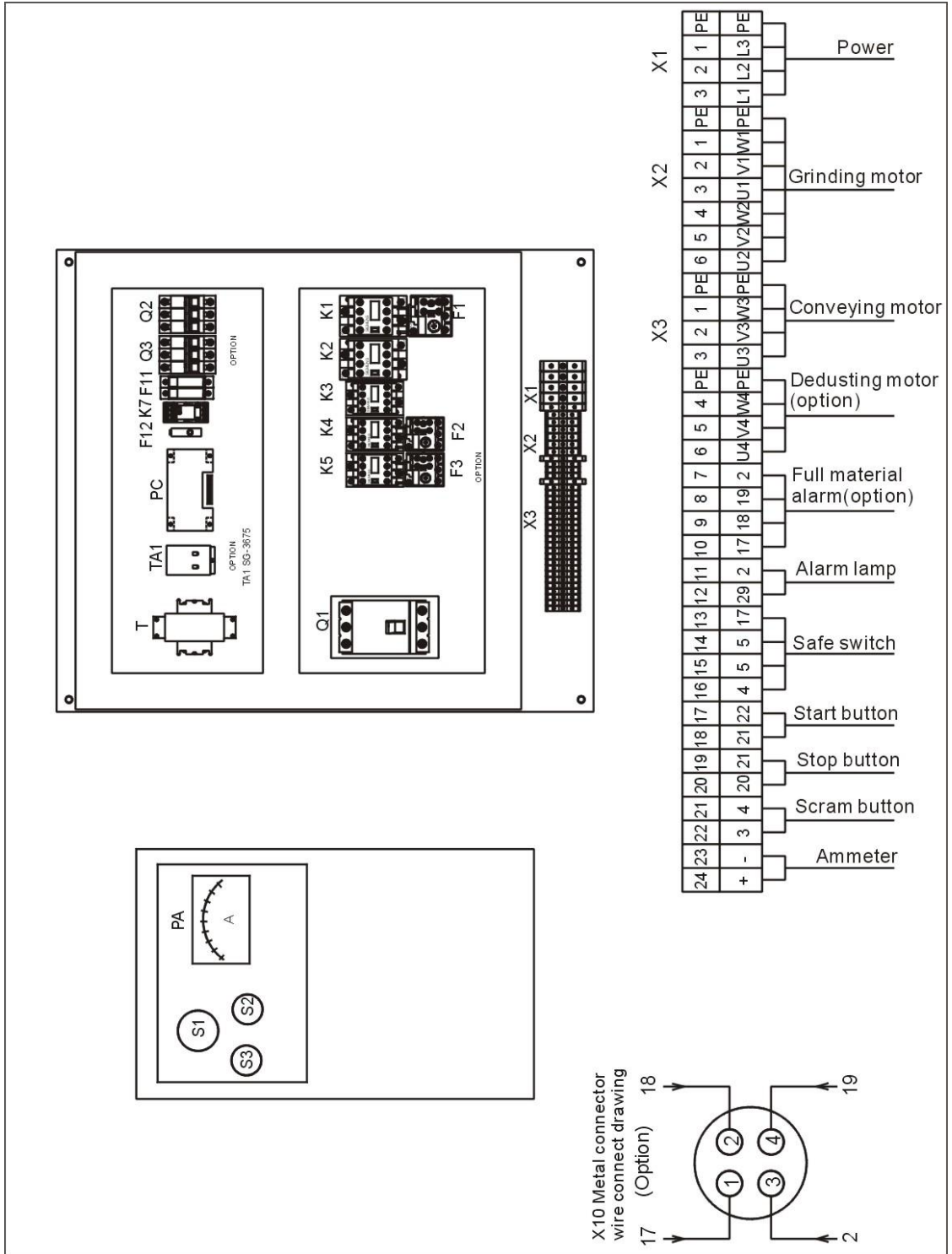

Picture 2-20: Electrical Components Layout (Not Opt For Safety Relay) (400V)

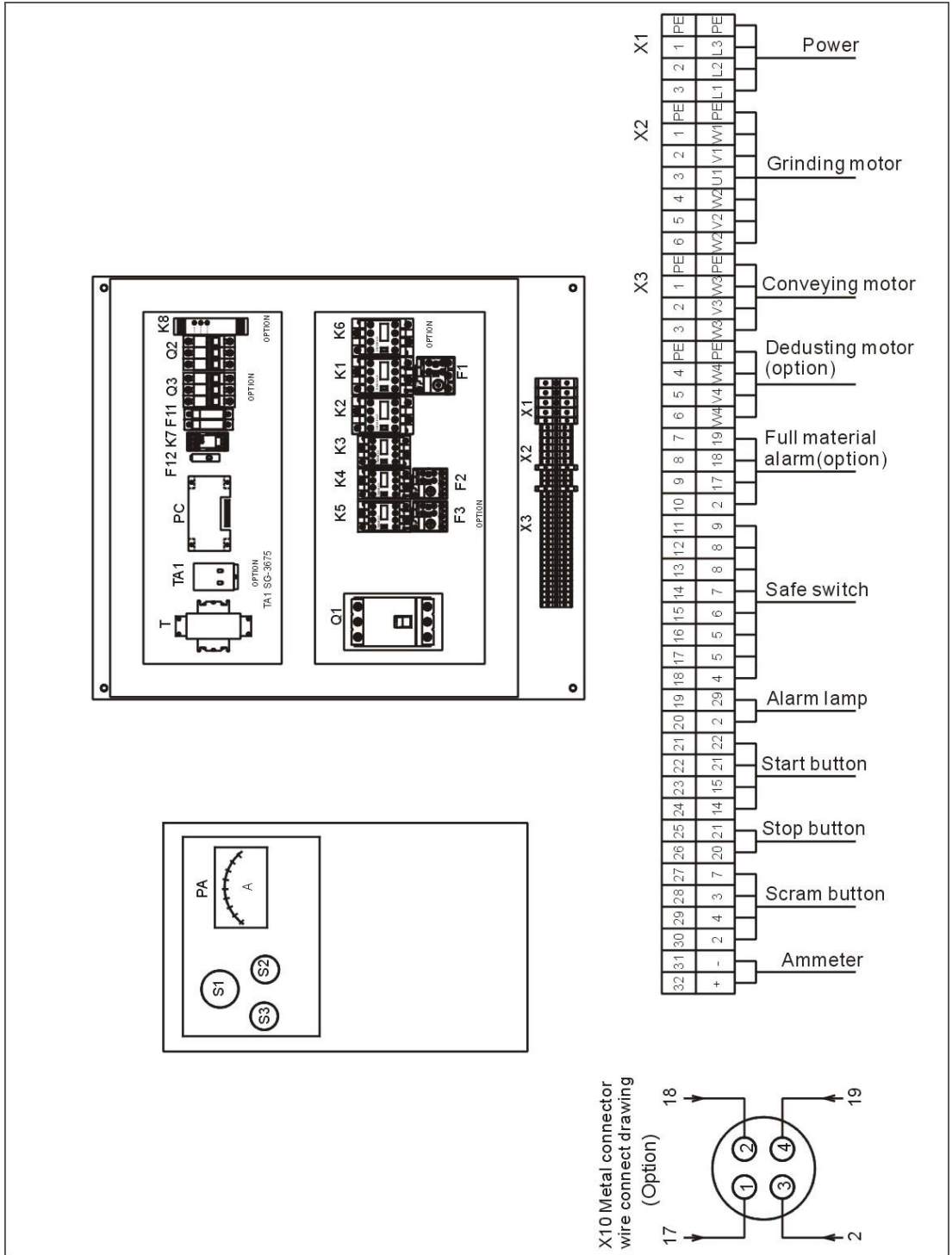

Picture 2-21: Electrical Components Layout (Opt For Safety Relay) (400V)

2.4.4 Electrical Components List (400V)

Chart 2-11: Electrical Components List of SG-3650(400V)

NO.	Symbol	Name	Specification	Part NO.
1	Q1	Gate circuit breaker	90A	YE41109000000
2	Q2	Circuit breaker	5A	YE40603000000
3	Q3	Circuit breaker	5A	YE40603000000
4	K1	Contact ^o r**	220VAC 50/60Hz	YE00602722000
5	K2	Contact ^o r**	220VAC 50/60Hz	YE00602722000
6	-	Auxiliary contact ^o r	1NO+1NC	YE00691100100
7	K3	Contact ^o r**	220VAC 50/60Hz	YE00602622000
8	-	Auxiliary contact ^o r	1NO+1NC	YE00691100100
9	K4	Contact ^o r**	220VAC 50/60Hz	YE00601521000
10	-	Auxiliary contact ^o r	1NO	YE00691110000
11	K5	Contact ^o r**	220VAC 50/60Hz	YE00601521000
12	K6	Contact ^o r**	220VAC 50/60Hz	YE00503500000
13	-	Auxiliary contact ^o r	1NC	YE00592110100
14	K7	Middle relay	220VAC	YE03270700000
15	K8	Safety relay	220VAC	YE04372100000
16	F1	Overload relay	20~25A	YE01260200000
17	F2	Overload relay	2.2~3.2A	YE01160220000
18	F3	Overload relay	1.4~2A	YE01160140000
19	F11	Fuse**	32A	YE41032200000
20	-	Fuse**	1A	YE46001000100
21	F12	Fuse core**	2A	YE41001000000
22	T	Transformer	500mA	YE70402300800
23	X1	Terminal	10mm ²	YE61100000000
24	-	-	10mm ² PE	YE61103500000
25	X2	Terminal	4mm ²	YE61040000000
26	-	-	4mm ² PE	YE61043500000
27	X3	Terminal	6mm ²	YE61060000000
28	-	-	2.5mm ²	YE61250040000
29	-	-	2.5mm ² PE	YE61253500000
30	-	-	2.5mm ²	YE61250040000
31	-	-	2.5mm ² PE	YE61253500000
32	-	-	2.5mm ²	YE61250040000

33	-	-	2.5mm ²	YE61250040000
34	X10	Metal tie in	4P	YE68025400000 YE68025400100
35	PCB	PCB	220VAC	YE80022200100
36	S1	Emergency stop button	400VAC	YE11411000000
37	-	Contact block	1NC	YE19001000100
38	S2	Stop button	400VAC	YE11113100000
39	S3 H1	Start button	400VAC	YE11100100000
40	S3 H1	Start button	400VAC	YE11142100000
41	S4 S5	Safety switch	AZ-15	YE16147600100
42	S4 S5	Safety switch	AZ-16	YE16147600000
43	H2	Alarm lamp	220VAC	YE83305100200
44	H3	Buzzer	220VAC	YE84222000000
45	MS	Feed position motor	220VAC	YE15000200100
46	TA2	Current mutual inductance	5~100A	-
47	PA	Galvanometry	50A	YE25675000000
48	M1	Granulating motor	400V 50Hz 18.5kW	-
49	M2	Solution blower	400V 50Hz 1.1kW	-
50	M3	Dust blower	400V 50Hz 0.6kW	-

* means possible broken parts.

** means easy broken part. and spare backup is suggested.

Please confirm the version of manual before placing the purchase order to guarantee that the item number of the spare part is in accordance with the real object.

Chart 2-12: Electrical Components List of SG-3675 (400V)

NO.	Symbol	Name	Specification	Part NO.
1	Q1	Gate circuit breaker	125A	YE41161200000
2	Q2	Circuit breaker	10A	YE40600300000
3	Q3	Circuit breaker	5A	YE40603000000
4	K1	-	-	-
5	-	Auxiliary contactor	1NC	YE00592110100
6	-	-	220V 50/60Hz	YE00503500000
7	-	Auxiliary contactor	1NC	YE00592110100
8	-	-	220V 50/60Hz	-
9	-	Auxiliary contactor	1NO+1NC	YE00691100100
10	-	-	220V 50/60Hz	-
11	-	Auxiliary contactor	1NO	YE00691110000
12	-	-	220V 50/60Hz	YE00601521000
13	-	-	220V 50/60Hz	-
14	-	Auxiliary contactor	1NC	YE00592110100
15	K7	Middle relay	220VAC	YE03270700000
16	-	Auxiliary contactor	-	-
17	F1	Overload relay	28~40A	YE01513600100
18	F2	Overload relay	2.8~4A	YE01160280000
19	F3	Overload relay	1.4~2A	YE01160140000
20	F11	Fuse**	32A	YE41032200000
21	-	Fuse**	1A	YE46001000100
22	F12	Fuse core**	2A	YE41001000000
23	T	Transformer	500mA	YE70402300800
24	X10	Metal tie in	4P	YE68025400000
25	-	-	4P	YE68025400100
26	X1	Terminal	16mm ²	YE61160000000
27	-	-	16mm ² PE	YE61163500000
28	X2	Terminal	6mm ²	YE61060000000
29	-	-	6mm ² PE	YE61063500000
30	X3	Terminal	2.5mm ²	YE61250040000
31	-	-	2.5mm ² PE	YE61253500000
32	-	-	2.5mm ²	YE61250040000
33	-	-	2.5mm ² PE	YE61253500000
34	-	-	2.5mm ²	YE61250040000

35	-	-	2.5mm ²	YE61250040000
NO.	Symbol	Name	Specification	Part NO.
36	PCB	PCB	220VAC	YE80022200100
37	S1	Emergency stop button	400VAC	YE11411000000
38	-	Contact block	1NC	YE19001000100
39	S2	Stop button	400VAC	YE111113100000
40	S3 H1	Start button	400VAC	YE11100100000
41	S3 H1	Start button	400VAC	YE11142100000
42	S4 S5	Safety switch	AZ-15	YE16147600100
43	S4 S5	Safety switch	AZ-16	YE16147600000
44	H2	Alarm lamp	220VAC	YE83305100200
45	H3	Buzzer	220VAC	YE84222000000
46	MS	Feed position motor	220VAC	YE15000200100
47	TA1	Current mutual inductance	75/5A	YE04750500000
48	TA2	Current mutual inductance	5~100A	-
49	PA	Galvanometry	75/5A	YE25677500000
50	M1	Granulating motor	400V 50Hz 30kW	-
51	M2	Solution blower	400V 50Hz 1.5kW	-
52	M3	Dust blower	400V 50Hz 0.6kW	-

* means possible broken parts.

** means easy broken part. and spare backup is suggested.

Please confirm the version of manual before placing the purchase order to guarantee that the item number of the spare part is in accordance with the real object.

2.4.5 Main Circuit (230V)

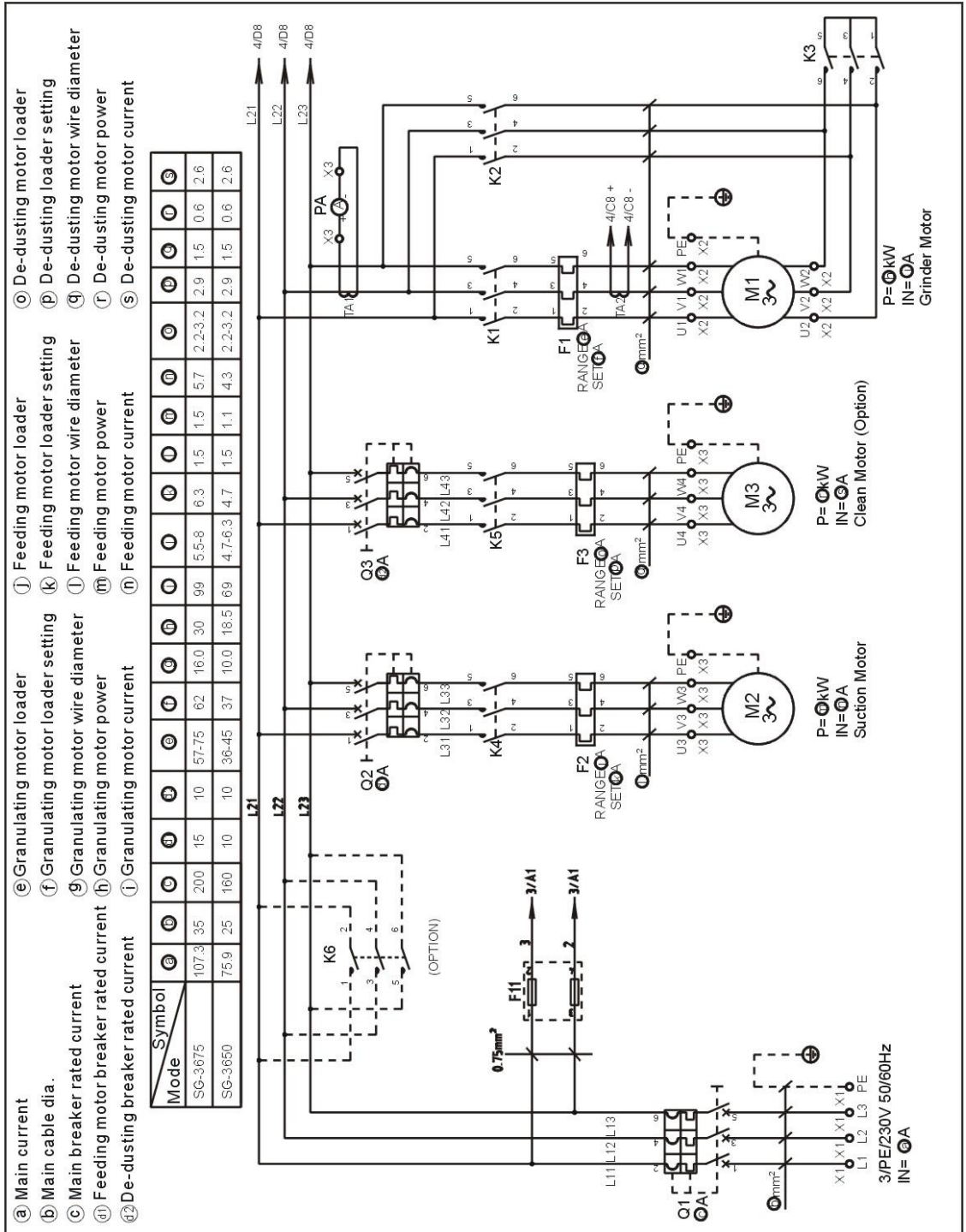

Picture 2-22: Main Circuit (230V)

2.4.6 Control Wiring Diagram (230V)

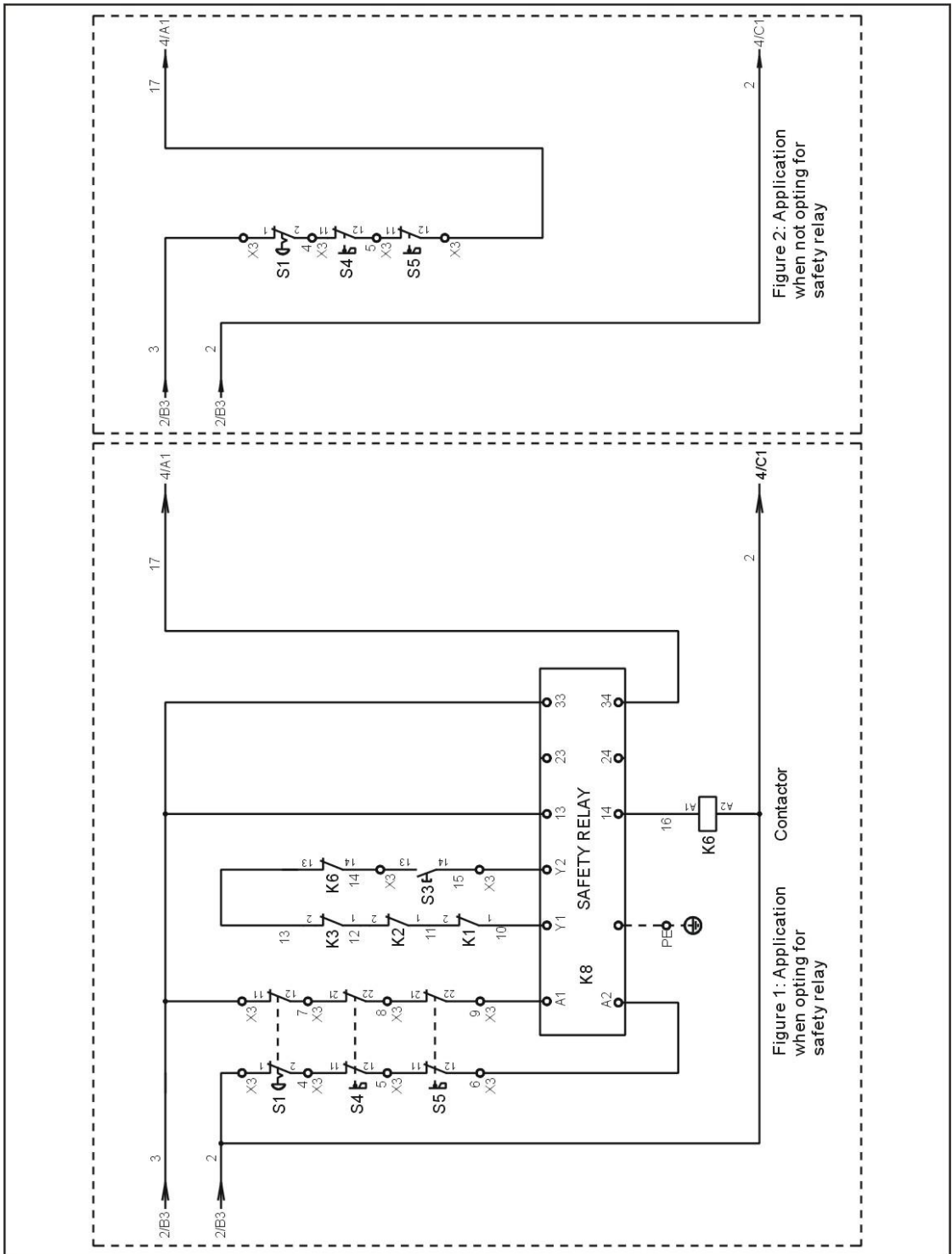

Picture 2-23: Control Wiring Diagram 1 (230V)

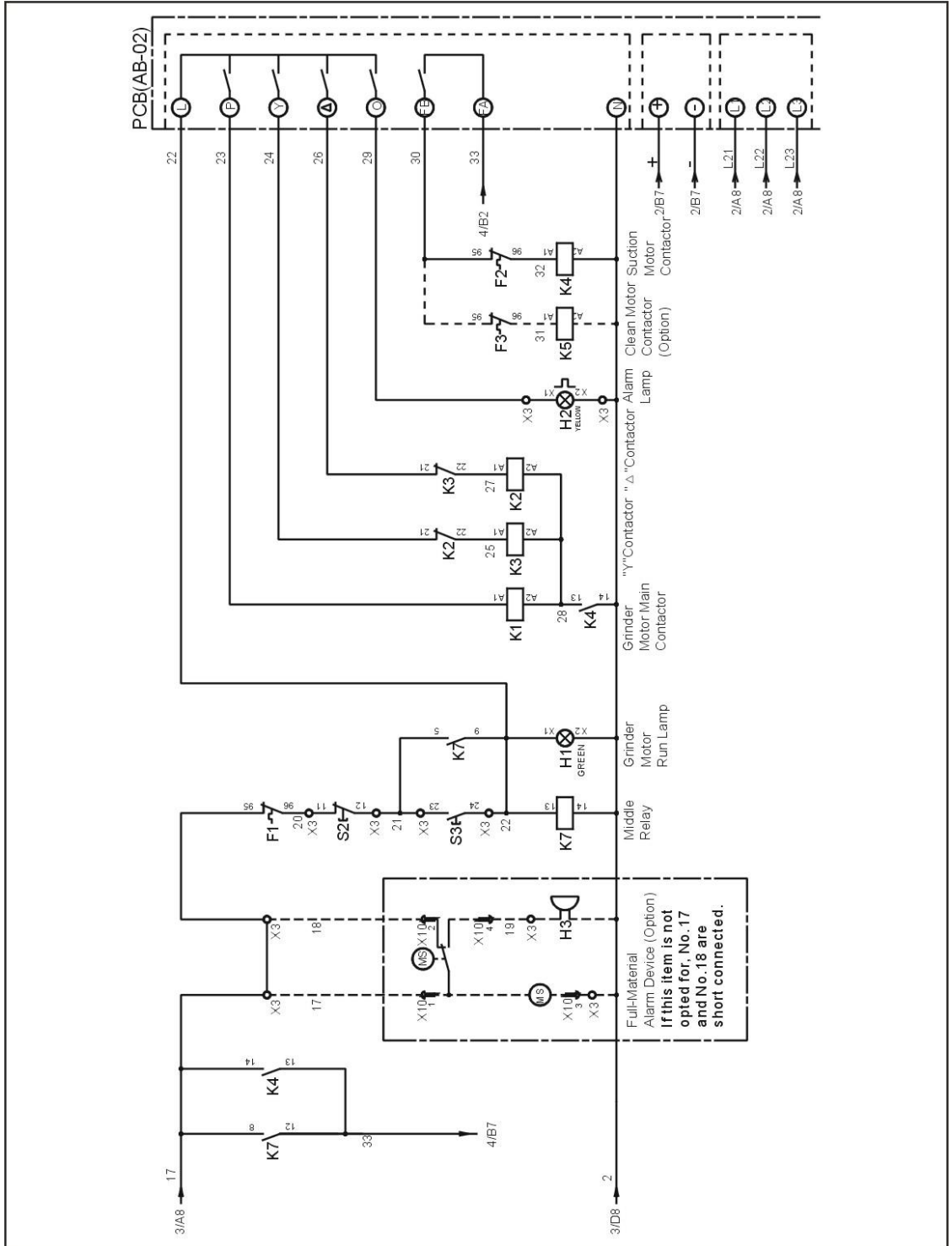

Picture 2-24: Control Wiring Diagram 2 (230V)

2.4.7 Electrical Components Layout (230V)

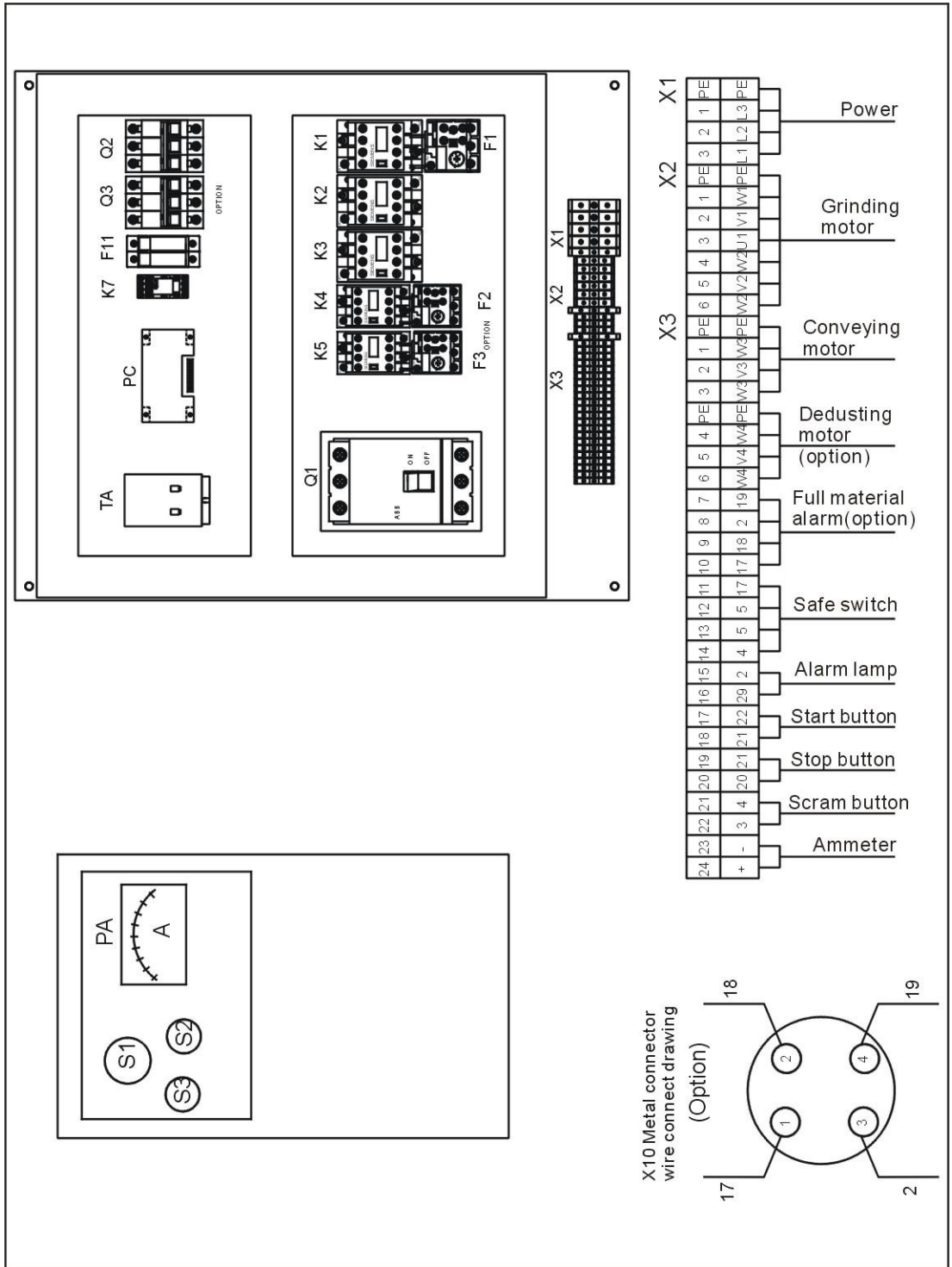

Picture 2-25: Electrical Components Layout (SG-3675 Not Opt For Safety Relay) (230V)

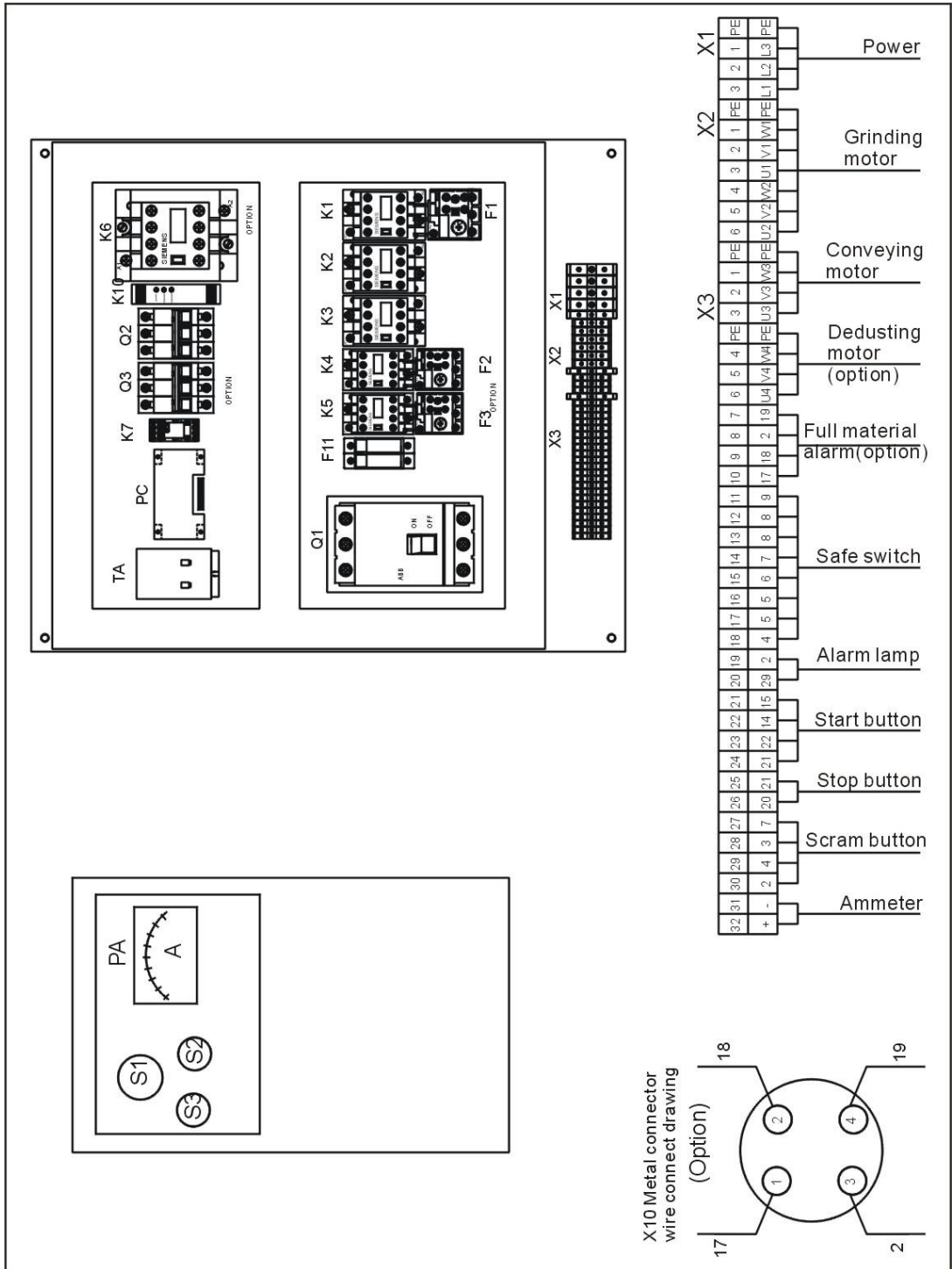

Picture 2-26: Electrical Components Layout (SG-3675 Opt For Safety Relay) (230V)

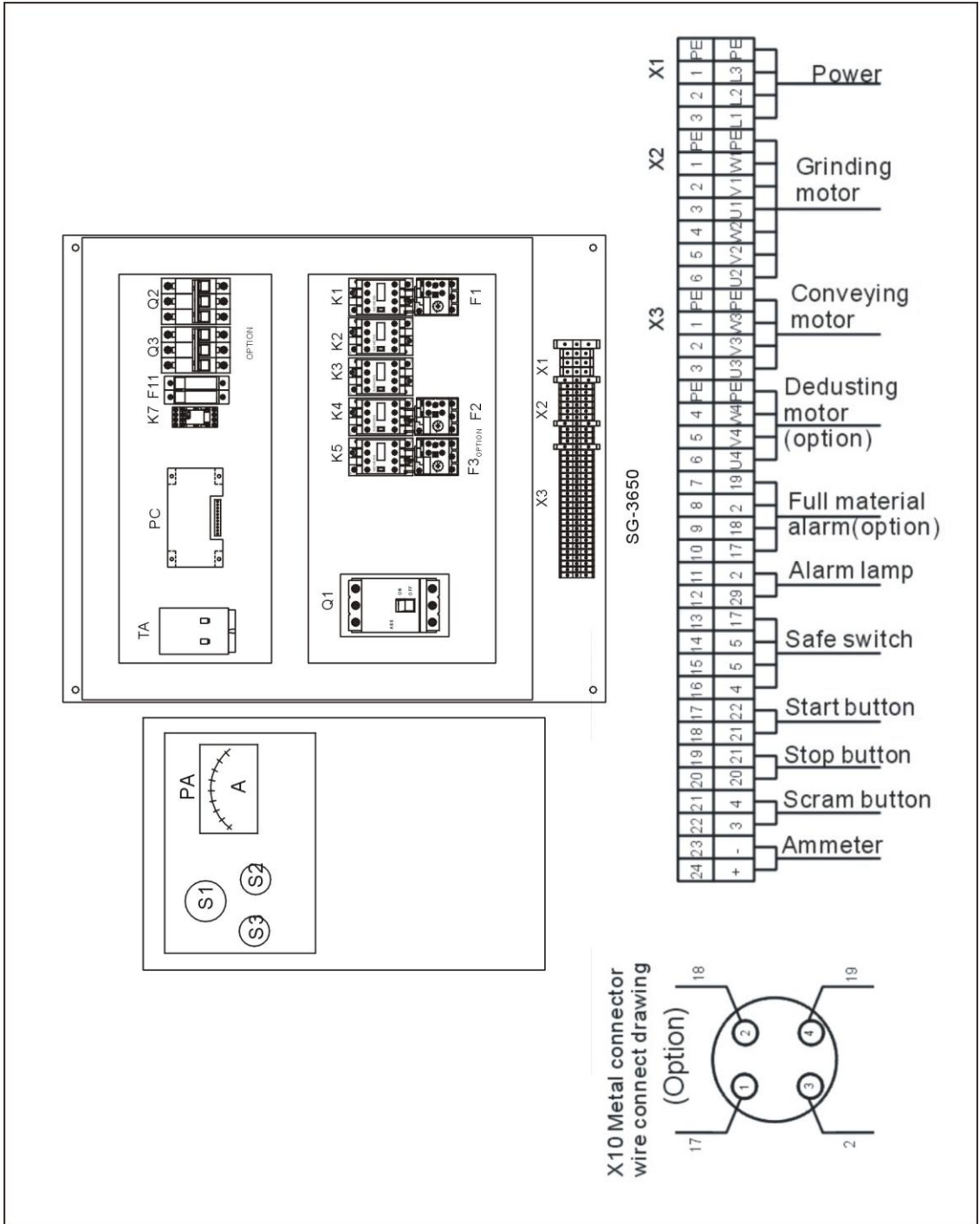

Picture 2-27: Electrical Components Layout (Not Opt For Safety Relay) (230V)

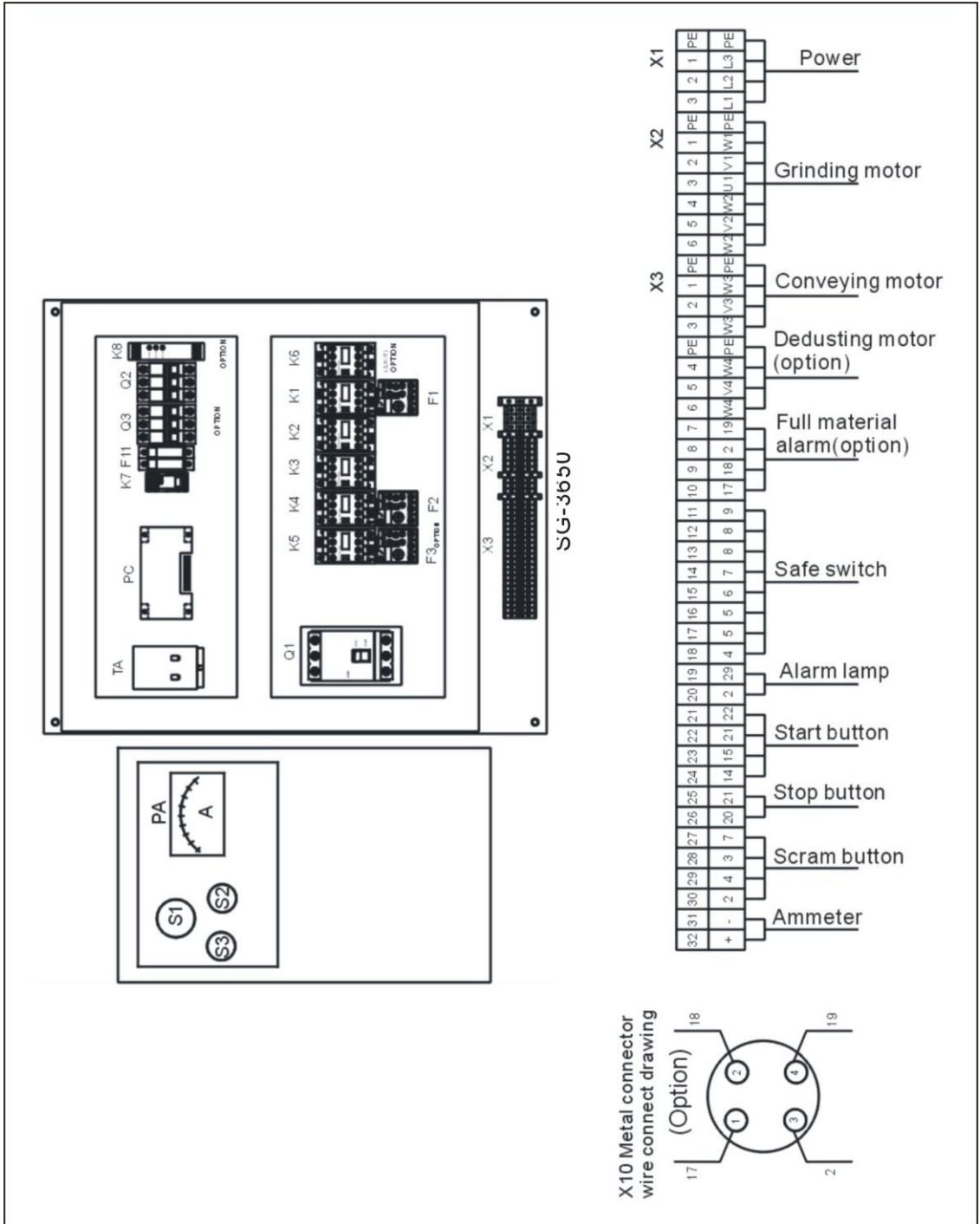

Picture 2-28: Electrical Components Layout (Opt For Safety Relay) (230V)

2.4.8 Electrical Components List (230V)

Chart 2-13: Electrical Components List of SG-3650(230V)

NO.	Symbol	Name	Specification	Part NO.
1	Q1	Gate circuit breaker	160A	YE41161600000
2	Q2	Circuit breaker	10A	YE40603000000
3	Q3	Circuit breaker	10A	YE40603000000
4	K1	Contact ^o r**	220VAC 50/60Hz	YE00503600000
5	-	Auxiliary contact ^o r	1NC	YE00592110100
6	K2	Contact ^o r**	220VAC 50/60Hz	YE00503600000
7	-	Auxiliary contact ^o r	1NC	YE00592110100
8	-	Auxiliary contact ^o r	1NC	YE00592110100
9	K3	Contact ^o r**	220VAC 50/60Hz	YE00503500000
10	-	Auxiliary contact ^o r	1NC	YE00592110100
11	-	Auxiliary contact ^o r	1NC	YE00592110100
12	K4	Contact ^o r**	220VAC 50/60Hz	YE00601521000
13	-	Auxiliary contact ^o r	1NO	YE00691110000
14	K5	Contact ^o r**	220VAC 50/60Hz	YE00601521000
15	K6	Contact ^o r**	220VAC 50/60Hz	YE00504500000
16	-	Auxiliary contact ^o r	1NC	YE00592110100
17	K7	Middle relay	220VAC	YE03270700000
18	K8	Safety relay	220VAC	YE04372100000
19	F1	Overload relay	36~45A	YE01612660000
20	F2	Overload relay	4.7~6.3A	YE01160450000
21	F3	Overload relay	2.2~3.2A	YE01160220000
22	F11	Fuse**	2P	YE41032200000
23	-	Fuse core**	2A	YE46002000100
24	X1	Terminal	35mm ²	YE61350040000
25	-	-	35mm ² PE	YE61353500000
26	X2	Terminal	10mm ²	YE61100000000
27	-	-	10mm ² PE	YE61103500000
28	X3	Terminal	2.5mm ²	YE61250040000
29	-	-	2.5mm ² PE	YE61253500000
30	-	-	2.5mm ²	YE61250040000
31	-	-	2.5mm ² PE	YE61253500000
32	-	-	2.5mm ²	YE61250040000

32	-	-	2.5mm ²	YE61250040000
NO.	Symbol	Name	Specification	Part NO.
34	S1	Emergency stop button	400VAC	YE11411000000
35	-	Contact block	1NC	YE19001000100
36	S2	Stop button	400VAC	YE11113100000
37	S3 H1	Start button	400VAC	YE11100100000
38	S3 H1	Start button	400VAC	YE11142100000
39	S4 S5	Safety switch	AZ-15	YE16147600100
40	S4 S5	Safety switch	AZ-16	YE16147600000
41	H2	Alarm lamp	220VAC	YE83305100200
42	H3	Buzzer	220VAC	YE84222000000
43	MS	Feed position motor	220VAC	YE15000200100
44	TA1	Current mutual inductance	100/5A	YE04100500000
45	TA2	Current mutual inductance	5~100A	-
46	PA	Galvanometry	100/5A	YE25671000000
47	X10	Metal tie in	4P	YE68025400000
48	-	-	4P	YE68025400100
49	PCB	PCB	220VAC	YE80022200100
50	M1	Granulating motor	230V 60Hz 18.5kW	-
51	M2	Solution blower	230V 60Hz 1.1kW	-
52	M3	Dust blower	230V 60Hz 0.6kW	-

* means possible broken parts.

** means easy broken part. and spare backup is suggested.

Please confirm the version of manual before placing the purchase order to guarantee that the item number of the spare part is in accordance with the real object.

Chart 2-14: Electrical Components List of SG-3675 (230V)

NO.	Symbol	Name	Specification	Part NO.
1	Q1	Gate circuit breaker	200A	YE41252000000
2	Q2	Circuit breaker	15A	YE40601500000
3	Q3	Circuit breaker	10A	YE40600300000
4	K1	Contact ^{**}	220VAC 50/60Hz	YE00504500000
5	-	Auxiliary contactor	1NC	YE00592110100
6	K2	Contact ^{**}	220VAC 50/60Hz	YE00504500000
7	-	Auxiliary contactor	1NC	YE00592110100
8	-	Auxiliary contactor	1NC	YE00592110100
9	K3	Contact ^{**}	220VAC 50/60Hz	YE00504400000
10	-	Auxiliary contactor	1NC	YE00592110100
11	-	Auxiliary contactor	1NC	YE00592110100
12	K4	Contact ^{**}	220VAC 50/60Hz	YE00601521000
13	-	Auxiliary contactor	1NO	YE00691110000
14	K5	Contact ^{**}	220VAC 50/60Hz	YE00601521000
15	K6	Contact ^{**}	220VAC 50/60Hz	YE00505400000
16	K7	Middle relay	220VAC	YE03270700000
17	K8	Safety relay	220VAC	YE04372100000
18	F1	Overload relay	57~75A	YE01514650000
19	F2	Overload relay	5.5~8A	YE01160550000
20	F3	Overload relay	2.2~3.2A	YE01160220000
21	F11	Fuse ^{**}	2P	YE41032200000
22	-	Fuse core ^{**}	2A	YE46002000100
23	X1	Terminal	35mm ²	YE61350040000
24	-	-	35mm ² PE	YE61353500000
25	X2	Terminal	16mm ²	YE61160000000
26	-	-	16mm ² PE	YE61163500000
27	X3	Terminal	2.5mm ²	YE61250040000
28	-	-	2.5mm ² PE	YE61253500000
29	-	-	2.5mm ²	YE61250040000
30	-	-	2.5mm ² PE	YE61253500000
31	-	-	2.5mm ²	YE61250040000
32	-	-	2.5mm ²	YE61250040000
33	S1	Emergency stop button	400VAC	YE11411000000
34	-	Contact block	1NC	YE19001000100

35	S2	Stop button	400VAC	YE11113100000
NO.	Symbol	Name	Specification	Part NO.
36	S3 H1	Start button	400VAC	YE11100100000
37	S3 H1	Contact block	400VAC	YE11142100000
38	S4 S5	Safety switch	AZ-15	YE16147600100
39	S4 S5	Safety switch	AZ-16	YE16147600000
40	H2	Alarm lamp	220VAC	YE83305100200
41	H3	Buzzer	220VAC	YE84222000000
42	MS	Feed position motor	220VAC	YE15000200100
43	TA1	Current mutual inductance	150/5A	YE04100500000
44	TA2	Current mutual inductance	5~100A	-
45	PA	Galvanometry	150/5A	YE25675000000
46	X10	Metal tie in	4P	YE68025400000 YE68025400100
47	M1	Granulating motor	230V 60Hz 30kW	-
48	M2	Solution blower	230V 60Hz 1.5kW	-
49	M3	Dust blower	230V 60Hz 0.6kW	-
50	PCB	PCB	220VAC	YE80022200100

* means possible broken parts.

** means easy broken part. and spare backup is suggested.

Please confirm the version of manual before placing the purchase order to guarantee that the item number of the spare part is in accordance with the real object.

2.5 Electrical Components Instruction

2.5.1 Microprocessor Board (PCB)

Function: 1) "Y" "Δ" reduced voltage starting.

2) Granulating motor overload detection and alarm.

3) Material conveying blower time-delay stop.

4) phase sequence dection, warning and machine halt

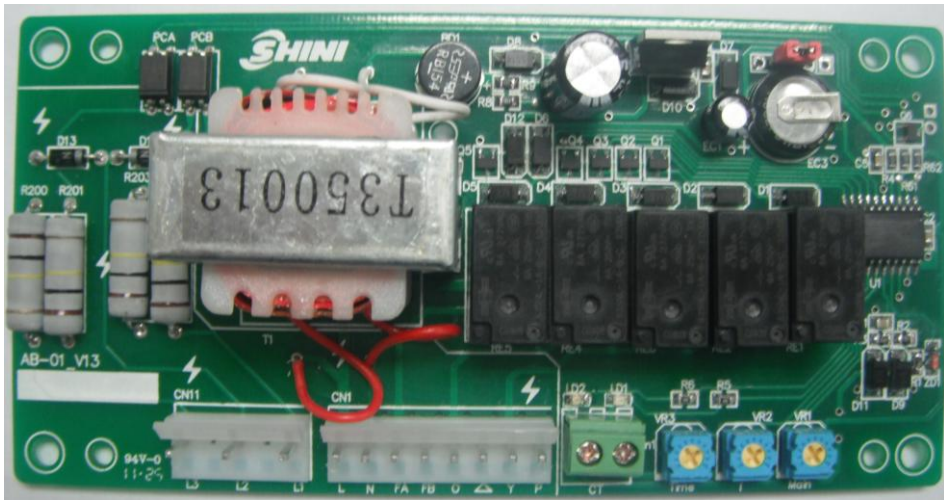

Picture 2-29: PCB

Scale of Variable Resistor 									
Fine Adjustment I(A): VR1	-4	-3	-2	-1	0	+1	+2	+3	+4
Rate Current setting (I): VR3	5A	10A	20A	30A	40A	50A	60A	70A	80A

Scale of Variable Resistor 									
Y ^Δ Start Switching : VR2	3S	6S	9S	12S	15S	19S	22S	24S	30S

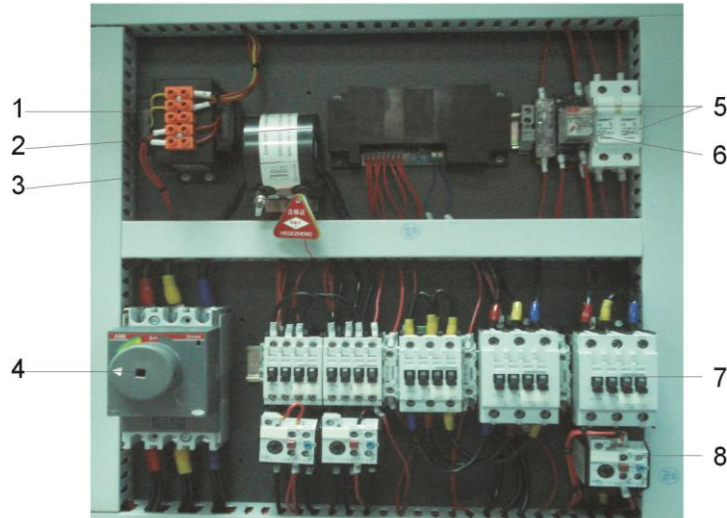

Picture 2-30: Electrical Components Description

1. Transformer, which supplies proper voltage for control circuit.
2. PCB which controls the start and stop of the machine.
3. Current transformer, which induces current.
4. Circuit breaker, which can perform the function of circuit protection.
5. Fuse, which performs the function of overloading protection and short circuit protection.
6. Intermediate relay, which performs the function of switch and connection of contact point.
7. Electromagnetic contactor, which can connect or cut off the circuit from remote.
8. Thermo overload relay, which can protect the motor when overloading or open phase.

2.6 Optional Accessories

2.6.1 DS-36 Dust separate System

2.6.1.1 Installation illustrative Photo

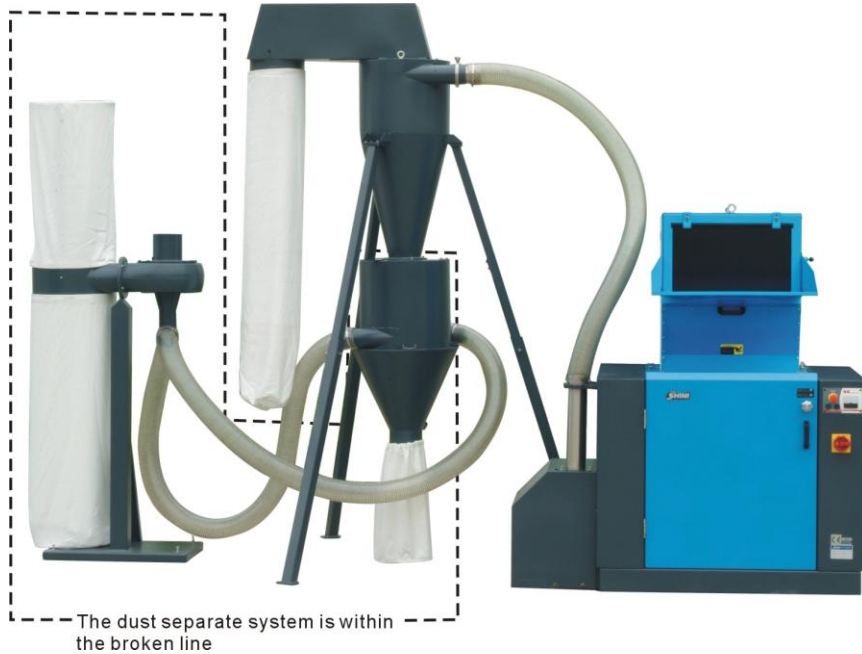

Picture 2-31: Installation illustrative Photo

2.6.1.2 Outline Dimensions

Outline Dimensions ($\Phi \times h$).....600×1030mm

Dust collecting device ($l \times w \times h$) 920×500×2610mm

Fittings	Quantity	Note
Cyclone separator	1 piece	-
Dust separator	1 piece	-
Wind machine housing	1 piece	-
Stainless steel pipe (long one)	1 piece	-
Pipe Clip 5"	6 piece	-
Hop-pocket (two ends are opening)	1 piece	With cotton
Filtering hop-pocket	1 piece	-

Dust collection hop-pocket	2 piece	With cotton
Fittings	Quantity	Note
Fixing bracket for cyclone dust separator	Upper 3 items Lower 3 items	-
Loth bag bracket	1 piece	-
Multi-thread plastic pipe 4"×3m	3 piece	-
Locking fittings	2 piece	-

2.6.1.3 Installation



Read chapter 3 carefully before operating on dust separate system the circuit connection of the system should be done by professional electrician.

Before first startup

The unpainted parts of the machine are protected with oil prior to delivery and transport. Clean the granulator from rust protection agent before it is used.

Connection

- 1) Place a separator under cyclone device, the diameter is $\Phi 250\text{mm}$.
- 2) Connect to conveying pipe, the diameter is 4 inches×2.
- 3) Mount dust collection device including air and dust separate bags.
- 4) Place a container under the separator to help collecting plastic material after dust removing



Notes!

If use cloth bag to connect the separator, please make sure a good ventilation within the cloth bag.

2.6.1.4 Operation and maintenance

Start and stop of the machine

Start and stop of the machine is controlled by main power switch.

2.6.1.5 Check

Daily check

Air and dust bags, check if these bags are damaged, if there is any damage, please replace them.

Check if the conveying pipe is damaged, if it is, please replace it.

Check if the connecting joint had been fixed and sealed.

Check if the dust collection bag is full, if it is, please dump it. Check if the collection barrel is placed right under the dust separator, if there has any deviation, please adjust it.

Check the collection barrel, if it is full, take out the dust removed plastic in time.

Weekly check

Check to see if the wire has any damage and the condition of the wire, if it has any problem, please fix it.

2.6.2 Clean



Notes!

Clean the machine when the processing material is changed or after every 300-hour running time. Before cleaning, please cut off the power.

- 1) First clean the inner side of the cleaning facilitates.
- 2) It is necessary to check and clean dust separator.
- 3) Move away separator, use high pressure air to blow away its interior granules.
- 4) Clean out the storage hopper and clean its interior.
- 5) Shake the air bag to drop the dust down.
- 6) Assembly the disassembled parts according to reversed order.

2.6.3 Screen



Picture 2-32: Screen

Hole dia. (mm)	Model	
	SG-3650	SG-3675
Φ8	BL55356001320	BL55367503120
Φ12	BL55365001420	BL55367503220
Φ17	BL55365001520	BL55367503320
Φ25	BL55365001620	BL55367503420

Note: Φ10 is standard

2.6.4 Cutters

Material	International code		
	China GB	USA ASTM	Japan JIC
SKD11	Cr12MoV	D2	SKD11

3. Installation and Debugging



Read through this chapter before installation.



Install as following orders to avoid any accident!



Be careful! Not to be cut by the sharp blade.



Power connection must be done by the professional electrician to avoid electrical shock.



Caution!

cutters should be laid level, prevent the cutters from self-rotating when do installation, don't let your hands be near to the cutters to avoid personal injury.



Notice!

Do not install the cutters by working together, because this could bring personal injury. Use a thick wood block to stop the rotating knives from turning.



Notice!

The blades are very sharp, so use protective gloves to avoid being cut.



Notice!

Please use new screws and gaskets when installing cutters.



The power connection of the granulator should be carried out by professional electrician so to avoid electrical shock!

3.1 Installation Notice

- 1) Make sure voltage and frequency of the power source comply with those indicated on the manufacture's plate, which is attached to the machine.
- 2) Power cable and earth connections should conform with local regulations.
- 3) Use independent power cable and ON / OFF switch. The cable's dia. Should not smaller than those applied in the control box.
- 4) The power cable connection terminals should be tightened securely.
- 5) The machine requires a 3-phase 4-wire power source, connect the power lead (L1, L2, L3) to the live wires, and the earth (PE) to the ground.
- 6) Power supply requirements:
 - Main power voltage: +/- 10%
 - Main power frequency: +/- 2%

Make at least 1 meter clearance around the machine to facilitate repair and maintenance.

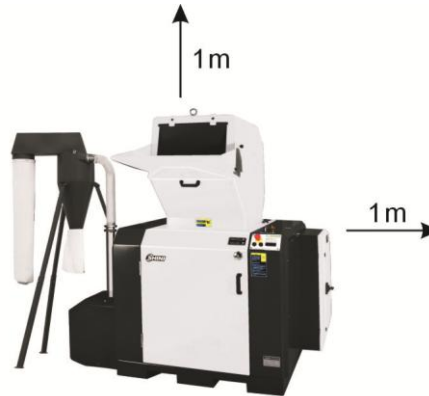

Picture 3-1: Installation Space

Chart 3-1: Attached form, cutters and other fixing screw torque

Threading Type	Threading Specification	Stretching Force FV (N)			Tightening Torque Ma (N.m)		
		Grade -8.8	Grade -10.9	Grade -12.9	Grade -8.8	Grade -10.9	Grade -12.9
Coarse Thread	M4	3900	5750	6700	3.0	4.4	5.1
	M5	6400	9400	11000	5.9	8.7	10
	M6	9000	1320	15500	10	16	18
	M8	16500	24300	28400	25	36	43
	M10	26300	38700	45200	49	72	84
	M12	38400	56500	66000	86	126	145
	M14	62500	77500	90500	135	200	236
	M16	72500	10700	12500	210	310	365
	M18	91000	129000	152000	300	430	600
	M20	117000	166000	195000	425	610	710
	M22	146000	208000	244000	580	820	960
	M24	168000	240000	281000	730	1050	1220
	M27	222000	316000	369000	1100	1550	1800
	M30	269000	384000	449000	1450	2100	2450
Fine Thread	M8×1	18100	26600	31200	27	39	46
	M10×1.25	28300	41600	48700	52	76	90
	M12×1.25	43300	63500	74600	93	135	160
	M12×1.5	40800	60000	70000	89	130	155
	M14×1.5	58600	86000	100000	145	215	255
	M16×1.5	79500	116000	136000	226	330	390
	M18×1.5	108000	152000	177000	340	485	570
	M20×1.5	134000	191000	224000	475	680	790
	M22×1.5	166000	236000	276000	630	900	1050
	M24×2	189000	270000	316000	800	1150	1350
	M27×2	246000	350000	409000	1150	1650	1950
	M30×2	309000	440000	515000	1650	2350	2750

3.2 Installation Place



Make enough installation space to help the repair and maintenance. Check and make sure the installation ground is level, there is enough intensity when it is running.

Use spirit level to adjust the cutting chamber to the level position.

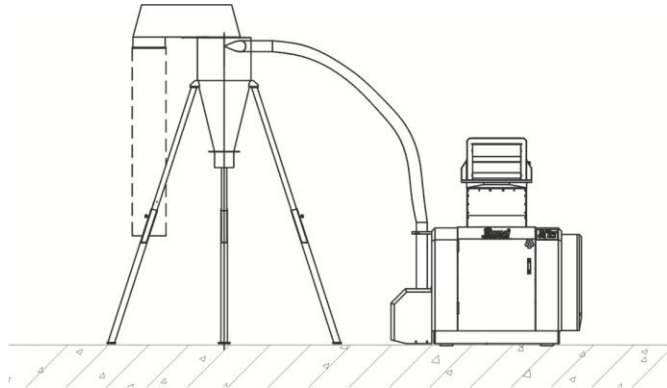

Picture 3-2: Installation Place 1

SG-36 rabbets for forklift to transport.

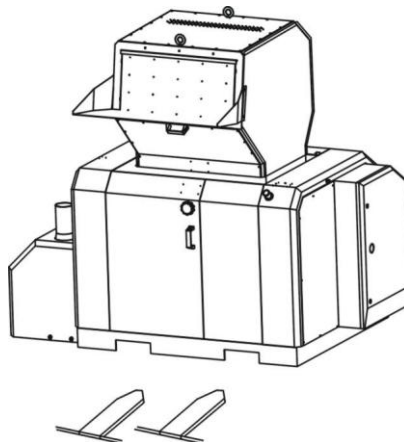

Picture 3-3: Installation Place 2



Please do not install feed box on the mainbody of the granulator, then

hoist them together, or it will cause damage to the machine.

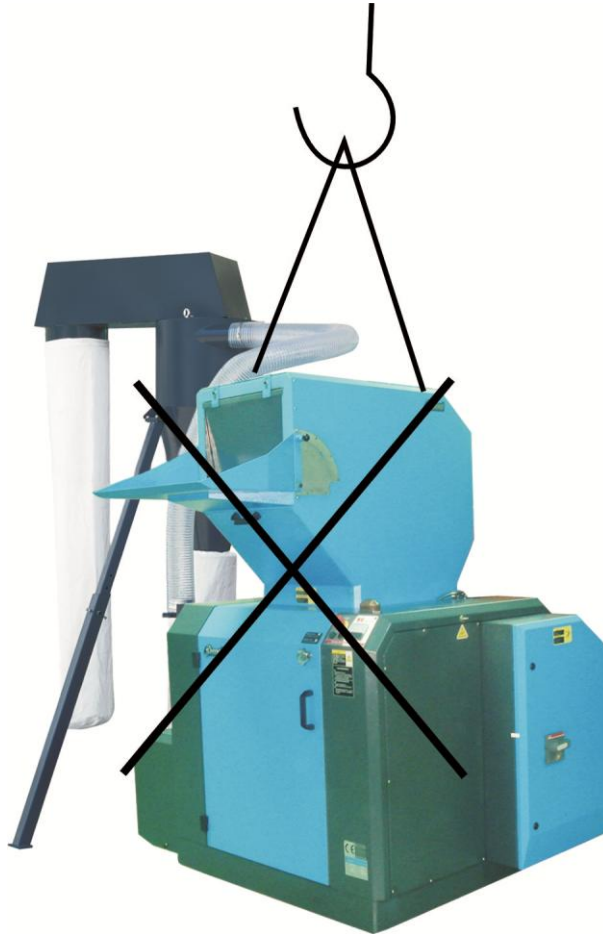

Picture 3-4: Installation Place 3

3.3 Installation of Bearing and Blade Rest

- 1) Heat the bearing and lay it to be entrapped into the blade rest.



Use 120°C kerosene to heat it up for 5 minutes.

- 2) Fix the low half part of bearing base into both right and left sides of table-board, match the positions of the hole and lock them tightly.
- 3) Put the blade rest inside the granulation chamber and make both ends of its bearing to match with the grooves.



Note!

Add some lubricating oil in both bearing and bearing block. Aluminous circlip should be laid between the left bearing and its bearing block.

- 4) Install the shutter ring and bearing cap. Then, lock it up with screws.



Picture 3-5: Installation of Bearing and Blade Rest

3.4 Installation of Belt Pulley and Motor

3.4.1 SG-3650

- 1) Interpose the key to the key groove and then install the driven wheel.



Picture 3-6: Installation of Belt Pulley and Motor 1 (SG-3650)

- 2) Lay lockup ring in the hole of the driven wheel and make both positions of the hole to match each other then screw the hexagon socket cap screw (M12mm×40).
- 3) Adjust the balance of the driven wheel with dial gauge. Stick the dial gauge to the driven wheel and rotate the driven wheel to see whether the value of the indicator drops within 0~0.1 mm.

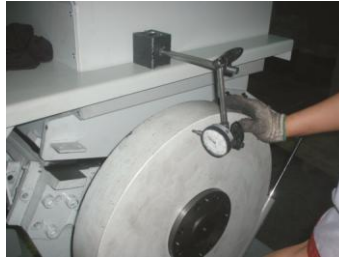

Picture 3-7: Installation of Belt Pulley and Motor 2(SG-3650)

- 4) After balance, screw tightly the 8 hexagon socket cap screws.
- 5) Install the driving wheel in the bearing of the motor and screw the 6 hexagon socket cap screws with the specificity of $\Phi 10\text{mm} \times 35$.
- 6) Lay the motor on the fixing plate to adjust and screw tightly the 4 fixing screws. Push forward to shorten the space between the driving wheel and the driven wheel.



Picture 3-8: Installation of Belt Pulley and Motor 2(SG-3650)

- 7) Adjust the balance of the driving wheel and driven wheel: place spirit level between the driving wheel and the driven wheel to observe whether the mercury column is in the middle. If not, adjust the driving wheel (note: NOT the driven wheel) to make the driven wheel and driving wheel in balance.



Picture 3-9: Installation of Belt Pulley and Motor 2 (SG-3650)

- 8) Install the belt, push the motor rightward and screw tightly the position adjusting bolt to make the 4 belts be stressed by equal forces. Tighten the belts and screw down the position adjusting bolt.

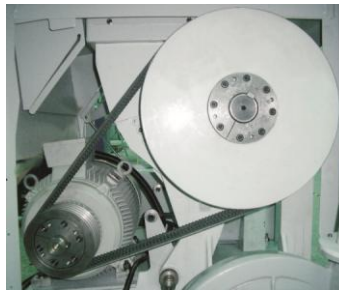

Picture 3-10: Installation of Belt Pulley and Motor 5 (SG-3650)

3.4.2 SG-3675

- 1) Interpose the key to the key groove and then install the driven wheel.



键

Picture 3-11: Installation of Belt Pulley and Motor 1 (SG-3675)

- 2) Lay lockup ring in the hole of the driven wheel and make both positions of the hole to match each other then screw the hexagon socket cap screw (M12mm×40).
- 3) Adjust the balance of the driven wheel with dial gauge. Stick the dial gauge to

the driven wheel and rotate the driven wheel to see whether the value of the indicator drops within 0~0.1 mm.

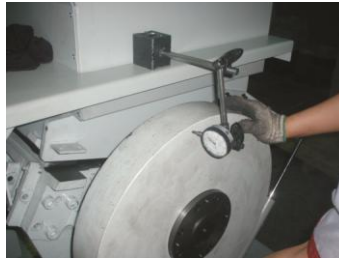

Picture 3-12: Installation of Belt Pulley and Motor 2 (SG-3675)

- 4) After balance, screw tightly the 8 hexagon socket cap screws.
- 5) Install the driving wheel in the bearing of the motor and screw the 6 hexagon socket cap screws with the specificity of $\Phi 10\text{mm} \times 35$.
- 6) Lay the motor on the fixing plate to adjust and screw tightly the 4 fixing screws. Push forward to shorten the space between the driving wheel and the driven wheel.
- 7) Adjust the balance of the driving wheel and driven wheel: place spirit level between the driving wheel and the driven wheel to observe whether the mercury column is in the middle. If not, adjust the driving wheel (note: NOT the driven wheel) to make the driven wheel and driving wheel in balance.



Picture 3-13: Installation of Belt Pulley and Motor 3 (SG-3675)

- 8) Install the belt, push the motor rightward and screw tightly the position adjusting bolt to make the 4 belts be stressed by equal forces. Tighten the belts and screw down the position adjusting bolt.



Picture 3-14: Installation of Belt Pulley and Motor 4 (SG-3675)

3.5 Installation of Fixed Blades and Rotating Blades



WARNING!

Always take great care when handling the knives since they are very sharp and can cause personal injury. Use protective gloves!

Installation steps:

- 1) Lay the rotating blades into the knife groove in the knife rest to make them match and then cover the pressing block. Finally, screw the screws down to make the blade not sway.
- 2) Install the front and back pressing blocks and the fixed blades on the front and back boxes. Screw down the screws until the blade cannot sway anymore.
- 3) Measure the space between the fixed blade and the rotating blade using a steel rule. The normal space ranges from 0.2~0.3 mm. Adjust if the space is not in this range. Screw down the fixing screws between the fixed blade and the rotating blade.



Picture 3-15: Installation of Fixed Blades and Rotating Blades



Caution!

Fixed screws must be tightened to avoid cutting and doing harm to machine.



Caution!

The space between the fixed blade and the rotating blade cannot be too narrow to avoid damaging the cutting tool.

3.6 Installation of Storage box, Screen and Screen Bracket

- 1) Put the screen bracket into the cutting chamber and move backward the screen bracket and fit the spindle into circular arc of the boss, then install the boss pressing plate and tighten the screw.

- 2) Detach the screen bracket and put the screen in it.
- 3) Lift up the screen bracket again and lock it closely with the very front fixing pothook.



Note

Note! The screw must be tightened in this step; otherwise, a deformation will occur in the screen bracket and thus results in the break of the screws.

- 4) Install the storage box. Uplift the storage box and plug the box rear into the grooves of the side plates, push it forward until the end.
- 5) Tighten the star handle on the storage box.

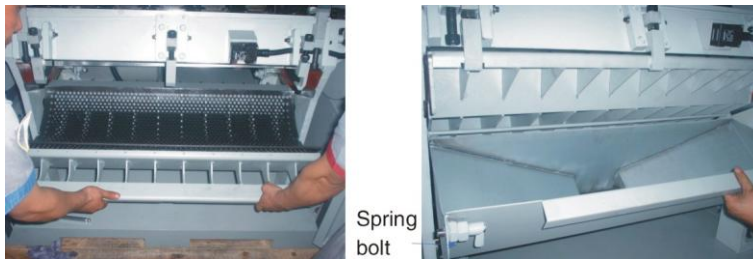

Picture 3-16: Installations of Storage box, Screen and Screen Bracket.

3.7 Installation of Feed Box and Feed Inlet

- 1) Open the front doors and the back cover.
- 2) Hoist the feed box to put it on the cutting chamber carefully to match.



Picture 3-17: Installation of Feed Box and Feed Inletv 1

3) Mount both side location pin and lock up with lockup screw.

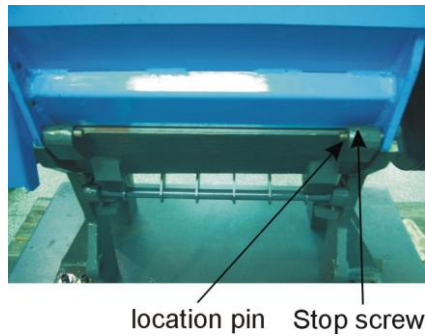

Picture 3-18: Installation of Feed Box and Feed Inletv 2

4) Lockup the two pothooks in front of feed box.

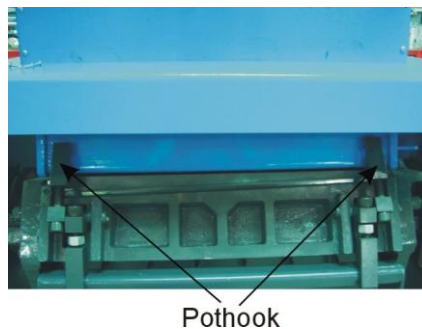

Picture 3-19: Installation of Feed Box and Feed Inletv 3

- 5) Load the pneumatic spring fixing block to the lower left side of the feed box.
- 6) Load the pneumatic spring and make its lower end link to the fixing pole of the electric machine.



Picture 3-20: Installation of Feed Box and Feed Inletv 4

7) Prop up the feed box and install the match scaffold of the hopper base.

- 8) Install stainless fixing blocks on both sides of the feed box.
- 9) Align the positions of the holes of the feed inlet and stainless fixing blocks.
Tighten with screws.

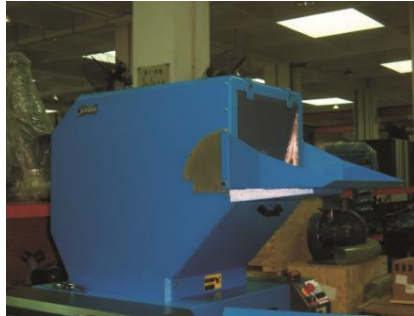

Picture 3-21: Installation of Feed Box and Feed Inletv 5

4. Operation Guide



Wear earplugs during operating to avoid personal injury!



Wear gloves during operating to avoid personal injury!



Wear goggles during operating to avoid personal injury!



Because the blades and rotor may be loosen, check the following items

before operating :

- 1) If the blades has any damage;
- 2) If the surface of the rotor is loosen;
- 3) Push or pull the rotor and blades to see if there is any loose connection.

If any of the above situations is found, please contact local representative or SHINI Company for help.

4.1 Startup Pretest

Unpainted part of the machine has been covered with stainless oil. Before use, the stainless oil should be cleaned.

- 1) Clean with a towel
- 2) Wash with a towel dipping with amyl acetate.

4.1.1 Before the First Startup

- 1) Check whether the granulator is in the level state.



Note!

Adjust the machine to make its four holders to share the weight and be in a level state.

- 2) Check the space of the cutting tools (0.2~0.3mm) to see whether the lockup screws of the blades are tightened (fixed blade M16x50, rotating M16x55).

4.1.2 After first startup for 2 hours

- 1) Check the space of the cutting tools of the fixed blades and rotating blades again; check whether the lockup screws of the blades are loose.
- 2) Check the position-adjusting screws of the motor and check whether the position-adjusting screws are tightened.



Picture 4-1: Position-adjusting screws

4.1.3 After first startup for 20~30 hours

Check and adjust the belt's tensility after a 20~30-hour full-load operation.

4.2 Circuit Connection

The installation of the granulator's circuit must be conducted by the professional electricians.

Connect granulator to the power.

4.2.1 Check the running direction of the motor

- 1) Open the door to check whether the feed box is closed.
- 2) Close the door.
- 3) Ensure the main power switch is in ON position.
- 4) Check the emergency stop.
- 5) Startup.
- 6) The machine can not start there will be an alarm
 - a) Turn off the machine.
 - b) Turn off the interlock breaker.
 - c) Power line phase reverse, exchange each two of the three power lines.

d) Restart from step 5.



CAUTION!

The cutting tools may be damaged and the granulating capability will be reduced if there is a wrong running direction. Please disconnect the power and transpose any two wires of the three in the main power.

4.2.2 Check the running direction of the blower

- 1) Check whether the running direction of the blower is in accordance with the symbol on the shield.
- 2) Connect to the power and stop again to check the blower's running direction.

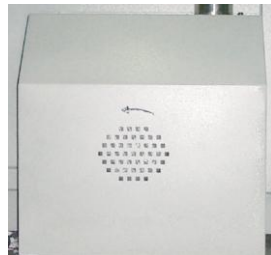

Picture 4-2: Blower



CAUTION!

If the blower's running direction is not in accordance with the symbol, the machine's working capability will be reduced by at least 25 percent. Under these circumstances, please disconnect to the main power and transpose any two wires of the three in the blower.

4.3 Open the Feeding Hopper, Screen and the Storage box



Before opening the feeding hopper, screen and the storage box, turn off the main power switch and the power switch of the granulator.



Be careful! The blade is very sharp, please take care.

4.3.1 Open the feeding hopper

- 1) Check if the feeding hopper and pulverizing room have been emptied. After that, turn off the main power supply.
- 2) Loosen the long star screw and open the door.
- 3) Loosen the lock clip of the hopper and open the cover board of the feed box.
- 4) Open the hopper backward.



CAUTION!

The feeding hopper is held by pneumatic stick to avoid its dropping when opening it.

4.3.2 Open the storage box and screen

- 1) Turn off the power switch of the granulator.
- 2) Loosen the star screw and open the door.
- 3) Loosen the quick coupling hoop in the end of the outfall pipe and transfer it to one side.
- 4) Loosen the star knob and take out the storage box.
- 5) Screw off the hexagon socket cap screws in the pothook to loosen the pothook.
- 6) Take out the screen bracket and withdraw the screen.

4.4 Close the screen bracket; the storage box and the feeding hopper



CAUTION!

Before opening, clean the interface. Take care! DO NOT be squeezed!



Picture 4-3: Close the screen bracket; the storage box and the feeding hopper.

4.4.1 Installation of the screen bracket and the storage box

- 1) Hold to the arc section of the screen bracket and put it in the cutting chamber.

Insert the screen bracket to the hinge pin hole seat and then fasten the screw on the press plate.

- 2) Fold down the screen bracket and then install screen.
- 3) Lift up the front end of the screen bracket and push it toward cutting chamber.
- 4) Install the lockup clip close with the screen bracket to fix the bracket.
- 5) Lift up the storage box and insert it into the cutting chamber's groove. Move the back end carefully downwardly.
- 6) Tighten the star handle on both ends of the storage box.

4.4.2 Close the feed box



CAUTION!

The door must be open; otherwise the feeding hopper cannot be closed.

- 1) Check to ensure there is no powder left in the interface or corners.
- 2) Close the feed box forwardly.
- 3) Lock up the pothook and fix the feed box.

4.5 Turn Off and Stop the Granulator

The granulator is controlled by main power switch, safety switch, START / STOP button and emergency stop.

Main power switch:

Main power switch of granulator is located at the front control panel.

START button and STOP button:

These two buttons control the startup and stop of the machine.

Emergency stop:

When an accident happens, this button can do a favor.



Picture 4-4: Circuit switch

**CAUTION!**

If there are ungrinded crew materials in the feed box or cutting chamber, the granulator shall NOT be stopped, otherwise the crew materials will blockade the rotator and the motor will be overloaded next time you start the machine up.

4.6 Blades Installation Adjusting

All the cutters, including rotating blades and fixed knives, can be adjusted within clamp outside the machine.

Put all the cutters including rotating knives and fixed knives into clamp, adjusting its adjusting screw until the screw reach the clamp.

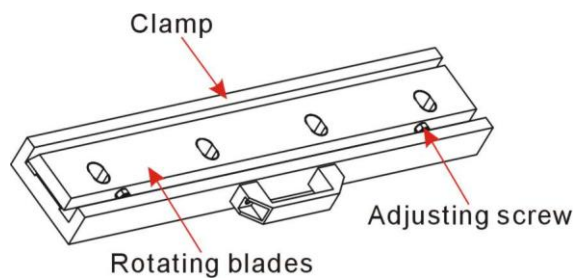

Picture 4-5: Blades Installation Adjusting

5. Trouble Shooting

5.1 Granulator Can Not Work

- 1) Check if the emergency stop has not been reset. If not, rotate the Button anti-clockwise to reset it.
- 2) Check whether the door is closed. If not, the machine could not be started.
- 3) Check if the feed box is completely closed. If not, the machine could not be started. Then, check the lockup clip after opening the door.
- 4) Check the motor's overload protector. The overload protector in the electrical control box will work if the motor overloads. Under that situation, (A) (the green pole) will sprout. Press the Reset button (B) to reset it. Before startup again, check whether there is any powder in the granulator.
- 5) Check the overload protector of the feeding blower's motor. If the feeding blower does not run, the granulator cannot run either. Check the motor protector in the electric control box. If it is closed, the switch will be in 0 positions. Reset it to 1 position. (A) (The green pole) will sprout. Press the Reset button (B) to reset it.
- 6) Check the space between blades A stop will happen or the motor overload protector will work if the blade is very blunt or the space between blades is not correct. More details about checking, replacing and readjusting the blades to see chapter 3.3.
- 7) Upon starting up, warning sounds and machine unable to run indicate power reverse or default phase, please check power connection.



5.2 Stop Due to Other Reasons

Connection failure or looseness of safety switch or limit switch can also result in operation failure.



Note!

Do not disconnect to safety switch or control switch.

6. Maintenance and Repair

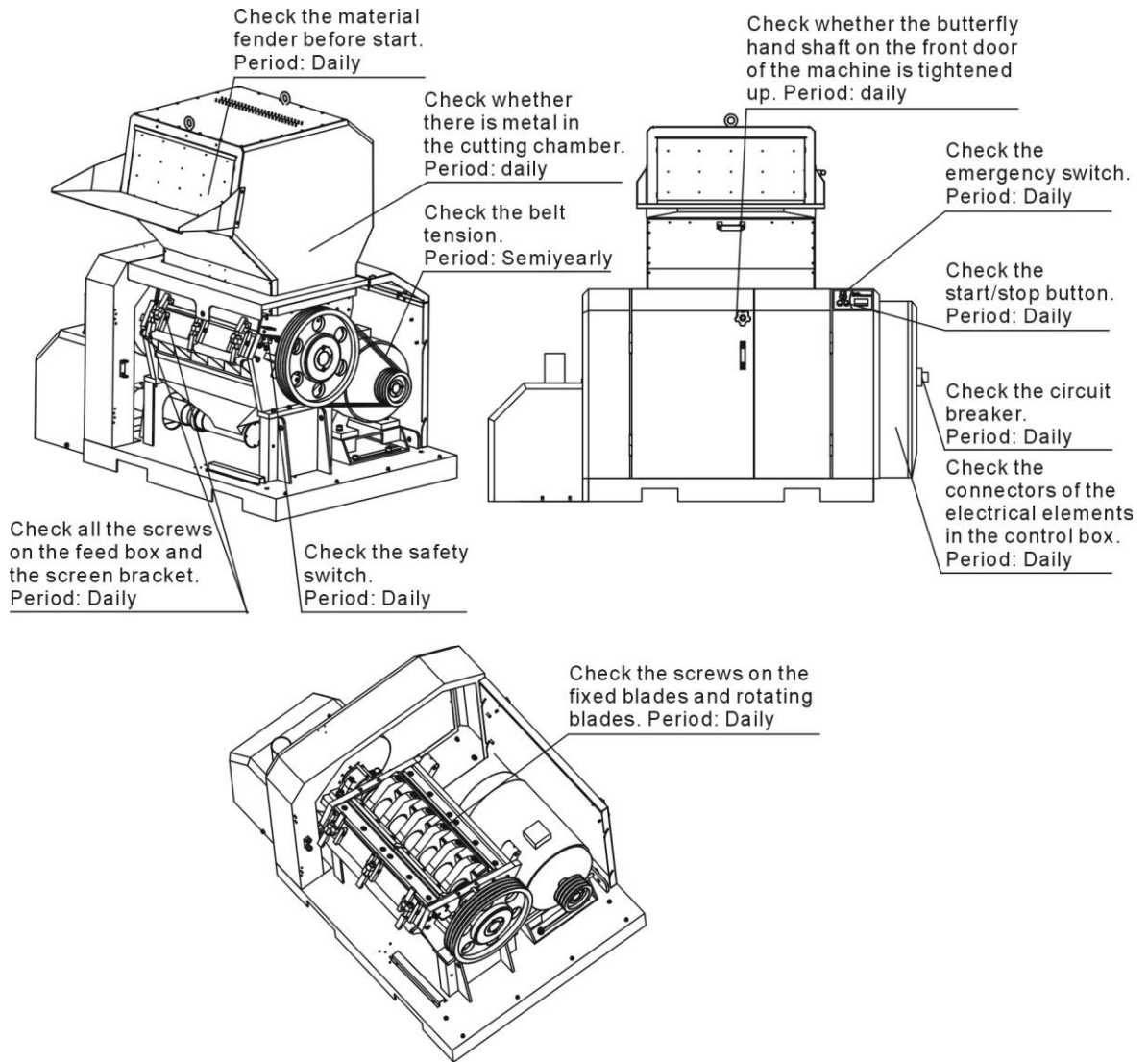

6.1 Repair

The entire repair must be done by professionals to avoid damage to machine and harm to human body.

6.1.1 Replace the Blades



CAUTION!

Warning: Self-rotation exists due to non-balanced forces or unstable barycenter.



Wear gloves to avoid being cut and be careful of the sharp blades!



More details about replacing or maintaining the blades to see chapter 3.5. Inject screw thread fixing glue (blue LOCTITE 243 recommended) tighten all fixing screws to fix the screws.



CAUTION!

To decrease the possibility of harm to other people, the replacement action must be conducted by oneself.

To avoid self-rotation, block the rotating blade with a thick wood block. After replacement, check whether the screen is damaged. If so, replace the screen. Each time to replace the blade, the screw and insulation ring must be replaced also. Before replacing the blades, open the door and feed box, remove the storage box, screen and screen bracket.

1) Remove the rotating blades



CAUTION!

To avoid self rotation, block the rotating blade with a thick wood block.

1. Remove the screws and insulation rings.
2. Remove the blades.
3. Clean the installation surface of the blades.

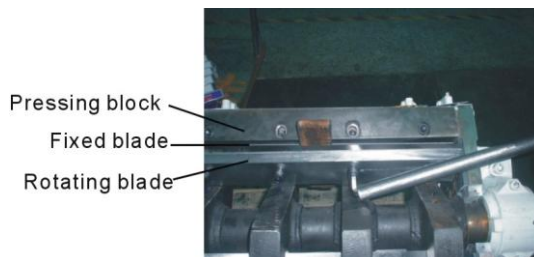

Picture 6-1: Remove the rotating blades

2) Remove the fixed blades

1. Revolve the screw of the front fixed blade.

2. Loosen and remove the hexagon socket cap screw.
3. Remove pressing block and blade, clean the blade rest.
4. Loosen and remove the screws of the back blades.
5. Loosen and remove the hexagon socket cap screw again, remove the pressing block and blade. Clean the supporter box.

3) Install the blades

Clean carefully the fixed blades and rotating blades and then install them.



CAUTION!

Each time to replace the blade, the screw and insulation ring must be replaced also. More details about replacing or maintaining the blades to see chapter 3.5.

6.2 Transferring



Maintenance or repair the transmission belts after pressing down the emergency stop button or main power switch!

6.2.1 Daily maintenance of V belts

There are four V belts according to motor power.

1) Check the V belts

Check V belts' tensility after a full-load operation for 20-30 hours. And then check its abrasion condition.

2) Check V belts' tensility every 6 months.

Remove the upper panel in the back end of the granulator. Rotate the V belts for several circles to see if there is any damage.



CAUTION!

Pinch rist! Do not place your hands between wheels and the belts.

If it is necessary, check the belt's tensility via enforce extra force (75N) and measure its excursion. This extra force is determined by power and frequency of the motor. More Details to see the following table.

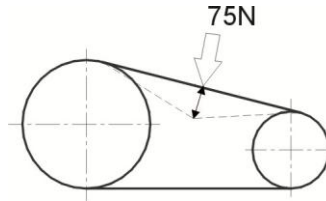

Picture 6-2: Daily maintenance of V belts

Motor 50Hz	18.5/22kW	30/37kW	45-55kW
New belt	15mm	14mm	15mm
Old belt (Six- month later))	19mm	19mm	19mm
Motor 60Hz	18.5/22kW	30/37kW	45-55kW
New belt	18mm	17mm	16mm
Old belt (Six- month later)	23mm	23mm	20mm

6.2.2 Adjustments of V belts

1. Remove the upper panel and feeding plate in the back end of the granulator and open the box door.
2. Open the quick coupling clip in the end of the outlet pipe and remove the storage box.
3. Adjust the belt's tensility via changing the space between the driving wheels and the driven wheels with two moving screws.
4. Lock up the two moving screws. Recheck the belts' tensility after a full-load operation for 20-30 hours.



Picture 6-3: Adjustments of V belts

6.3 Lubrication

6.3.1 Lubricating oils

Xin Chang Long: FX-00
FX-000

Bp: BP Grease LGEP 2

ESSO: Beacon Ep2, Beacon EP2

Mobil: Mobilux EP2

Shell: Shell Alvania EP2

Texaco: Multifak Ep2, Novotex Grease EP2

6.3.2 Please grease the bearing with lubricating oils periodically

Inject lubricating oil via throat with an oil greaser. If the granulator is not used for a long time, please grease anti-rust oil in blade rest, fixed blade, rotating blade, cutting chamber and screws to avoid dust.



Oil throat

Picture 6-4: Oil throat

6.4 Cleaning



CAUTION: The blade may do harm to human body when opening the feeding hopper!

- 1) Check whether the feed box is emptied before stopping the machine.
- 2) Clean the exterior surface of the feed box.
- 3) Turn off the main power switch.

- 4) Clean the shutter of the feed box with a dust separator.
- 5) Open the door of the granulator.
- 6) Loosen the lockup clip and then open the feed box backWardly.



Note!

The feed box is held by pneumatic spring, therefore it cannot fall down.

- 7) Clean the interior surface of the feed box.
- 8) Remove the quick coupling clip from one end of the pipe, loosen the star knob on the storage box.
- 9) Uninstall the storage box.



Note!

Lift the storage box in both hands so it would not fall down. Fold down the front end of the storage box and draw it forwardly; lift it and push it backWardly at the same time; remove it forwardly and upwardly.

- 10) Loosen the lock wiring in the screen bracket and remove the screen bracket.



Note!

Lift the screen with hands so it would not fall down.

- 11) Take out the screen.
- 12) Hold to the screen and take it out outwardly.
- 13) Clean the storage box, screen bracket and the screen.
- 14) Clean both surfaces of the cutting chamber.
- 15) Clean every transmission pipe, blower, and cyclone dust separator;
- 16) Clean the wheels with bright dust-precipitator.

Reinstall after cleaning



CAUTION!

Take care not to be squeezed when closing the door!

- 1) Install the screen bracket.
- 2) Put the screen bracket in the cutting cahmber and insert the screen bracket to the hinge pin hole seat and then fasten the screw on the press plate.

- 3) Fold down the screen bracket and install the screen
- 4) Hold to handle and push the front end of the screen bracket in the direction of cutting chamber. Fix the screen bracket via connect the pothook to the screen bracket.
- 5) Install the storage box. Lift it up to make its tail into the groove of the cutting chamber. Move slowly the back end of the storage box and let it slide until stop; fasten the star knob on the storage box.
- 6) Install the quick coupling clip at the end of the outlet pipe.
- 7) Close the feed box.



Note!

Before closing the feed box the door must be open; check if there is any residual powder left in the interface and edges; close and fix the feed box with pothook.

- 8) Install the rubber shutter of the feed box.
- 9) Tighten the lockup buckle and close the door.
- 10) Check if the feed box is emptied.
- 11) Open the main power switch.
- 12) Start the machine.

6.5 Maintenance Schedule

6.5.1 About the Machine

Model _____ SN _____ Manufacture date _____

Voltage _____ Φ _____ V Frequency _____ Hz Power _____ kW

6.5.2 Check after Installation

- Check if pipe connections are firmly locked by clips.
- Check the gap between fixed blade and rotating blade. (0.2~0.3mm).
- Check the rotating balance of the belt wheel.

Electrical Installation

- Voltage: _____ V _____ Hz
- Specs of the fuse: 1 Phase _____ A 3 Phase _____ A
- Check phase sequence of the power supply.
- Check the rotating direction of the conveying blower.

6.5.3 Daily Check

- Check main power switch.
- Check emergency stop button.
- Check start / stop button.
- Check material check plate (strip) is perfect or not.
- Check whether emergency stop and safety switch works normally.
- Clean screen and feeding hooper.
- Check whether start, stop and power switches are normal.

6.5.4 Weekly Check

- Check all the electrical cables.
- Check if there are loose connections of electrical components.
- Check blade condition.
- Check whether set screws in fixed and rotate blades are under looseness.
- Check if there is abnormal noise, vibration and heat in reduction gear.
- Check the cracking window

6.5.5 Monthly Check

- Check the status of the belt.
- Check the overload protection function of the motor.
- Check motor reversed running function.
- Check the tightness of the blades.
- Check whether clamp ring of pulley is fastened.
- Check belt tension.

6.5.6 Check Half-yearly or Every 1000 Running Hours

- Check or replace lubrication for gear motor.

- Check lubrication of bearing.
- Check **coupling**.
- Evaluation of the machine condition.**

6.5.7 3 year Checking

- PC board renewal.
- No **fuse** breaker renewal.