

SHD-U Series

Hopper Dryer

Date: May. 2018

Version: Ver.D (English)



Contents

1. General Description	7
1.1 Coding Principle	8
1.2 Feature	8
1.3 Technical Specifications.....	10
1.3.1 Outline Drawing	10
1.3.2 Specifications	10
1.4 Safety Regulations	12
Note!	12
1.4.1 Safety Signs and Labels.....	12
1.4.2 Signs and Labels	13
1.5 Exemption Clause	13
2. Structure Characteristics and Working Principle	14
2.1 Working Principle	14
2.1.1 Working Principle Illustration	14
2.2 Optional Accessories	15
2.2.1 Heatless Dehumidifying Hot-air Dryer	15
2.2.2 Safety Ladder	15
2.2.3 Hopper Magnet.....	16
2.2.4 Floor Stand	16
2.2.5 Magnetic Base.....	17
2.2.6 HAR-U "Euro" Hot Air Recycler	17
2.2.7 AIF-U "Euro" Blower Inlet Filter	23
2.2.8 ADC-U "Euro" Air Filter.....	29
3. Installation Testing.....	34
3.1 Machine Location	34
3.1.1 Install Directly on a Moulding Machine	34
3.1.2 To be used with Hopper Loaders.....	34
3.2 Power Connectors.....	35
4. Application and Operation.....	36

4.1	Control Panel	36
4.1.1	Panel Operation.....	36
4.1.2	Temperature Setting.....	36
4.1.3	Temperature Lock	36
4.1.4	PID Setting	37
4.1.5	Intermittent Operation Setting.....	38
4.1.6	One-week Timing Setting	38
4.1.7	Communication Setting (optional functions)	38
4.1.8	Operation Flow	40
4.1.9	Wrong Codes Remark	41
5.	Trouble-shooting	42
6.	Maintenance and Repair	43
6.1	Blower	46
6.2	Maintenance Schedule.....	46
6.2.1	General Machine Information	46
6.2.2	Installation & Inspection.....	46
6.2.3	Daily Checking.....	46
6.2.4	Weekly Checking.....	46
6.2.5	Monthly Checking	46
6.2.6	Half-yearly Checking	47

Table Index

Table 1-1:	Specifications	10
Table 2-5:	ADC-U Specifications	29

Picture Index

Picture 1-1:	Outline Drawing	10
Picture 2-1:	Working Principle Illustration	14
Picture 2-2:	SHD-U-HD Working Principle.....	15
Picture 2-3:	Safety Ladder	15

Picture 2-4: Hopper Magnet.....	16
Picture 2-5: Floor Stand.....	16
Picture 2-6: Magnetic Base.....	17
Picture 2-7: "Euro" Hot Air Recycler	17
Picture 2-8: Technical Specifications	19
Picture 2-9: Working Principle	20
Picture 2-10: Installation of Filter and Dust Collecting Barrel.....	20
Picture 2-11: Installation of the Assembly Parts for the Cylinder Filter	21
Picture 2-12: Install "Euro" Hot Air Recycler on Hopper Dryer.....	21
Picture 2-13: Installation of the Flange of Blower Inlet.....	22
Picture 2-14: Connection of Air Pipe.....	22
Picture 2-15: Clean up the "Euro" Hot Air Recycler	23
Picture 2-16: "Euro" Blower Inlet Filter.....	23
Picture 2-17: Technical Specifications	24
Picture 2-18: Working Principle	25
Picture 2-19: Installation of Filter and Dust Collecting Barrel.....	26
Picture 2-20: Installation of the Assembly Parts for the Cylinder Filter	26
Picture 2-21: Install "Euro" Hot Air Recycler on Hopper Dryer.....	27
Picture 2-22: Installation of the Flange of Blower Inlet.....	27
Picture 2-23: Connection of Air Pipe.....	28
Picture 2-24: Clean up the "Euro" Hot Air Recycler	28
Picture 2-25: "Euro" Air Filter	29
Picture 2-26: ADC-U Technical Specifications.....	30
Picture 2-27: Installation of Filter and Dust Collecting Barrel.....	31
Picture 2-28: Installation of the Assembly Parts for the Cylinder Filter	32
Picture 2-29: Install "Euro" Hot Air Recycler on Hopper Dryer.....	32
Picture 2-30: Installation of the Flange of Blower Inlet.....	33
Picture 2-31: Connection of Air Pipe.....	33
Picture 2-32: Clean up the "Euro" Hot Air Recycler	33
Picture 3-1: Install Directly on a Moulding Machine	34
Picture 3-2: To be used with Hopper Loaders	34

1. General Description



Read this manual carefully before operation to prevent damage of the machine or personal injuries.

SHD-U series hopper dryer adopt hot air down-blowing design and use stainless steel made material hoppers to avoid contamination. With this design, they are also ideally suitable for use with honeycomb dehumidifiers to dry engineering plastics. There are 25 models available, ranging from 20 to 8,000 liters.



Model: SHD-300U

1.1 Coding Principle

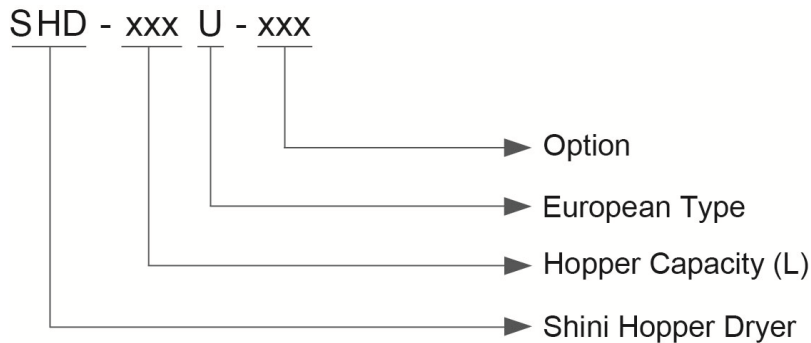

1.2 Feature

- Adopt P.I.D temperature control and LCD display, with RS485 communication function.
- Overheat protection to ensure reliable operation.
- 7-day automatic start/stop timer to improve energy saving.
- Unique design of downblow air pipe can spread hot air evenly, keeping plastics dry and temperature stable to raise drying efficiency.
- Models SHD-80U and above have material clearance door to make the clean more convenient and effective.
- SHD-450U and models below are equipped with stainless steel lining aluminium base. SHD-600U-750U are equipped with aluminium magnetic base. SHD-900U and model above are equipped with manual butterfly valve.
- For SHD-900U models and above, floor stand is standard equipment.

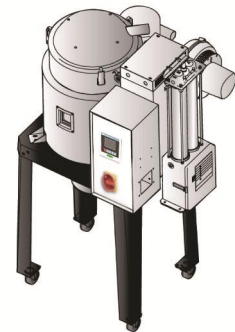

SHD-80U-HD
& Floor Stand (optional)

All service work should be carried out by a person with technical training or corresponding professional experience. The manual contains instructions for both handling and servicing. Chapter 6, which contains service instructions intended for service engineers. Other chapters contain instructions for the daily operator.

Any modifications of the machine must be approved by SHINI in order to avoid personal injury and damage to machine. We shall not be liable for any damage caused by unauthorized change of the machine.

Our company provides excellent after-sales service. Should you have any problem during using the machine, please contact the company or the local vendor.

Headquarter and Taipei factory:

Tel: (886) 2 2680 9119

Shini Plastics Technologies (Dongguan), Inc:

Tel: (86) 769 8111 6600

Shini Plastics Technologies India Pvt.Ltd.:

Tel: (91) 250 3021 166

1.3 Technical Specifications

1.3.1 Outline Drawing

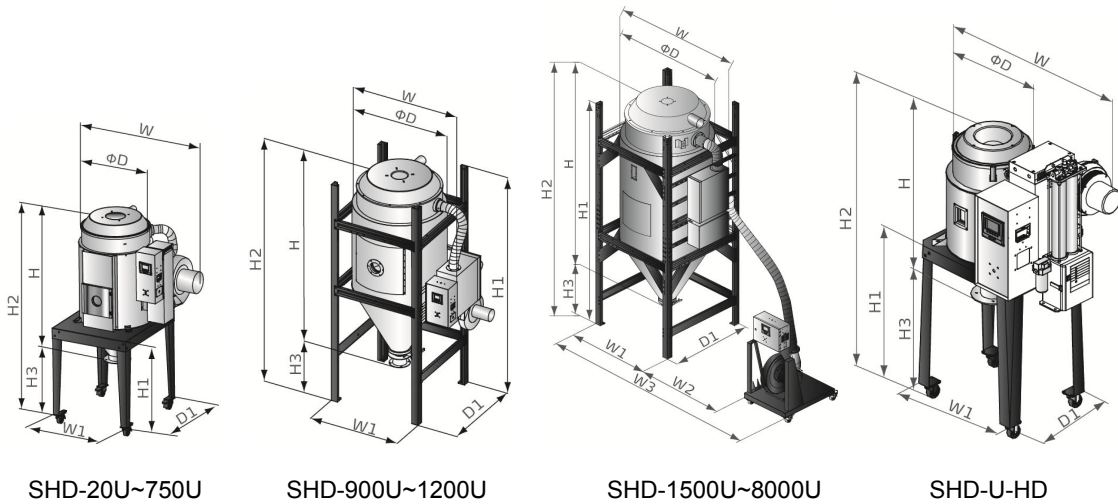

Picture 1-1: Outline Drawing

1.3.2 Specifications

Table 1-1: Specifications

Model SHD-	Ver.	Loading Capacity (L)	Heater Power (Kw)	Blower (Kw)	Dimensions (mm)H×W×D	Floor Stand (mm) H1×W1×D1	W2 (mm)	W3 (mm)	Whole Height (mm)H2	Height of discharge port (mm)H3	Air Inlet PipeDia. (inch)	Air Outlet PipeDia. (inch)	Weight (kg)
20U	B	20	2.2	0.05	680×575×325	790×450×550	-	-	1260	570	2	1.5	40
40U (-HD)	C	40	3	0.12	770×770×394	790×580×450	-	-	1300	540	2	1.5	70
80U (-HD)	C	80	3.9	0.12	940×860×472	840×730×560	-	-	1480	550	2.5	2	85
120U (-HD)	C	120	3.9	0.12	1190×860×472	840×730×560	-	-	1740	550	2.5	2	100
160U	B	160	6	0.12	1200×875×575	920×652×795	-	-	1825	570	3	2.5	90
230U (-HD)	B	230	6	0.12	1470×875×575	920×652×795	-	-	2105	570	3	2.5	115
300U	B	300	12	0.18	1430×1005×695	970×790×930	-	-	2085	550	3	2.5	130
450U	B	450	12	0.18	1840×1005×695	970×790×930	-	-	2435	550	3	2.5	160
600U	B	600	18	0.55	1830×1250×915	1130×1000×1200	-	-	2470	605	4	3	200
750U	B	750	18	0.55	2080×1250×915	1130×1000×1200	-	-	2780	605	4	3	220
900U	C	900	18	0.55	2330×1410×1050	2760×1130×1130	-	-	2765	425	4	4	410
1200U	C	1200	24	1.1	2765×1410×1050	3190×1145×1145	-	-	3190	425	4	4	560
1500U	C	1500	32	3	3095×1640×1250	3470×1340×1340	400	2000	3470	360	5	5	685
2000U	C	2000	32	3	3685×1542×1250	3870×1340×1340	400	2000	3870	360	5	5	770
2500U	C	2500	58	5.5	3735×1798×1400	4000×1482×1482	400	2260	4000	295	6	6	800

3000U	C	3000	58	5.5	4135×1798×1400	4400×1482×1482	400	2260	4400	295	6	6	900
3500U	D	3500	64	7.5	4535×1798×1400	4800×1482×1482	400	2260	4800	295	6	6	1010
4000U	D	4000	64	7.5	4180×2010×1600	4550×1680×1680	400	2460	4635	405	8	8	1160
5000U	C	5000	80	11	4775×2010×1600	5150×1680×1680	400	2530	5235	390	8	8	1390
6000U	C	6000	96	15	4520×2250×1800	4870×1930×1930	400	2780	4923	350	8	8	1530
7000U	-	7000	112	18.5	5460×2250×1800	5370×1930×1930	400	2830	6330	380	8	8	1735
8000U	C	8000	128	22	6030×2250×1800	5620×1930×1930	400	2830	6425	390	10	10	1820

Power supply: 3Φ, 230 / 400 / 460 / 575V, 50 / 60Hz.

We reserve the right to change specifications without prior notice.

1.4 Safety Regulations



Note!

Electrical installation should be done by qualified electrician only. Before connecting to AC Power Source, turn power switch to OFF position. While AC power source is connected, make sure specifications and overload protection rating of the power switch are suitable and reliable. When the machine is under care or maintenance, turn off both power switch and automatic operation switch.

1.4.1 Safety Signs and Labels



Danger!

High Voltage!

It is attached to the control box.



Attention!

This mark reminds you to be more careful.



Warning!

High temperature surface may burn hands!

This label should be stick to the shell of electric heating box.



No need for regular inspection because all the electrical parts in the control unit are fixed tightly!



Attention!

To prevent over-temperature alarm from causing machine shutdown, don't randomly adjust EGO setting temp.



Attention!

For test of SHD-2500U and above models, connect all hot air pipes to avoid damage of the blower.



Attention!

For test of SHD-2500U and above models, half-open the air-in valve of the blower to avoid damage of it.

1.4.2 Signs and Labels

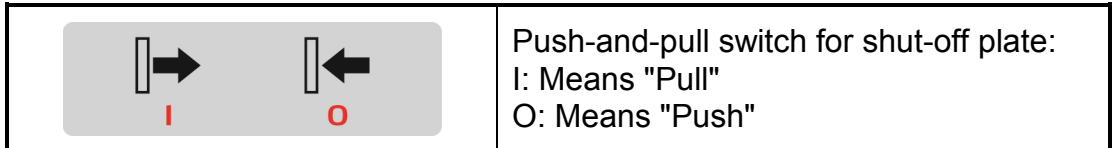

1.5 Exemption Clause

The following statements clarify the responsibilities and regulations born by any buyer or user who purchases products and accessories from Shini (including employees and agents).

Shini is exempted from liability for any costs, fees, claims and losses caused by reasons below:

1. Any careless or man-made installations, operation and maintenances upon machines without referring to the Manual prior to machine using.
2. Any incidents beyond human reasonable controls, which include man-made vicious or deliberate damages or abnormal power, and machine faults caused by irresistible natural disasters including fire, flood, storm and earthquake.
3. Any operational actions that are not authorized by Shini upon machine, including adding or replacing accessories, dismantling, delivering or repairing.
4. Employing consumables or oil media that are not appointed by Shini.

2. Structure Characteristics and Working Principle

2.1 Working Principle

In the drying process, hot air with constant temperature is blown by a blower into a two-layer insulated hopper to dry the materials. Moisture will be separated out and taken away by hot air, thus to gain a satisfied drying effect.

2.1.1 Working Principle Illustration

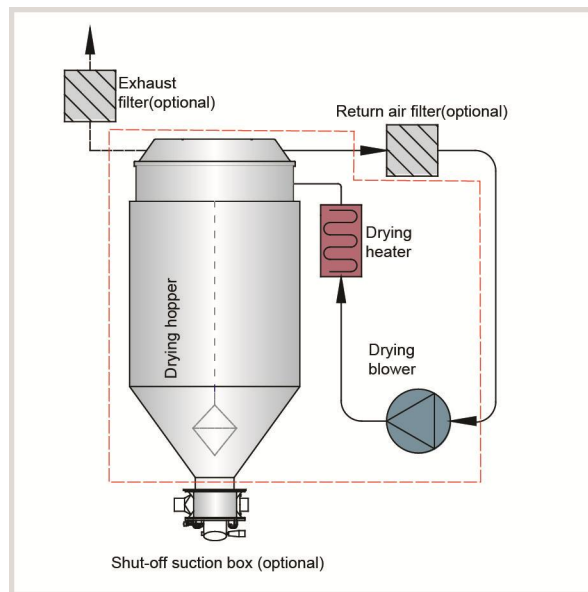

Air blown out of drying blower becomes high temperature drying air after being heated. Through particular down-blowing air pipe, hot air can be equably dispersed in the material storage tank. Hot air recycler can be equipped to filter and recycle the air from the air outlet and form a closed loop circle.

Picture 2-1: Working Principle Illustration

2.2 Optional Accessories

2.2.1 Heatless Dehumidifying Hot-air Dryer

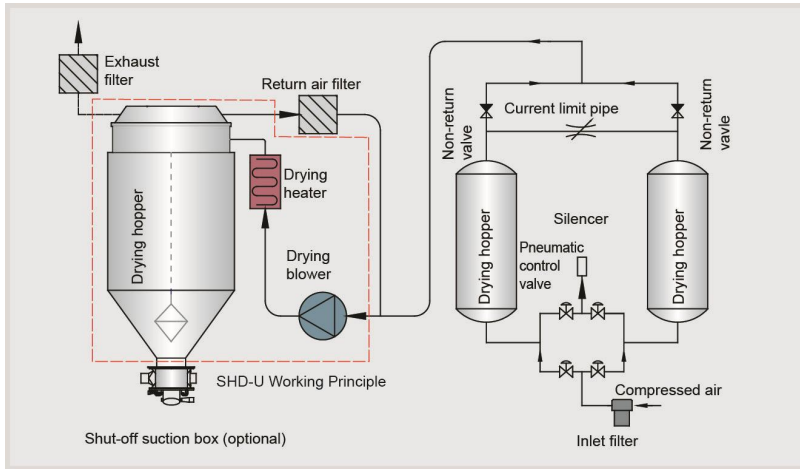

Picture 2-2: SHD-U-HD Working Principle

Optionally equipped with heatless regenerative air dryer, which could offer low dewpoint dry air without regenerative heating and speed up the drying of material, Add "HD" at the end of the mode code.

Model	SHD-40U-HD	SHD-80U-HD	SHD-120U-HD	SHD-230U-HD
Applied to	SHD-40U-HD	SHD-80U-HD	SHD-120U-HD	SHD-230U-HD
HAD	-0106-06	-0106-06	-0206-06	-03506-06

2.2.2 Safety Ladder



Picture 2-3: Safety Ladder

For SHD-1500 and above models are available to option with safety ladder. Add "ML" at the end of the model code.

2.2.3 Hopper Magnet



Picture 2-4: Hopper Magnet

Absorb metal scraps in the material to avoid the damage of molding screw.

Model	Applied to	Aluminum Holder ×2 (mm/inch)
MR-5	SHD-20U	(148 × 80 × 2.3)
MR-7	SHD-40U~120U	(190 × 80 × 2.3)
MR-9	SHD-160U~750U	(240 × 80 × 2.3)
MR-11	SHD-900U 以上	(298 × 80 × 2.3)

2.2.4 Floor Stand

Each model can be supplied with suitable floor stand for easy moving.



Suitable for SHD-20U~750U

Picture 2-5: Floor Stand

Floor stand	Suitable machine model	Specifications (mm)		
		Length (mm)	Width (mm)	Height (mm)
FSU-20	SHD-20U	550	450	790
FSU-40	SHD-40U			
FSU-80	SHD-80U	722	552	840
	SHD-120U			
FSU-160	SHD-160U	795	652	920
	SHD-230U			
FSU-300	SHD-300U	930	790	970
	SHD-450U			
FSU-600	SHD-600U	1200	1000	1130
	SHD-750U			

2.2.5 Magnetic Base



Picture 2-6: Magnetic Base

Made of aluminum with built-in hopper magnet, can effectively separate metal scraps out to avoid material contamination. (MB-400 is standard configuration)

Model	Applied to	Magnetic Frame	Aluminum Holder×2 (mm/inch)
MB-12	SHD-20U	MR-3	(88.5×78×2.3) mm
MB-20U	SHD-20U		
MB-50	SHD-40U~120U		
MB-40U	SHD-40U~120U		
MB-100	SHD-160U~450U		(119×105×2.3)mm
MB-160U	SHD-160U~450U		
MB-600U	SHD-600U~750U		

2.2.6 HAR-U "Euro" Hot Air Recycler

HAR-U "Euro" hot air recycler has energy saving and dust-collecting function, its design is for working with "Euro" dryer to form a sealed loop. This machine has a simple structure and very easy for installation. High efficiency in hot air recycling use will save energy up to 40% and improve the production efficiency greatly. The built-inside filter can maintain the air clean so to ensure production quality. The machine has a backup air adjusting valve and moisture drainage bore to make better recycling use of hot air.



Model: SHD-80U+HAR-80U

Picture 2-7: "Euro" Hot Air Recycler

Features:

1. Hot air recycling can reduce the temperature of the plant.
2. Keep the air in the plant clean so can ensure production quality.
3. Because the hot air heats up faster, so can greatly cut the energy consumption up to 40%.
4. Economical and less space occupation, can work on the original "Euro" hopper dryer.
5. Adjustable backup air device.
6. Beautiful appearance, optimal structure and especially easy for installation.

2.2.6.1 Technical Specification

1) Specifications

Table 2-1: Specifications

Model	Filtering Barrel Dia. (mm)(ΦD3)	Air inlet Pipe Dia. (mm)(ΦD1)	Air Outlet Pipe Dia. (mm)(ΦD2)	Applicable Models / Fixed Plate	Blower Flange (With Air Quantity Adaptor)
HAR-20U	120	1.5	2	SHD-20U	Air Inlet Flange for 0.05kW blower
HAR-40U				SHD-40U	
HAR-80U	225	2	3	SHD-80U~120U	Air Inlet Flange for 0.12kW blower
HAR-160U	225	2.5	3	SHD-160U~230U	
HAR-300U	225	2.5	4	SHD-300U~450U	Air Inlet Flange for 0.18kW blower
HAR-600U	225	3		SHD-600U~750U	Air Inlet Flange for 0.55kW blower
HAR-900U	225	4		SHD-900U	
HAR-1200U	225	4	4	SHD-1200U	Air Inlet Flange for 1.1kW blower
HAR-1500U	280	5	5	SHD-1500U~2000U	Air Inlet Flange for 3kW blower
HAR-2500U	340	6	6	SHD-2500U~3000U	Air Inlet Flange for 5.5kW blower
				SHD-3500U	Air Inlet Flange for 7.5kW blower
HAR-4000U	340	8	8	SHD-4000U	Air Inlet Flange for 7.5kW blower
				SHD-5000U	Air Inlet Flange for 11kW blower
HAR-5500U	420	8	8	SHD-6000U	Air Inlet Flange for 15kW blower
				SHD-7000U	Air Inlet Flange for 18.5kW blower
HAR-8000U	420	10	10	SHD-8000U	Air Inlet Flange for 22kW blower

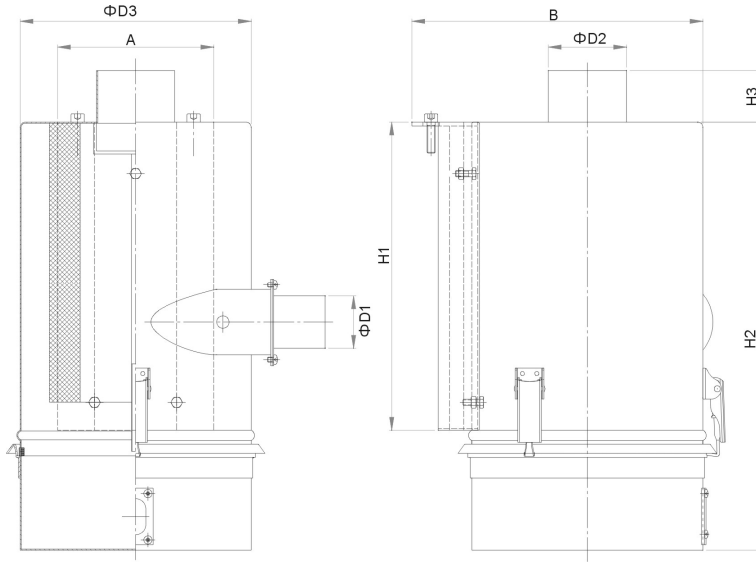

Picture 2-8: Technical Specifications

2) Technical Specifications

Table 2-2: Out Dimensions

Model	A(mm)	B(mm)	D1(mm)	D2(mm)	D3(mm)	H1(mm)	H2(mm)	H3(mm)
HAR-20U	92	253	38	50.8	128	170	362	50
HAR-40U		217						
HAR-80U	152	314	51	76.2	225	303	405	50
HAR-120U								
HAR-160	152	314	63.5	76.2	225	303	405	50
HAR-230U								
HAR-300U	152	310	63.5	101.6	225	345	450	50
HAR-450U								
HAR-600U	152	322	76.2	101.6	225	345	450	50
HAR-750U								
HAR-900U	152	322	101.6	101.6	225	345	450	50
HAR-1200U								
HAR-2500U	200	490	152.4	152.4	340	605	818	240

2.2.6.2 Working Principle

HAR-U "Euro" hot air recycler has filter built in to connect the air vent of the dryer and backup air inlet of the blower. The hot air that discharged from dryer's air vent has moisture and dust powder, within which the humid air is discharged from the bores on filter barrel. After filtering by the filter, the residual hot air will be heated by the electric heater, and will enter the dry drum again to dry the materials, so it

can be used repeatedly.

HAR-U hot air recycler has rotary air adjusting aluminum sleeve (A), customer can unscrew the lockup screw (B) according to practical requirement to adjust the coming air in the dryer.

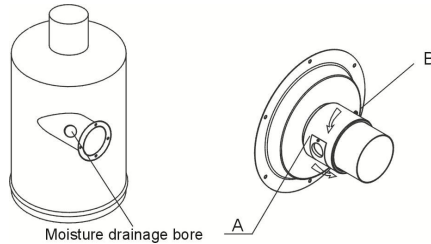

Picture 2-9: Working Principle



Caution!

If there happens to be no moisture drainage bore on the air inlet pipe of filter barrel, please drill one or contact our company directly.

2.2.6.3 Installation Steps

1. Installation of Filter and Dust Collecting Barrel

- 1) Mount the three spring clips of the assembly parts (4) on a proper place of filter barrel at first.
- 2) Mount filter (5) inside the filter barrel (1) and lock it with lockup washer (6), flat washer (7) and butterfly nut (8).
- 3) Install dust collecting barrel and lock it up with spring clip.
- 4) Mount the flange (2) for air inlet pipe and lock it with screw (3).

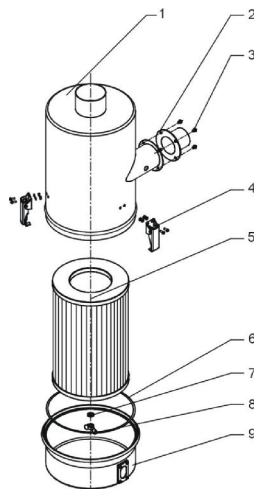

Picture 2-10: Installation of Filter and Dust Collecting Barrel

2. Installation of the Assembly Parts for the Cylinder Filter

- 1) First install filter barrel components (3) The bolt is installed in the installation board of filtering bucket.
- 2) Tighten up the fixing screw (1).

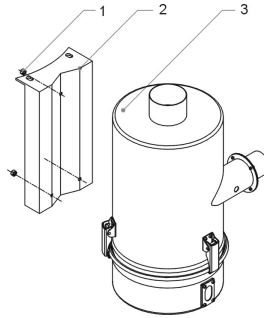

Picture 2-11: Installation of the Assembly Parts for the Cylinder Filter

3. Install "Euro" Hot Air Recycler on Hopper Dryer

- 1) Put hot air recycler (3) on a proper place of hopper dryer (1), and confirm the location of installation bores on the aluminum ring of the hopper dryer (1).
- 2) Drill out respective installation bores.
- 3) Mount on the hot air recycler (3), lock up the fixing screw (2).

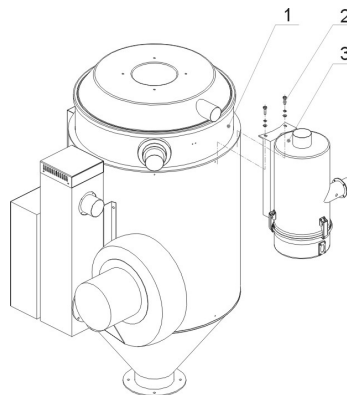

Picture 2-12: Install "Euro" Hot Air Recycler on Hopper Dryer

4. Installation of the Flange of Blower Inlet

- 1) First insert the aluminum made air volume adjusting ring assembly parts (4) onto the coupling flange (2), to align the air adjusting bore, then screw the insertive screw (5).
- 2) Mount coupling flange at the blower's air inlet (5), tighten up the screw (3).



Warning!

If blower has standard flange, please disassembly it.

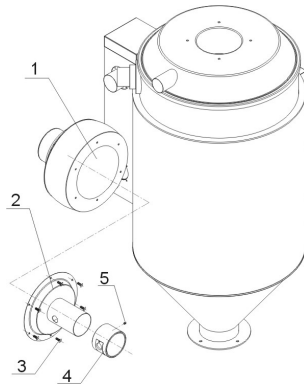

Picture 2-13: Installation of the Flange of Blower Inlet

5. Connection of Air Pipe

1) Mount on air pipe in suitable size according.

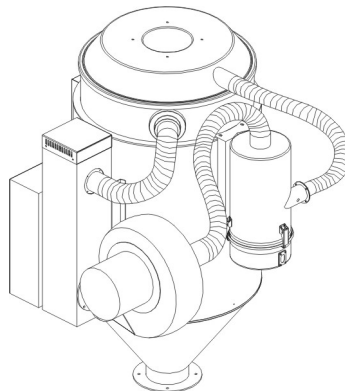

Picture 2-14: Connection of Air Pipe

2.2.6.4 Clean up the "Euro" Hot Air Recycler

- 1) Loosen the spring clip (1), and take out the dust collecting barrel (4) of the hot air recycler.
- 2) Unscrew the butterfly nut (3), and take out the filter (2) then clean it with a high pressure air jetter.
- 3) Install the filter in opposite steps.

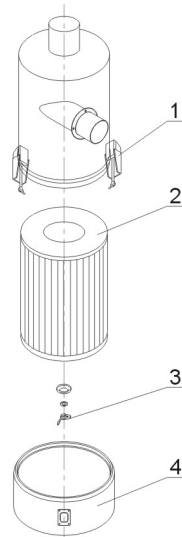

Picture 2-15: Clean up the "Euro" Hot Air Recycler

2.2.7 AIF-U "Euro" Blower Inlet Filter

AIF-U "Euro" blower inlet filter has filtering and dust-collecting function. Its design is for working with "Euro" dryer and can be installed at the backup air inlet of the blower. This machine features simple structure, easier installation and greatly improves the production efficiency. The built-inside filter can maintain the air clean so to ensure production quality. The machine has also configured with a backup air adjusting valve.



Model: AIF-80U

Picture 2-16: "Euro" Blower Inlet Filter

Features:

1. Filter the air at the blower inlet to improve the production quality.
2. Economical and less space occupation, can work on the original "Euro" hopper dryer.
3. Beautiful appearance, optimal structure and especially easy for installation.

2.2.7.1 Technical Specification

1) Specifications

Table 2-3: Specifications

Model	Filtering Barrel Dia. (Mm)	Air inlet Pipe Dia. (inch)	Air Outlet Pipe Dia. (inch)	Applicable Models	Fixed Plate	Blower Flange (With Air Quantity Adaptor)
AIF-20U	120	1.	2	SHD-20U	SHD-20U	Air Inlet Flange for 0.05kW blower
AIF-40U				SHD-40U	SHD-40U	Air Inlet Flange for 0.12kW blower
AIF-80U	225	2	3	SHD-80U~120U	SHD-80U~120U	
AIF-160U	225	2.5	3	SHD-160U~230U	SHD-160U~230U	
AIF-300U	225	2.5	4	SHD-300U~450U	SHD-300U~450U	Air Inlet Flange for 0.18kW blower
AIF-600U	225	3		SHD-600U~750U	SHD-600U~750U	Air Inlet Flange for 0.55kW blower
AIF-900U	225	4		SHD-900U	SHD-900U	
AIF-1200U	225	4	4	SHD-1200U	SHD-1200U	Air Inlet Flange for 1.1kW blower
AIF-2500U	340	6	6	SHD-2500U	SHD-2500U	Air Inlet Flange for 5.5 kW blower
				SHD-3500U	SHD-3500U	Air Inlet Flange for 7.5kW blower

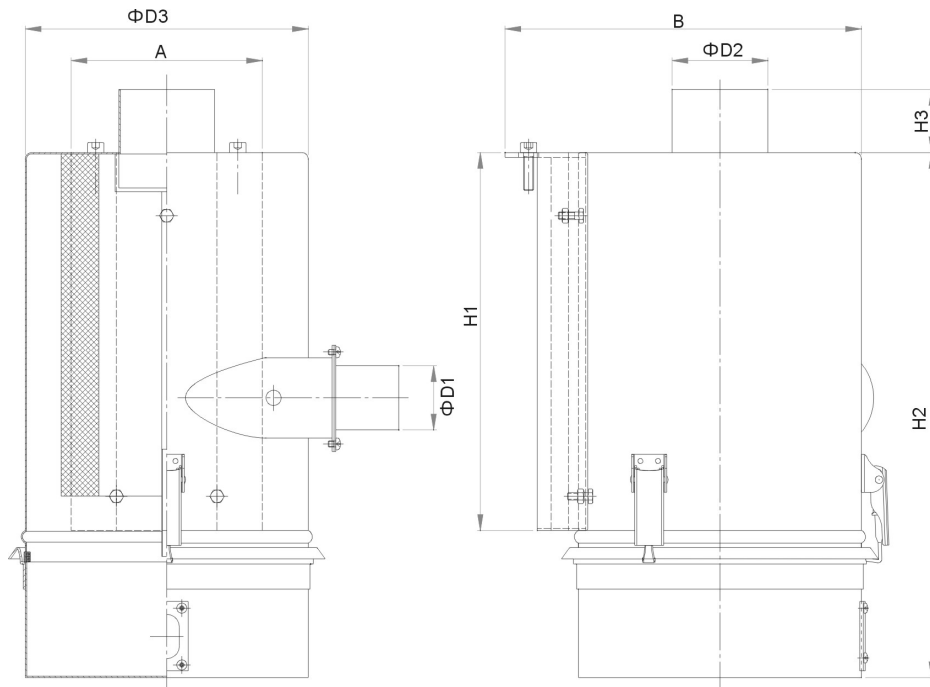

Picture 2-17: Technical Specifications

2) Technical Specifications

Table 2-4: Out Dimensions

Model	A(mm)	B(mm)	D1(mm)	D2(mm)	D3(mm)	H1(mm)	H2(mm)	H3(mm)
AIF -20U	92	253	38	50.8	128	170	362	50
AIF -40U		217						
AIF -80U	152	314	51	76.2	225	303	405	50
AIF -120U								
AIF -160	152	314	63.5	76.2	225	303	405	50
AIF -230U								
AIF -300U	152	310	63.5	101.6	225	345	450	50
AIF -450U								
AIF -600U	152	322	76.2	101.6	225	345	450	50
AIF 750U								
AIF -900U	152	322	101.6	101.6	225	345	450	50
AIF -1200U								
AIF - 2500U	200	490	152.4	152.4	340	605	818	240

2.2.7.2 Working Principle

AIF-U "Euro" blower inlet filter has filter built in to connect the air vent of backup air inlet of the dryer blower and air vent of filter blower to improve production quality.

AIF-U "Euro" blower inlet filter has rotary air adjusting aluminum sleeve (A), customer can unscrew the lockup screw (B) according to practical requirement to adjust the coming air in the dryer.

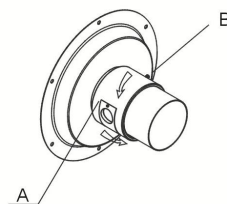

Picture 2-18: Working Principle



Caution!

If there happens to be no moisture drainage bore on the air inlet pipe of filter barrel, please drill one or contact our company directly.

2.2.7.3 Installation Steps

1. Installation of Filter and Dust Collecting Barrel

- 1) Mount the three spring clips of the assembly parts (4) on a proper place of filter barrel at first.
- 2) Mount filter (5) inside the filter barrel (1) and lock it with lockup washer (6), flat washer (7) and butterfly nut (8).
- 3) Install dust collecting barrel and lock it up with spring clip.
- 4) Mount the flange (2) for air inlet pipe and lock it with screw (3).

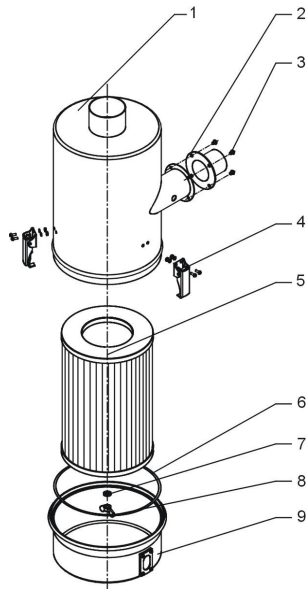

Picture 2-19: Installation of Filter and Dust Collecting Barrel

2. Installations of the Assembly Parts for the Cylinder Filter

- 1) First install filter barrel components (3) the bolt is installed in the installation board of filtering bucket.
- 2) Tighten up the fixing screw (1).

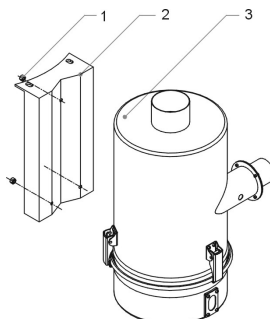

Picture 2-20: Installation of the Assembly Parts for the Cylinder Filter

3. Install "Euro" Hot Air Recycler on Hopper Dryer

- 1) Put hot air recycler (3) on a proper place of hopper dryer (1), and confirm the location of installation bores on the aluminum ring of the hopper dryer (1).
- 2) Drill out respective installation bores.
- 3) Mount on the hot air recycler (3), lock up the fixing screw (2).

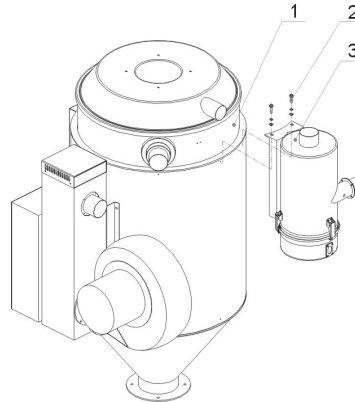

Picture 2-21: Install "Euro" Hot Air Recycler on Hopper Dryer

4. Installation of the Flange of Blower Inlet

- 1) First insert the aluminum made air volume adjusting ring assembly parts (4) onto the coupling flange (2), to align the air adjusting bore, then screw the insertive screw (5).
- 2) Mount coupling flange at the blower's air inlet (5), tighten up the screw (3).



Warning!

If blower has standard flange, please disassembly it.

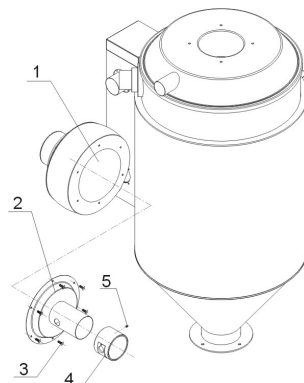

Picture 2-22: Installation of the Flange of Blower Inlet

5. Connection of Air Pipe

- 1) Mount on air pipe in suitable size according.

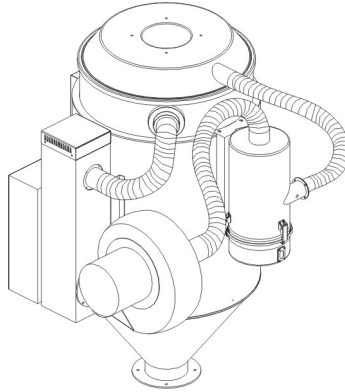

Picture 2-23: Connection of Air Pipe

2.2.7.4 Clean up the "Euro" Hot Air Recycler

- 1) Loosen the spring clip (1), and take out the dust collecting barrel (4) of the hot air recycler.
- 2) Unscrew the butterfly nut (3), and take out the filter (2) then clean it with a high pressure air jetter.
- 3) Install the filter in opposite steps.

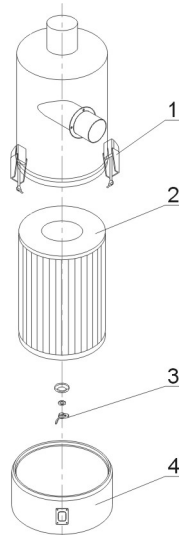

Picture 2-24: Clean up the "Euro" Hot Air Recycler

2.2.8 ADC-U "Euro" Air Filter

ADC-U "Euro" air filter can 100% avoid the dust discharging. This machine features simple structure and easier for installation. The built-in filter can keep the air within the plant clean and improves the production efficiency.



Model: ADC-80U

Picture 2-25: "Euro" Air Filter

Features:

1. Keep the air in the plant clean so can ensure production quality.
2. 100% avoid the dust discharging.
3. Economical and less space occupation, can work on the original "Euro" hopper dryer.
4. Beautiful appearance, optimal structure and especially easy for installation.

2.2.8.1 ADC-U Technical Specification

1) ADC-U Specifications

Table 2-5: ADC-U Specifications

Model	Filtering Barrel Dia.(Mm)	Air inlet Pipe Dia.	Air Outlet Pipe Dia.	Applicable Models	Fixed Plate
ADC-20U	120	1.5"	2"	SHD-20U	SHD-20U
ADC -40U				SHD-40U	SHD-40U
ADC -80U	225	2"	3"	SHD-80U~120U	SHD-80U~120U
ADC -160U	225	2.5"	3"	SHD-160U~230U	SHD-160U~230U
ADC -300U	225	2.5"	4"	SHD-300U~450U	SHD-300U~450U
ADC -600U	225	3"		SHD-600U~750U	SHD-600U~750U
ADC -900U	225	4"		SHD-900U~1200U	SHD-900U~1200U
ADC-1500U	280	5	5	SHD-1500U~2000U	SHD-1500U~2000U
ADC-2500U	340	6	6	SHD-2500U~3500U	SHD-2500U~3500U

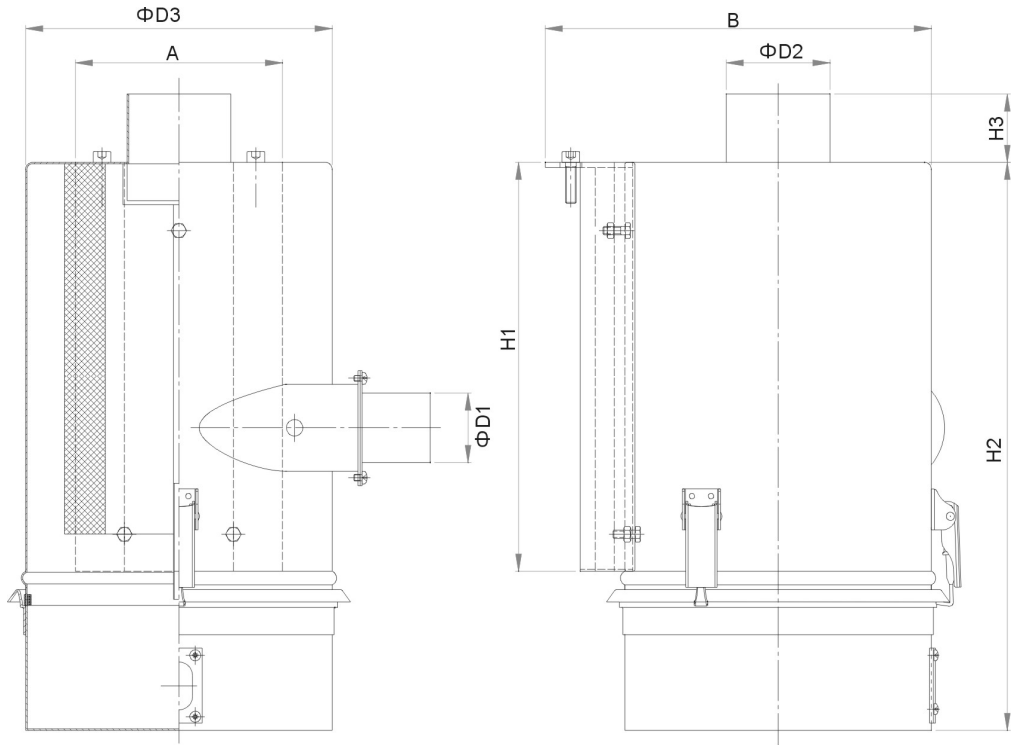

Picture 2-26: ADC-U Technical Specifications

2) ADC-U Technical Specifications

Table 2-6: ADC-U Out Dimensions

Model	A(mm)	B(mm)	D1(mm)	D2(mm)	D3(mm)	H1(mm)	H2(mm)	H3(mm)
ADC -20U	92	253	38	50.8	128	170	362	50
ADC -40U		217						
ADC -80U	152	314	51	76.2	225	303	405	50
ADC -120U								
ADC -160	152	314	63.5	76.2	225	303	405	50
ADC -230U								
ADC -300U	152	310	63.5	101.6	225	345	450	50
ADC -450U								
ADC -600U	152	322	76.2	101.6	225	345	450	50
ADC 750U								
ADC -900U	152	322	101.6	101.6	225	345	450	50
ADC -1200U								
ADC-1500U	240	393	127	127	280	290	705	100
ADC-2500U	200	490	152.4	152.4	340	605	818	240

2.2.8.2 Working Principle

ADC-U "Euro" air filter can 100% avoid the dust discharging. This machine features simple structure and easier for installation. The built-in cylinder filter can keep the air within the plant clean and improves the production efficiency.

2.2.8.3 Installation Steps

1. Installation of Filter and Dust Collecting Barrel

- 1) Mount the three spring clips of the assembly parts (4) on a proper place of filter barrel at first.
- 2) Mount filter (5) inside the filter barrel (1) and lock it with lockup washer (6), flat washer (7) and butterfly nut (8).
- 3) Install dust collecting barrel and lock it up with spring clip.
- 4) Mount the flange (2) for air inlet pipe and lock it with screw (3).

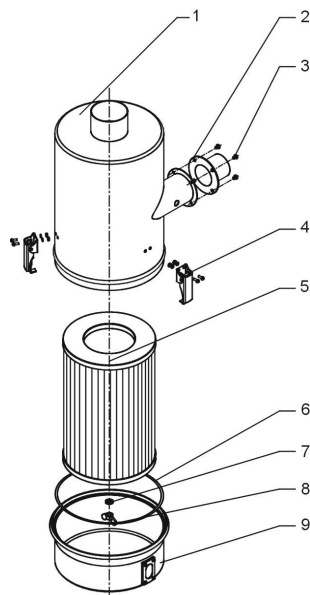

Picture 2-27: Installation of Filter and Dust Collecting Barrel

2. Installations of the Assembly Parts for the Cylinder Filter

- 1) First install filter barrel components (3) the bolt is installed in the installation board of filtering bucket.
- 2) Tighten up the fixing screw (1).

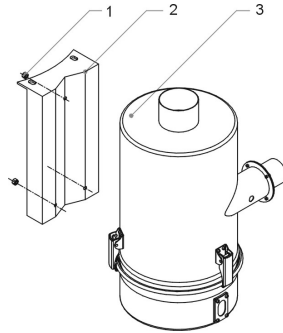

Picture 2-28: Installation of the Assembly Parts for the Cylinder Filter

3. Install "Euro" Hot Air Recycler on Hopper Dryer

- 1) Put hot air recycler (3) on a proper place of hopper dryer (1), and confirm the location of installation bores on the aluminum ring of the hopper dryer (1).
- 2) Drill out respective installation bores.
- 3) Mount on the hot air recycler (3), lock up the fixing screw (2).

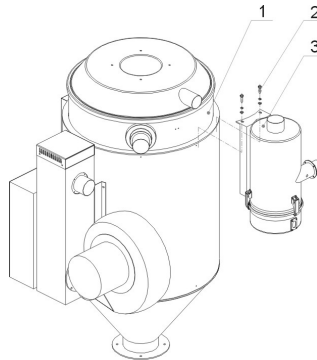

Picture 2-29: Install "Euro" Hot Air Recycler on Hopper Dryer

4. Installation of the Flange of Blower Inlet

- 1) First insert the aluminum made air volume adjusting ring assembly parts (4) onto the coupling flange (2), to align the air adjusting bore , then screw the insertive screw (5).
- 2) Mount coupling flange at the blower's air inlet (5), tighten up the screw (3).



Warning!

If blower has standard flange, please disassembly it.

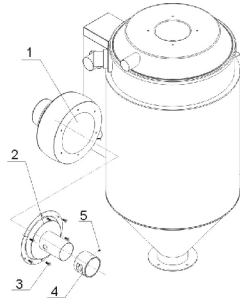

Picture 2-30: Installation of the Flange of Blower Inlet

5. Connection of Air Pipe

1) Mount on air pipe in suitable size according.

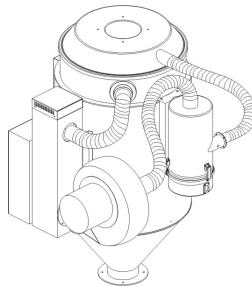

Picture 2-31: Connection of Air Pipe

2.2.8.4 Clean up the "Euro" Hot Air Recycler

- 1) Loosen the spring clip (1), and take out the dust collecting barrel (4) of the hot air recycler.
- 2) Unscrew the butterfly nut (3), and take out the filter (2) then clean it with a high pressure air jetter.
- 3) Install the filter in opposite steps.

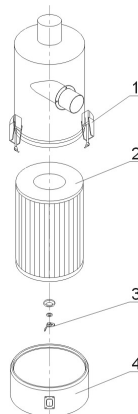

Picture 2-32: Clean up the "Euro" Hot Air Recycler

3. Installation Testing

3.1 Machine Location

3.1.1 Install Directly on a Moulding Machine

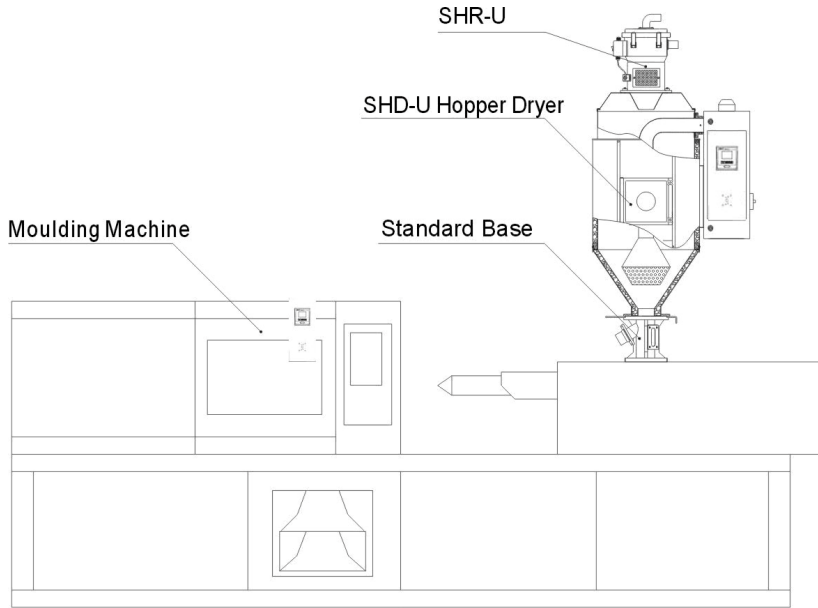

Picture 3-1: Install Directly on a Moulding Machine

3.1.2 To be used with Hopper Loaders

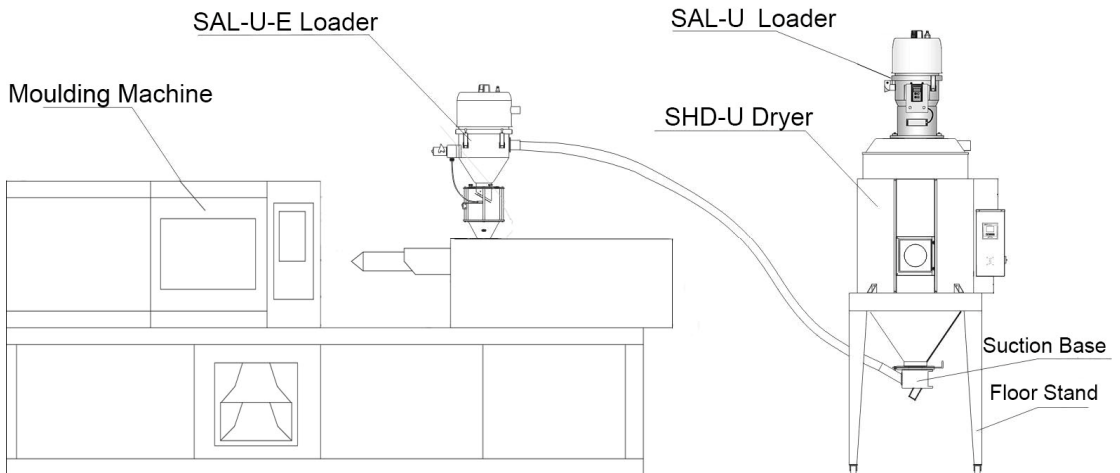

Picture 3-2: To be used with Hopper Loaders

3.2 Power Connectors

- 1) Make sure voltage and frequency of the power source comply with those indicated on the manufacture's plate, which is attached to the machine.
- 2) Power cable and earth connections should conform with local regulations.
- 3) Use independent power cable and ON / OFF switch. The cable's size should not smaller than those applied in the control box.
- 4) The power cable connection terminals should be tightened securely.
- 5) The machine requires a 3-phase 4-wire power source, connect the power lead (L1, L2, L3) to the live wires, and the earth (PE) to the ground.
- 6) Power supply requirements:
 - Main power voltage: $\pm 5\%$
 - Main power frequency: $\pm 2\%$
- 7) Specific power supply specifications please refer to the schematic model.

4. Application and Operation

4.1 Control Panel



Picture 4-1: Control Panel

4.1.1 Panel Operation

- 1) Turn on main power switch of control box.
- 2) Press "ON/OFF" key, it starts drying process, indicator turns green;
- 3) Press "ON/OFF" key again, it stops drying process, indicator turns yellow

4.1.2 Temperature Setting

- 1) The SV(Set value) will flash after pressing "Menu" key, increase or decrease temperature by pressing "Up" or "Down" key.
- 2) Press "Enter" key again to confirm the input value.

4.1.3 Temperature Lock

- 1) Press "Menu" key for 2 seconds, it displays "TIME".
- 2) Press "Up" key repeatedly, till it display "LOCK";
- 3) Press "Enter" key, the set value will flash, press "Up" or "Down" key to select "YES"(lock temperature setting) and "NO" (Unlock).
- 4) Press "Enter" key to confirm the input value.
- 5) Press "Menu" key to return operation menu.

Notes: When "LOCK" is set as "YES, temperature setting value will be locked which not accessible to change.



4.1.4 PID Setting

- 1) Press both “Menu” and “Down” keys for 3 seconds, it shows “P” (proportion) setting;



- 2) Press "Enter" key, the set value will flash, then press “Up”or “Down” key to increase or decrease the value.
- 3) Press "Enter" key to confirm the input value.
- 4) Press “Up” key again and again, it displays “I” (integral time) and “D” (differential time) setting accordingly.
- 5) Repeat above step 2 and step 3, input and confirm related parameters.
- 6) Press “Menu” key, it returns operation menu.

Notes: The PID parameter will directly influence the effect of temperature control, please be careful to set the value.

Parameters	Codes	Factory Default
Proportion	P	5
Integral time	I	200
Differential time	D	30
Over-temp alarm	OTP	15°C
Control cycle	HCLE	15
Blower delay	FDLY	180
Temp. unit	UNIT	°C

4.1.5 Intermittent Operation Setting

- 1) Hold “Menu” for about 2 secs. to set current time and week. Press “Up” or “Down” key to set start/stop function of AUTO timer, the time for RONE intermittent operation, the OFF time of ROFF intermittent operation, the ON time of RON intermittent operation.

4.1.6 One-week Timing Setting

- 1) After current time is set, hold “menu” for about 5 secs, press “Up” or “Down” key to set OFF1 (Mon. off time), OFF2(Tues. off time), OFF3 (Wed. off time), OFF4(Thur. off time), OFF 5(Fri. off time), OFF6(Sat. off time), OFF7(Sun.off time).
- 2) Hold “Menu” for about 7S, press “Up” or “Down” key to set ON1(Mon. start time), ON2(Tues. start time), ON3(Wed. start time), NO4(Thur. start time), ON5(Fri. start time), ON6(Sat. start time), ON7(Sun. start time).

4.1.7 Communication Setting (optional functions)

- 1) Press both “Menu” and “Up” for 3 seconds, it displays “PRO”(communication protocol) setting.

(Notes: communication protocol is fixed to Modbus RTU protocol—“RTU”).



- 2) Press “Up” key to enter “ID” (communication address) setting;
(Notes: The communication address of every controller in the same system must be the only one, no repeat use. In principle: communication address of hopper 1 is 1, communication address of hopper 1 is 2, and so on.)
- 3) Press “Setup” key, the set value flickers, then press “Up” or “Down” key to increase or decrease the value.
- 4) Press "Enter" key to confirm the input value;

- 5) Press “Up” key again and again, it displays “Baud” and “PAR” settings, (as below)
- 6) Repeat step 3 and step 4, then confirm the related input parameters.
- 7) Press “Menu” key to return operation menu.

Communication Parameters	Communication Codes	Factory Default
Communication Protocol	PRO	RTU
Communication Address	Id	1(current address)
Baud Rate	Baud	19.2K
PAR	PAR	none
Data Length	Data	8
Stop Bit	Stop	1

4.1.8 Operation Flow

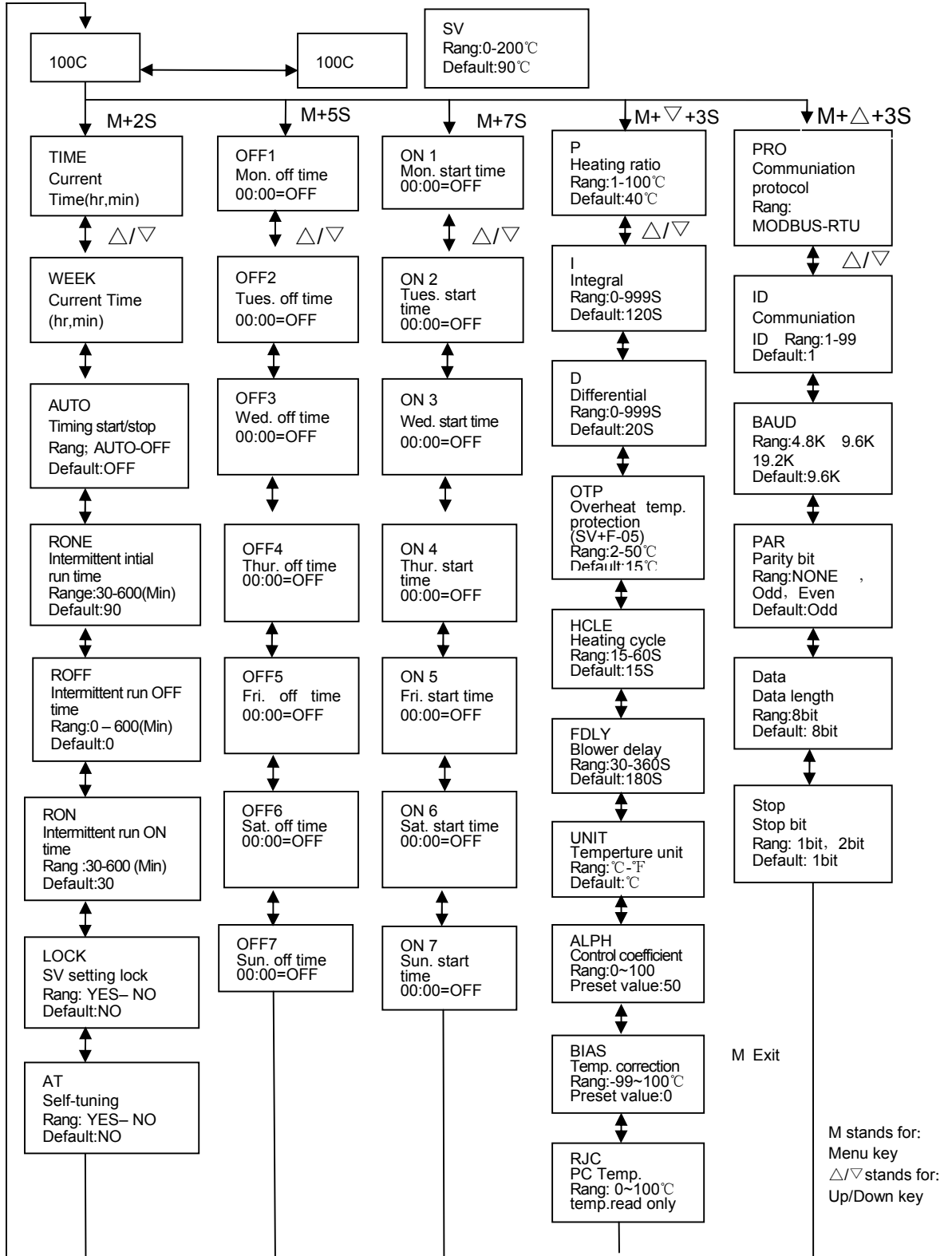

4.1.9 Wrong Codes Remark

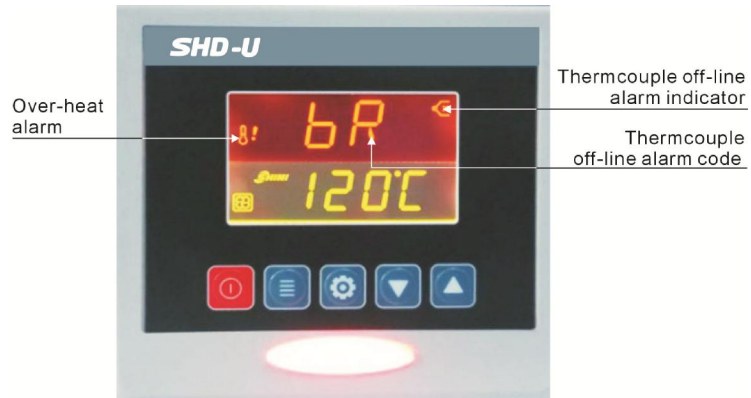

Wrong Codes	Remark
bR	Thermocouple off-line alarm
oH	Over-heat alarm
oL	Overload alarm
EGO	EGO Over-temp heater cable cut off

5. Trouble-shooting

Symptom	Possible causes	Actions taken
The rotating direction of blower fan is not as indicated.	Blower phase-reversal	Exchange two of the electrical wires
Blower can not be started.	1. Motor failures 2. Failures of contactor	1. Repair or replace 2. Replace or reset
The blower and heater can not work.	1. Tripping of overload relay 2. Problems of transformer 3. Fuse melted 4. Troubles of power	1. Check or replace 2. Check or replace 3. Check or replace 4. Check for anti-phase
The blower can work, but heater can not.	1. Lead bridge of heater 2. Problems of contactor 3. Heater problems 4. Temp. controller problems(No output) 5. Thermocouple problems	1. Check or replace 2. Check or replace 3. Check or replace 4. Check or replace 5. Replace thermocouple
The blower is working, but drying temperature will not increase.	1. Poor connection of heater 2. Short circuit of overheat protector or tripping off 3. Phase shortage of contactor 4. Temp. controller damaged.	1. Check or place lead bridge and heater 2. Repair or reset 3. Repair or replace 4. Replace temp. controller
The blower can work, but the temp. Is too high.	1. Hot air pipe jammed 2. Errors or problems of the temp. controller	1. Cleaning 2. Replace temp. controller or adjust the knob



Note!

Main switch must be turned "OFF" when checking or replacing the components of the machine.

6. Maintenance and Repair

SHD-20U~1200U

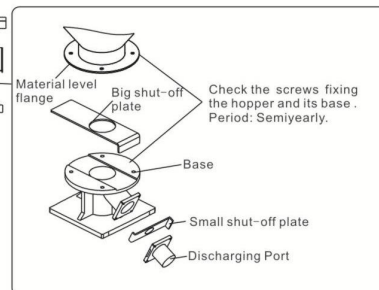
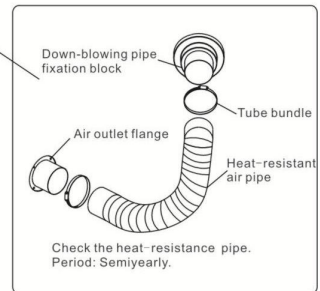
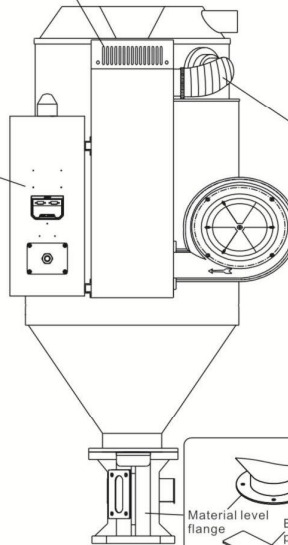
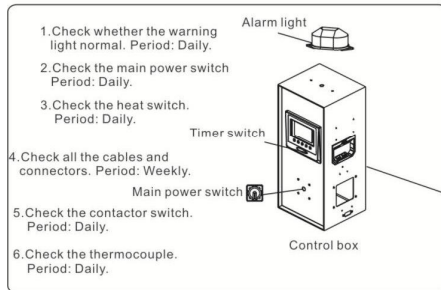
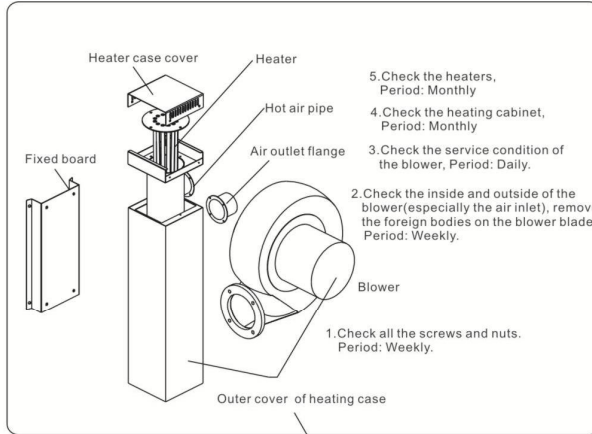

SHD-1500U~8000U

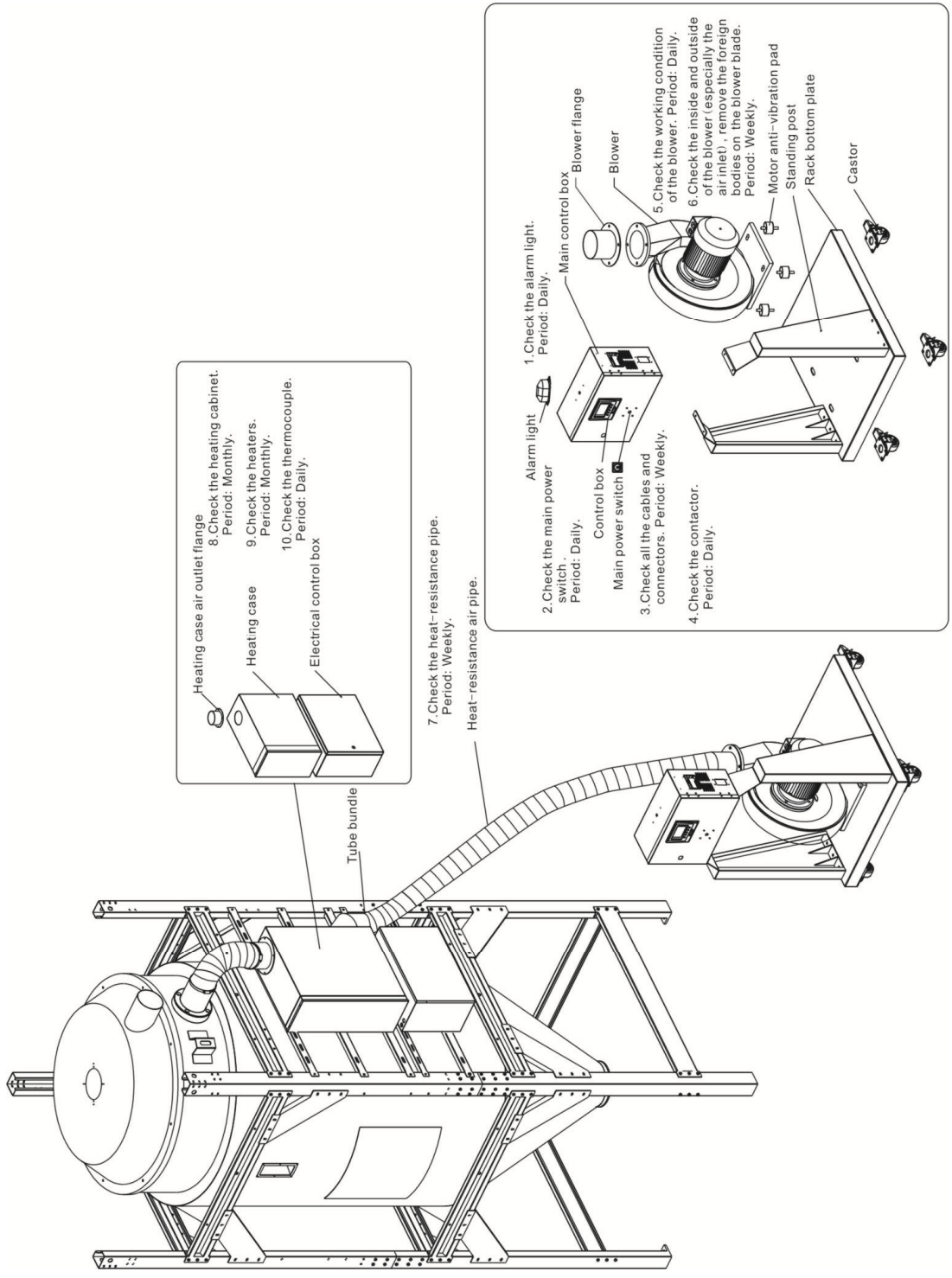

8. Check the heating cabinet.
Period: Monthly.

9. Check the heaters.
Period: Monthly.

10. Check the thermocouple.
Period: Daily.

7. Check the heat-resistance pipe.
Period: Weekly.

1. Check the alarm light.
Period: Daily.

2. Check the main power switch.
Period: Daily.

3. Check all the cables and connectors.
Period: Weekly.

4. Check the contactor.
Period: Daily.

5. Check the working condition of the blower.
Period: Daily.

6. Check the inside and outside of the blower (especially the air inlet), remove the foreign bodies on the blower blade.
Period: Weekly.

SHD-40U~80U-HD

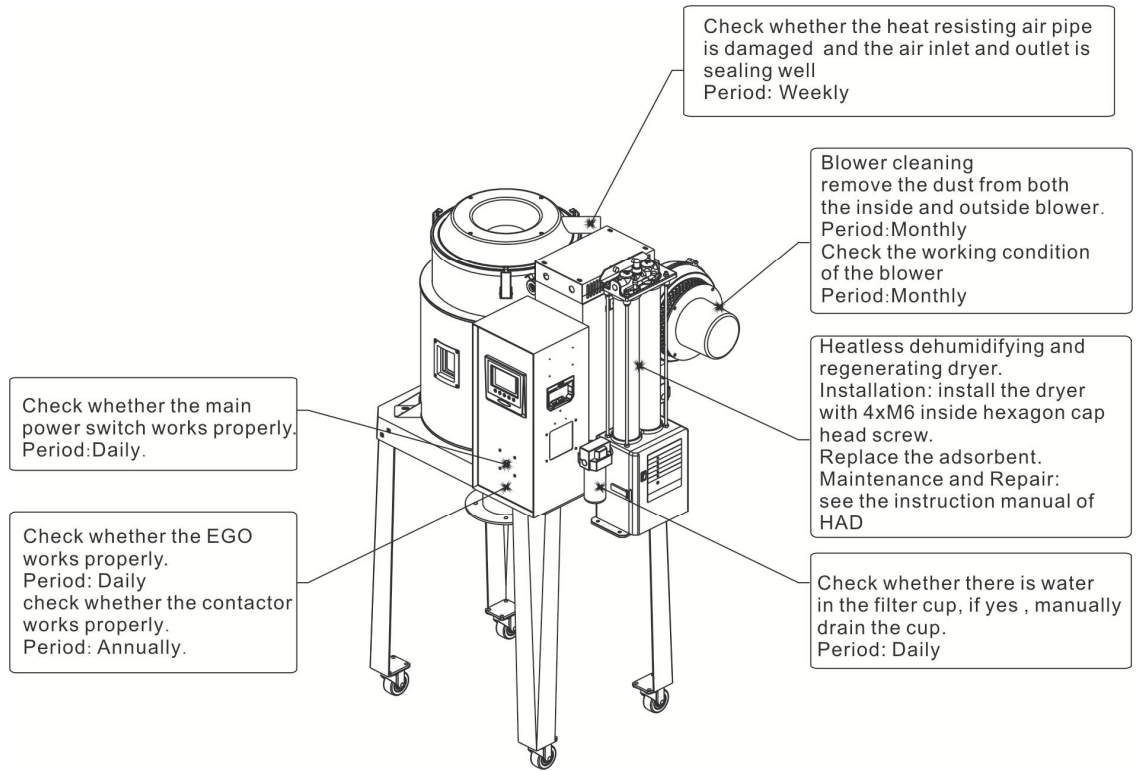

6.1 Blower

- 1) Clean inner and outer parts (especially at blower inlet) of the blower periodically.
- 2) Remove the dusts on leaves of the fan.

6.2 Maintenance Schedule

6.2.1 General Machine Information

Model _____ SN _____ Manufacture date _____

Voltage _____ Φ _____ V Frequency _____ Hz Power _____ kW

6.2.2 Installation & Inspection

- Check if the pipe joint is tightly locked by clips or not.
- Check that the material clearance door is firmly closed.
- Check that the piping system is correctly connected.

Electrical Installation

- Voltage: _____ V _____ Hz
- Fuse melt current: 1 Phase _____ A 3 Phase _____ A
- Check phase sequence of the power supply.
- Check the rotating direction of the blower.

6.2.3 Daily Checking

- Check the switches of the machine.
- Check auto-start function of the machine.

6.2.4 Weekly Checking

- Check all the electrical cables of the machine.
- Check if there are loose electrical connections.

6.2.5 Monthly Checking

- Check that the pipe heater is working properly.
- Check the performance of blower.
- Check the functions of electrical components.

6.2.6 Half-yearly Checking

- Check if there are damages of heat-resistant hose or not.
- Check the process heater.
- Check the blower.