

SIC-A-R2

Air-cooled Water Chiller

Date: Feb, 2014

Version: Ver.B (English)



Contents

1. General Description	20
1.1 Coding Principle	21
1.2 Main Features.....	21
1.3 Technical Specifications	24
1.3.1 External Dimensions of SIC-A-R2	24
1.3.2 Specification List	26
1.4 Safety Regulations	27
1.4.1 Security Labels.....	27
1.4.2 Signs and Labels.....	27
1.5 Exemption Clause	28
2. Structural Features and Working Principle	29
2.1 Main Functions	29
2.1.1 Working Principle	29
2.2 Parts Drawing	31
2.2.1 Structure Chart (SIC-7.5A-R2)	31
2.2.2 Structure Chart Parts List (SIC-7.5A-R2)	32
2.2.3 Water System Diagram (SIC-7.5A-R2)	33
2.2.4 Water System Parts List (SIC-7.5A-R2)	34
2.2.5 Refrigerant System Diagram (SIC-7.5A-R2)	35
2.2.6 Refrigerant System Parts List (SIC-7.5A-R2).....	36
2.2.7 General Assembly Diagram (SIC-7.5A-R2).....	37
2.2.8 General Assembly Parts List (SIC-7.5A-R2)	38
2.2.9 Racking Diagram (SIC-12A-R2).....	39
2.2.10 Rack Parts List (SIC-12A-R2)	40
2.2.11 Water System Diagram (SIC-12A-R2)	41
2.2.12 Water System Parts List (SIC-12A-R2).....	42
2.2.13 Refrigerant System Diagram (SIC-12A-R2)	43
2.2.14 Refrigerant System Parts List (SIC-12A-R2).....	44
2.2.15 Rack Diagram (SIC-12A-R2).....	45
2.2.16 Rack Parts List (SIC-12A-R2)	46
2.2.17 Rack Diagram (SIC-18A-R2~24A-R2)	47

2.2.18 Rack Parts List (SIC-18A-R2~24A-R2)	48
2.2.19 Water System Diagram (SIC-18A-R2~24A-R2)	49
2.2.20 Water System Parts List (SIC-18A-R2~24A-R2).....	50
2.2.21 Refrigerant System Diagram (SIC-18A-R2~24A-R2)	51
2.2.22 Refrigerant System Parts List (SIC-18A-R2~24A-R2).....	52
2.2.23 Genmeral Assembly Diagram (SIC-18A-R2~24A-R2)	53
2.2.24 Genmeral Assembly Parts List (SIC-18A-R2~24A-R2)	54
2.2.25 Rack Diagram (SIC-28A-R2~38A-R2)	55
2.2.26 Rack Parts List (SIC-28A-R2~38A-R2).....	56
2.2.27 Water System & Refrigerant system Diagram (SIC-28A-R2~38A-R2).....	57
2.2.28 Water System & Refrigerant system Parts List (SIC-28A-R2~38A-R2).....	58
2.2.29 Rack Diagram (SIC-48A-R2~75A-R2)	59
2.2.30 Rack Parts List (SIC-48A~75A -R2).....	60
2.2.31 Water System Diagram (SIC-48A-R2~75A-R2)	61
2.2.32 Water System Parts List (SIC-48A-R2~75A-R2).....	62
2.2.33 Refrigerant System Diagram (SIC-48A-R2~75A-R2)	63
2.2.34 Refrigerant Sytem Parts List (SIC-48A-R2~75A-R2)	64
2.2.35 General Assembly Disgram (SIC-48A-R2~75A-R2).....	65
2.2.36 General Assemble Diagram Parts List (SIC-48A-R2~75A-R2) ...	66
2.2.37 Rack Diagram (SIC-100A-R2).....	67
2.2.38 Rack Parts List (SIC-100A-R2)	68
2.2.39 Water System Diagram (SIC-100A-R2)	69
2.2.40 Water System Parts List (SIC-100A-R2).....	70
2.2.41 Refrigerant System Diagram (SIC-100A-R2)	71
2.2.42 Refrigerant Sytem Parts List (SIC-100A-R2).....	72
2.2.43 General Assembly Disgram (SIC-100A-R2).....	73
2.2.44 General Assembly Diagram Parts List (SIC-100A-R2).....	74
2.2.45 Rack Diagram (SIC-114A-R2).....	75
2.2.46 Rack Parts List (SIC-114A-R2)	76
2.2.47 Water System Diagram (SIC-114A-R2)	77
2.2.48 Water System Parts List (SIC-114A-R2).....	78
2.2.49 Refrigerant System Diagram (SIC-114A-R2)	79

2.2.50 Refrigerant Sytem Parts List (SIC-114A-R2).....	80
2.2.51 General Assembly Disgram (SIC-114A-R2).....	81
2.2.52 General Assembly Diagram Parts List (SIC-114A-R2).....	82
2.2.53 Main Parts and Functions	83
2.3 Electrical Circuit.....	89
2.3.1 Selection Table of Pump Contactor and Thermal Overload Relay (400V).....	89
2.3.2 Main Electrical Circuit (SIC-7.5A-R2) (400V)	92
2.3.3 Control Circuit (SIC-7.5A-R2) (400V).....	93
2.3.4 Electrical Components Layout (SIC-7.5A-R2) (400V)	94
2.3.5 Electrical Components List (SIC-7.5A-R2) (400V)	95
2.3.6 Main Electrical Circuit (SIC-12A-R2) (400V)	97
2.3.7 Control Circuit (SIC-12A-R2) (400V).....	98
2.3.8 Electrical Components Layout (SIC-12A-R2) (400V)	99
2.3.9 Electrical Components List (SIC-12A-R2) (400V)	100
2.3.10 Main Electrical Circuit (SIC-18A-R2) (400V)	101
2.3.11 Control Circuit (SIC-18A-R2) (400V).....	102
2.3.12 Electrical Components Layout (SIC-18A-R2) (400V)	103
2.3.13 Electrical Components List (SIC-18A-R2) (400V)	104
2.3.14 Main Electrical Circuit (SIC-24A-R2) (400V)	105
2.3.15 Control Circuit (SIC-24A-R2) (400V).....	106
2.3.16 Electrical Components Layout (SIC-24A-R2) (400V)	107
2.3.17 Electrical Components List (SIC-24A-R2) (400V)	108
2.3.18 Main Electrical Circuit (SIC-28A-R2) (400V)	109
2.3.19 Control Circuit (SIC-28A-R2) (400V).....	110
2.3.20 Electrical Components Layout (SIC-28A-R2) (400V)	111
2.3.21 Electrical Components List (SIC-28A-R2) (400V)	112
2.3.22 Main Electrical Circuit (SIC-38A-R2) (400V)	114
2.3.23 Control Circuit (SIC-38A-R2) (400V).....	115
2.3.24 Electrical Components Layout (SIC-38A-R2) (400V)	116
2.3.25 Electrical Components List (SIC-38A-R2) (400V)	117
2.3.26 Main Electrical Circuit (SIC-48A-R2) (400V)	119
2.3.27 Control Circuit (SIC-48A-R2) (400V).....	120
2.3.28 Electrical Components Layout (SIC-48A-R2) (400V)	121

2.3.29 Electrical Components List (SIC-48A-R2) (400V)	122
2.3.30 Main Electrical Circuit (SIC-58A-R2) (400V)	124
2.3.31 Control Circuit (SIC-58A-R2) (400V)	125
2.3.32 Electrical Components Layout (SIC-58A-R2) (400V)	126
2.3.33 Electrical Components List (SIC-58A-R2) (400V)	127
2.3.34 Main Electrical Circuit (SIC-75A-R2) (400V)	129
2.3.35 Control Circuit (SIC-75A-R2) (400V)	130
2.3.36 Electrical Components Layout (SIC-75A-R2) (400V)	131
2.3.37 Electrical Components List (SIC-75A-R2) (400V)	132
2.3.38 Main Electrical Circuit (SIC-100A-R2) (400V)	134
2.3.39 Control Circuit (SIC-100A-R2) (400V)	137
2.3.40 Electrical Components Layout (SIC-100A-R2) (400V)	141
2.3.41 Electrical Components List (SIC-100A-R2) (400V)	144
2.3.42 Main Electrical Circuit (SIC-114A-R2) (400V)	146
2.3.43 Control Circuit (SIC-114A-R2) (400V)	149
2.3.44 Electrical Components Layout (SIC-114A-R2) (400V)	153
2.3.45 Electrical Components List (SIC-114A-R2) (400V)	156
2.3.46 Selection Table of Pump Contactor and Thermal Overload Relay (230V)	158
2.3.47 Main Electrical Circuit (SIC-7.5A-R2) (230V)	160
2.3.48 Control Circuit (SIC-7.5A-R2) (230V)	161
2.3.49 Electrical Components Layout (SIC-7.5A-R2) (230V)	162
2.3.50 Electrical Components List (SIC-7.5A-R2) (230V)	163
2.3.51 Main Electrical Circuit (SIC-12A-R2) (230V)	165
2.3.52 Control Circuit (SIC-12A-R2) (230V)	166
2.3.53 Electrical Components Layout (SIC-12A-R2) (230V)	167
2.3.54 Electrical Components List (SIC-12A-R2) (230V)	168
2.3.55 Main Electrical Circuit (SIC-18A-R2) (230V)	169
2.3.56 Control Circuit (SIC-18A-R2) (230V)	170
2.3.57 Electrical Components Layout (SIC-18A-R2) (230V)	171
2.3.58 Electrical Components List (SIC-18A-R2) (230V)	172
2.3.59 Main Electrical Circuit (SIC-24A-R2) (230V)	173
2.3.60 Control Circuit (SIC-24A-R2) (230V)	174
2.3.61 Electrical Components Layout (SIC-24A-R2) (230V)	175

2.3.62	Electrical Components List (SIC-24A-R2) (230V)	176
2.3.63	Main Electrical Circuit (SIC-28A-R2) (230V)	178
2.3.64	Control Circuit (SIC-28A-R2) (230V)	179
2.3.65	Electrical Components Layout (SIC-28A-R2) (230V)	180
2.3.66	Electrical Components List (SIC-28A-R2) (230V)	181
2.3.67	Main Electrical Circuit (SIC-38A-R2) (230V)	182
2.3.68	Control Circuit (SIC-38A-R2) (230V)	183
2.3.69	Electrical Components Layout (SIC-38A-R2) (230V)	184
2.3.70	Electrical Components List (SIC-38A-R2) (230V)	185
2.3.71	Main Electrical Circuit (SIC-48A-R2) (230V)	187
2.3.72	Control Circuit (SIC-48A-R2) (230V)	188
2.3.73	Electrical Components Layout (SIC-48A-R2) (230V)	189
2.3.74	Electrical Components List (SIC-48A-R2) (230V)	190
2.3.75	Main Electrical Circuit (SIC-58A-R2) (230V)	192
2.3.76	Control Circuit (SIC-58A-R2) (230V)	193
2.3.77	Electrical Components Layout (SIC-58A-R2) (230V)	194
2.3.78	Electrical Components List (SIC-58A-R2) (230V)	195
2.3.79	Main Electrical Circuit (SIC-75A-R2) (230V)	197
2.3.80	Control Circuit (SIC-75A-R2) (230V)	198
2.3.81	Electrical Components Layout (SIC-75A-R2) (230V)	199
2.3.82	Electrical Components List (SIC-75A-R2) (230V)	200
2.3.83	Main Electrical Circuit (SIC-100A-R2) (230V)	202
2.3.84	Control Circuit (SIC-100A-R2) (230V)	205
2.3.85	Electrical Components Layout (SIC-100A-R2) (230V)	209
2.3.86	Electrical Components List (SIC-100A-R2) (230V)	212
2.3.87	Main Electrical Circuit (SIC-114A-R2) (230V)	214
2.3.88	Control Circuit (SIC-114A-R2) (230V)	217
2.3.89	Electrical Components Layout (SIC-114A-R2) (230V)	221
2.3.90	Electrical Components List (SIC-114A-R2) (230V)	224
2.4	Main Electrical Components	225
2.4.1	Thermal Overload Relay	225
3.	Installation and Debugging	226
3.1	Installation Notices	226
3.2	Schematic Drawing of Installation	227

3.3	Power Supply	227
4.	Application and Operation	229
4.1	Control Panel.....	229
4.2	Machine startup	231
4.3	Machine Shutdown	232
4.4	Thermostat 1	233
4.4.1	Temperature Setting	233
4.4.2	Default Setting Table.....	234
4.4.3	Code Meanings.....	234
5.	Trouble-shooting	235
6.	Maintenance and Repair.....	238
6.1	Fill in the Refrigerant	240
6.2	Components Maintenance.....	241
6.2.1	Condenser	241
6.2.2	Evaporator	242
6.3	Maintenance Schedule	243
6.3.1	About the Machine	243
6.3.2	Check after Installation.....	243
6.3.3	Daily Checking	243
6.3.4	Weekly Checking	243
6.3.5	Montly Checking.....	243
6.3.6	Trimonthly Checking	243
6.3.7	Half-yearly Checking	244
6.3.8	Yearly Checking	244
6.3.9	3 year Checking	244

Table Index

Table 1-1:	Specifications	25
Table 1-2:	Specification List	26
Table 2-1:	Structure Chart Parts List (SIC-7.5A-R2).....	32
Table 2-2:	Water System Parts List (SIC-7.5A-R2)	34

Table 2-3: Refrigerant System Parts List (SIC-7.5A-R2)	36
Table 2-4: General Assembly Parts List (SIC-7.5A-R2).....	38
Table 2-5: Rack Parts List (SIC-12A-R2).....	40
Table 2-6: Water System Parts List (SIC-12A-R2)	42
Table 2-7: Refrigerant System Parts List (SIC-12A-R2)	44
Table 2-8: Rack Parts List (SIC-12A-R2).....	46
Table 2-9: Rack Parts List (SIC-18A-R2~24A-R2)	48
Table 2-10: Water System Parts List (SIC-18A-R2~24A-R2)	50
Tabel 2-11: Refrigerant System Parts List (SIC-18A-R2~24A-R2).....	52
Table 2-12: Genmeral Assembly Parts List (SIC-18A-R2~24A-R2)	54
Table 2-13: Rack Parts List (SIC-28A-R2~38A-R2)	56
Table 2-14 : Water System & Refrigerant system Parts List (SIC-28A-R2~38A-R2).....	58
Table 2-15: Rack Parts List (SIC-48A~75A -R2).....	60
Table 2-16: Water System Parts List (SIC-48A-R2~75A-R2)	62
Table 2-17: Refrigerant Sytem Parts List (SIC-48A-R2~75A-R2).....	64
Table 2-18: General Assemble Diagram Parts List (SIC-48A-R2~75A-R2).....	66
Table 2-19: Rack Parts List (SIC-100A-R2).....	68

Table 2-20: Water System Parts List (SIC-100A-R2)	70
Table 2-21: Refrigerant Sytem Parts List (SIC-100A-R2)	72
Table 2-22: General Assemble Diagram Parts List (SIC-100A-R2)	74
Table 2-23: Rack Parts List (SIC-114A-R2).....	76
Table 2-24: Water System Parts List (SIC-114A-R2)	78
Table 2-25: Refrigerant System Parts List (SIC-114A-R2)	80
Table 2-26: General Assembly Diagram Parts List (SIC-114A-R2)	82
Table 2-27: Selection Table of Pump Contactor and Thermal Overload Relay (Low Pressure) (400V)	89
Table 2-28: Selection Table of Pump Contactor and Thermal Overload Relay (Medium Pressure) (400V).....	89
Table 2-29: Selection Table of Pump Contactor and Thermal Overload Relay (High Pressure) (400V)	91
Table 2-30: Electrical Components List (SIC-7.5A-R2) (400V).....	95
Table 2-31: Electrical Components List (SIC-12A-R2) (400V).....	100
Table 2-32: Electrical Components List (SIC-18A-R2) (400V).....	104
Table 2-33: Electrical Components List (SIC-24A-R2) (400V).....	108
Table 2-34: Electrical Components List (SIC-28A-R2) (400V).....	112
Table 2-35: Electrical Components List (SIC-38A-R2) (400V).....	117

Table 2-36: Electrical Components List (SIC-48A-R2) (400V).....	122
Table 2-37: Electrical Components List (SIC-58A-R2) (400V).....	127
Table 2-38: Electrical Components List (SIC-75A-R2) (400V).....	132
Table 2-39: Electrical Components List (SIC-100A-R2) (400V).....	144
Table 2-40: Electrical Components List (SIC-114A-R2) (400V).....	156
Table 2-41: Selection Table of Pump Contactor and Thermal Overload Relay (Low Pressure) (230V).....	158
Table 2-42: Selection Table of Pump Contactor and Thermal Overload Relay (Medium Pressure) (230V).....	158
Table 2-43: Selection Table of Pump Contactor and Thermal Overload Relay (High Pressure) (230V)	159
Table 2-44: Electrical Components List (SIC-7.5A-R2) (230V).....	163
Table 2-45: Electrical Components List (SIC-12A-R2) (230V).....	168
Table 2-46: Electrical Components List (SIC-18A-R2) (230V).....	172
Table 2-47: Electrical Components List (SIC-24A-R2) (230V).....	176
Table 2-48: Electrical Components List (SIC-28A-R2) (230V).....	181
Table 2-49: Electrical Components List (SIC-38A-R2) (230V).....	185
Table 2-50: Electrical Components List (SIC-48A-R2) (230V).....	190
Table 2-51: Electrical Components List (SIC-58A-R2) (230V).....	195

Table 2-52: Electrical Components List (SIC-75A-R2) (230V).....	200
Table 2-53: Electrical Components List (SIC-100A-R2) (230V).....	212
Table 2-54: Electrical Components List (SIC-114A-R2) (230V).....	224

Picture Index

Picture 1-1: Outline Dimensional Drawing.....	24
Picture 2-1: Working Principle Diagram	29
Picture 2-2: Structure Chart (SIC-7.5A-R2)	31
Picture 2-3: Water System Diagram (SIC-7.5A-R2).....	33
Picture 2-4: Refrigerant System Diagram (SIC-7.5A-R2)	35
Picture 2-5: General Assembly Diagram (SIC-7.5A-R2).....	37
Picture 2-6: Rack Diagram (SIC-12A-R2).....	39
Picture 2-7: Water System Diagram (SIC-12A-R2).....	41
Picture 2-8: Refrigerant System Diagram (SIC-12A-R2)	43
Picture 2-9: Rack Diagram (SIC-12A-R2).....	45
Picture 2-10: Rack Diagram (SIC-18A-R2~24A-R2).....	47
Picture 2-11: Water System Diagram (SIC-18A-R2~24A-R2)	49
Picture 2-12: Refrigerant System Diagram (SIC-18A-R2~24A-R2)	51
Picture 2-13: Genmeral Assembly Diagram (SIC-18A-R2~24A-R2).....	53

Picture 2-14: Sack Diagram (SIC-28A-R2~38A-R2).....	55
Picture 2-15 : Water System & Refrigerant system Diagram (SIC-28A-R2~38A-R2).....	57
Picture 2-16: Rack Diagram (SIC-48A-R2~75A-R2).....	59
Picture 2-17: Water System Diagram (SIC-48A-R2~75A-R2)	61
Picture 2-18: Refrigerant System Diagram (SIC-48A-R2~75A-R2)	63
Picture 2-19: General Assembly Disgram (SIC-48A-R2~75A-R2).....	65
Picture 2-20: Rack Diagram (SIC-100A-R2).....	67
Picture 2-21: Refrigerant System Diagram (SIC-100A-R2)	71
Picture 2-22: General Assembly Disgram (SIC-100A-R2).....	73
Picture 2-23: Rack Diagram (SIC-114A-R2).....	75
Picture 2-24: Water System Diagram (SIC-114A-R2).....	77
Picture 2-25: Refrigerant System Diagram (SIC-114A-R2)	79
Picture 2-26: General Assembly Disgram (SIC-114A-R2).....	81
Picture 2-27: Compressor.....	83
Picture 2-28: Condensor.....	83
Picture 2-29: Drying Filter	84
Picture 2-30: Heat Expansion Valve	84

Picture 2-31: Evaporator.....	85
Picture 2-32: High and Low Pressure Controller.....	85
Picture 2-33: Refrigerant Indicator.....	85
Picture 2-34: Solenoid Valve	86
Picture 2-35: Heat By-pass Valve.....	86
Picture 2-36: Flow Switch	87
Picture 2-37: Main Electrical Circuit (SIC-7.5A-R2) (400V).....	92
Picture 2-38: Control Circuit (SIC-7.5A-R2) (400V).....	93
Picture 2-39: Electrical Components Layout (SIC-7.5A-R2) (400V).....	94
Picture 2-40: Main Electrical Circuit (SIC-12A-R2) (400V).....	97
Picture 2-41: Control Circuit (SIC-12A-R2) (400V)	98
Picture 2-42: Electrical Components Layout (SIC-12A-R2) (400V)	99
Picture 2-43: Main Electrical Circuit (SIC-18A-R2) (400V).....	101
Picture 2-44: Control Circuit (SIC-18A-R2) (400V)	102
Picture 2-45: Electrical Components Layout (SIC-18A-R2) (400V)	103
Picture 2-46: Main Electrical Circuit (SIC-24A-R2) (400V).....	105
Picture 2-47: Control Circuit (SIC-24A-R2) (400V)	106
Picture 2-48: Electrical Components Layout (SIC-24A-R2) (400V)	107
Picture 2-49: Main Electrical Circuit (SIC-28A-R2) (400V)	109
Picture 2-50: Control Circuit (SIC-28A-R2) (400V)	110

Picture 2-51: Electrical Components Layout (SIC-28A-R2) (400V)	111
Picture 2-52: Main Electrical Circuit (SIC-38A-R2) (400V)	114
Picture 2-53: Control Circuit (SIC-38A-R2) (400V)	115
Picture 2-54: Electrical Components Layout (SIC-38A-R2) (400V)	116
Picture 2-55: Main Electrical Circuit (SIC-48A-R2) (400V)	119
Picture 2-56: Control Circuit (SIC-48A-R2) (400V)	120
Picture 2-57: Electrical Components Layout (SIC-48A-R2) (400V)	121
Picture 2-58: Main Electrical Circuit (SIC-58A-R2) (400V)	124
Picture 2-59: Control Circuit (SIC-58A-R2) (400V)	125
Picture 2-60: Electrical Components Layout (SIC-58A-R2) (400V)	126
Picture 2-61: Main Electrical Circuit (SIC-75A-R2) (400V)	129
Picture 2-62: Control Circuit (SIC-75A-R2) (400V)	130
Picture 2-63: Electrical Components Layout (SIC-75A-R2) (400V)	131
Picture 2-64: Main Electrical Circuit 1(SIC-100A-R2) (400V)	134
Picture 2-65: Main Electrical Circuit 2(SIC-100A-R2) (400V)	135
Picture 2-66: Control Circuit 1(SIC-100A-R2) (400V)	137
Picture 2-67: Control Circuit 2(SIC-100A-R2) (400V)	138

Picture 2-68: Control Circuit 3(SIC-100A-R2) (400V)	139
Picture 2-69: Electrical Components Layout 1(SIC-100A-R2) (400V)	141
Picture 2-70: Electrical Components Layout 2(SIC-100A-R2) (400V)	142
Picture 2-71: Main Electrical Circuit 1(SIC-114A-R2) (400V)	146
Picture 2-72: Main Electrical Circuit 2(SIC-114A-R2) (400V)	147
Picture 2-73: Control Circuit 1(SIC-114A-R2) (400V)	149
Picture 2-74: Control Circuit 2(SIC-114A-R2) (400V)	150
Picture 2-75: Control Circuit 3(SIC-114A-R2) (400V)	151
Picture 2-76: Electrical Components Layout 1(SIC-114A-R2) (400V)	153
Picture 2-77: Electrical Components Layout 2(SIC-114A-R2) (400V)	154
Picture 2-78: Main Electrical Circuit (SIC-7.5A-R2) (230V)	160
Picture 2-79: Control Circuit (SIC-7.5A-R2) (230V)	161
Picture 2-80: Electrical Components Layout (SIC-7.5A-R2) (230V)	162
Picture 2-81: Main Electrical Circuit (SIC-12A-R2) (230V)	165
Picture 2-82: Control Circuit (SIC-12A-R2) (230V)	166
Picture 2-83: Electrical Components Layout (SIC-12A-R2) (230V)	167
Picture 2-84: Main Electrical Circuit (SIC-18A-R2) (230V)	169
Picture 2-85: Control Circuit (SIC-18A-R2) (230V)	170
Picture 2-86: Electrical Components Layout (SIC-18A-R2) (230V)	171
Picture 2-87: Main Electrical Circuit (SIC-24A-R2) (230V)	173

Picture 2-88: Control Circuit (SIC-24A-R2) (230V)	174
Picture 2-89: Electrical Components Layout (SIC-24A-R2) (230V)	175
Picture 2-90: Main Electrical Circuit (SIC-28A-R2) (230V)	178
Picture 2-91: Control Circuit (SIC-28A-R2) (230V)	179
Picture 2-92: Electrical Components Layout (SIC-28A-R2) (230V)	180
Picture 2-93: Main Electrical Circuit (SIC-38A-R2) (230V)	182
Picture 2-94: Control Circuit (SIC-38A-R2) (230V)	183
Picture 2-95: Electrical Components Layout (SIC-38A-R2) (230V)	184
Picture 2-96: Main Electrical Circuit (SIC-48A-R2) (230V)	187
Picture 2-97: Control Circuit (SIC-48A-R2) (230V)	188
Picture 2-98: Electrical Components Layout (SIC-48A-R2) (230V)	189
Picture 2-99: Main Electrical Circuit (SIC-58A-R2) (230V)	192
Picture 2-100: Control Circuit (SIC-58A-R2) (230V)	193
Picture 2-101: Electrical Components Layout (SIC-58A-R2) (230V)	194
Picture 2-102: Main Electrical Circuit (SIC-75A-R2) (230V)	197
Picture 2-103: Control Circuit (SIC-75A-R2) (230V)	198
Picture 2-104: Electrical Components Layout (SIC-75A-R2) (230V)	199

Picture 2-105: Main Electrical Circuit 1(SIC-100A-R2) (230V).....	202
Picture 2-106: Main Electrical Circuit 2(SIC-100A-R2) (230V).....	203
Picture 2-107: Control Circuit 1(SIC-100A-R2) (230V)	205
Picture 2-108: Control Circuit 2(SIC-100A-R2) (230V)	206
Picture 2-109: Control Circuit 3(SIC-100A-R2) (230V)	207
Picture 2-110: Electrical Components Layout 1(SIC-100A-R2) (230V)	209
Picture 2-111: Electrical Components Layout 2(SIC-100A-R2) (230V)	210
Picture 2-112: Main Electrical Circuit 1(SIC-114A-R2) (230V).....	214
Picture 2-113: Main Electrical Circuit 2(SIC-114A-R2) (230V).....	215
Picture 2-114: Control Circuit 1(SIC-114A-R2) (230V)	217
Picture 2-115: Control Circuit 2(SIC-114A-R2) (230V)	218
Picture 2-116: Control Circuit 3(SIC-114A-R2) (230V)	219
Picture 2-117: Electrical Components Layout 1(SIC-114A-R2) (230V)	221
Picture 2-118: Electrical Components Layout 2(SIC-114A-R2) (230V)	222
Picture 2-119: Thermal Overload Relay	225
Picture 3-1: Installation Location.....	227
Picture 4-1: Control Panel	229
Picture 4-2: Stepup Step 1	231

Picture 4-3: Thermostat	233
Picture 6-1: Fill in the Refrigerant (1).....	240
Picture 6-2: Fill in the Refrigerant (2).....	241

1. General Description



Please read through this operation manual before using and installation to avoid damage of the machine and personal injuries.

SIC-A-R2 series are applicable for cooling molds to reduce products molding cycle, also they are available in the cooling of equipments in order to maintain a normal temperature. Besides, they are suitable for other industries with the need of cooling.



Model: SIC-7.5A-R2

1.1 Coding Principle

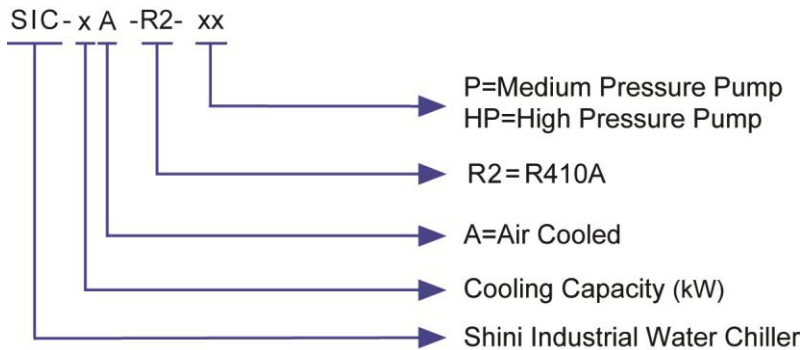

Note *

CE=CE Conformity

1.2 Main Features

1) Standard configuration

- Cooling range 7~25°C.
- Stainless steel made insulated water tank.
- Anti-freezing thermostat.
- Adopt R410A refrigerant.
- Refrigeration loop controlled by high and low pressure switch.
- Compressor and pump overload relays.
- Adopts Italian made temperature controller maintains an accuracy of $\pm 0.1^{\circ}\text{C}$.
- Low pressure pumps are standard configurations.
- All adopt branded compressors with low noise, high efficiency and long service life.

- SIC-A adopts fin style condenser design without any need of cooling water for excellent heat transfer and rapid cooling.

2) Accessory option

- Medium and high pressure pumps are optional to meet any pressure requirements.
- Lever sensor of water tank is available to detect the water level.
- Hot-air bypass valve can be opted to reach the accuracy of $\pm 1^{\circ}\text{C}$.
- Solenoid valve is optional to prevent evaporator freezing by cutting the refrigerant immediately after downtime.
- Level sensor can be opted to detect the refrigerant and ensure its quality and water ratio.
- Optional flow switch to detect chilled water flow.

All service work should be carried out by a person with technical training or corresponding professional experience. The manual contains instructions for both handling and servicing. Chapter 7, which contains service instructions intended for service engineers. Other chapters contain instructions for the daily operator.

Any modifications of the machine must be approved by SHINI in order to avoid personal injury and damage to machine. We shall not be liable for any damage caused by unauthorized change of the machine.

Our company provides excellent after-sales service. Should you have any problem during using the machine, please contact the company or the local vendor.

Headquarter and Taipei factory :

Tel: (886) 2 2680 9119

Shini Plastics Technologies (Dongguan), Inc :

Tel: (86) 769 8111 6600

Shini Plastics Technologies India Pvt.Ltd. :

Tel: (91) 250 3021 166

1.3 Technical Specifications

1.3.1 External Dimensions of SIC-A-R2

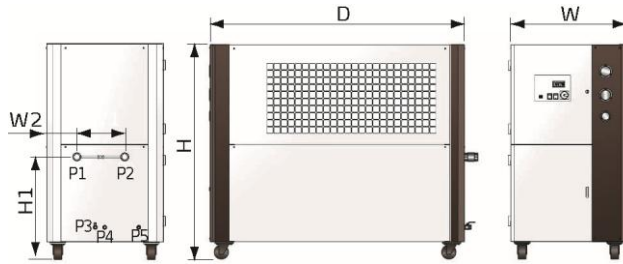

SIC-7.5A-R2~SIC-38A-R2

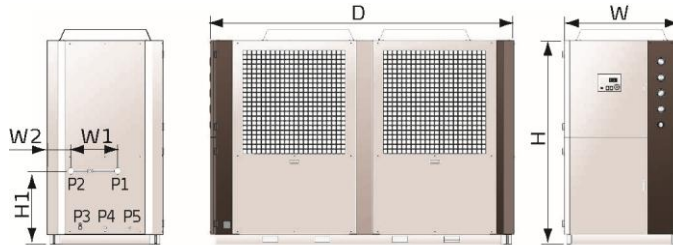

SIC-48A-R2~SIC-75A-R2

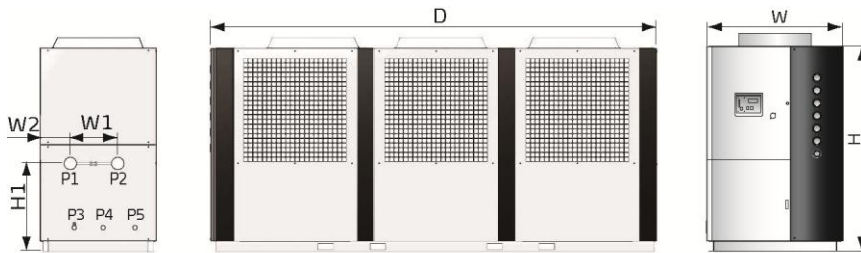

SIC-100A-R2~SIC-114A-R2

Picture 1-1: Outline Dimensional Drawing

Table 1-1: Specifications

Model	H (mm)	H1 (mm)	W (mm)	W1 (mm)	W2 (mm)	D (mm)	P1 Chilled Water Inlet (inch)	P2 Chilled Water Outlet (inch)	P3 Water Tank Outfall (inch)	P4 Water Tank Overfall (inch)	P5 Water Tank Refill Port (inch)	Weight (kg)
SIC-7.5A-R2	1200	625	685	277	200	1190	1	1	1/2	1/2	1/2	305
SIC-12A-R2	1490	640	735	360	174	1320	1	1	1/2	1/2	1/2	315
SIC-18A-R2	1430	640	735	300	204	1610	1½	1½	1/2	1/2	1/2	400
SIC-24A-R2	1440	640	735	300	204	1610	1½	1½	1/2	1/2	1/2	420
SIC-28A-R2	1560	726	905	390	223	1782	1½	1½	1/2	1/2	1/2	530
SIC-38A-R2	1560	726	905	390	223	1782	2	2	1/2	1/2	1/2	540
SIC-48A-R2	1942	755	1208	400	257	2922	2	2	1	1/2	1/2	775
SIC-58A-R2	1942	755	1208	400	257	2922	2	2	1	1/2	1/2	800
SIC-75A-R2	1942	755	1208	418	257	2922	2½	2½	1	1/2	1/2	840
SIC-100A-R2	1942	641	1300	800	243	3475	2½	2½	1	1	1	1400
SIC-114A-R2	1942	641	1300	900	255	3475	2½	2½	1	1	1	1600

1.3.2 Specification List

Table 1-2: Specification List

Item/ Parameters		Model SIC-											
		7.5A-R2	12A-R2	18A-R2	24A-R2	28A-R2	38A-R2	48A-R2	58A-R2	75A-R2	100A-R2	114A-R2	
Refrigerant Capacity ¹⁾	kW (50Hz/60Hz)	7.5 / 8.5	12 / 15.5	18 / 22.5	24 / 30	28 / 35.5	38 / 45	48 / 60	58 / 71	75 / 90	100 / 120	114 / 135	
	kcal/hr (50Hz/60Hz)	6,450 / 7,310	10,320 / 13,072	15,480 / 19,350	20,640 / 25,800	24,080 / 30,530	32,680 / 38,700	41,280 / 51,600	49,880 / 61,060	64,500 / 77,400	86,000 / 103,200	98,040 / 116,100	
Compressor	Type	Scroll											
	Power (50Hz/60Hz)	2.9 / 3.17	4.2 / 5.28	6.5 / 7.8	8.72 / 10.2	9.36 / 11.73	12.25 / 14.8	17.44 / 20.4	18.72 / 23.76	24.86 / 29.6	33.58 / 39.8	37.29 / 44.4	
Refrigerant	Weight (kg)	3.5	5.0	5.5	5.5	9.0	12.5	7.5 × 2	8 × 2	8 × 2	7.8 × 2 + 6.8	8.7 × 3	
	Control Mode	Thermostatic expansion valve											
	Type	R410A											
Evaporator	Type	Tube-in-shell style											
Condenser	Type	Tube-fin style											
	Blower (kW) (50Hz/60Hz)	0.19 / 0.245	0.55 / 0.91	20.23 / 2×0.335	2×0.42 / 2×0.57	2×0.55 / 2×0.91	2×0.8 / 2×1.1	2×1.1 / 2×2.2	2×1.5 / 2×2.2	2×2.2+1.5 / 2×2.2+2.2	3×2.2 / 3×2.2		
Water Tank Capacity (L)		50		85		150		180	200	270	400		
Pump ²⁾ (50Hz/60Hz)	Power (kW)	0.75 / 0.75 / 1.1 / - / 0.75 / 1.5		1.1 / 1.1 / 1.1 / - / 1.1 / 1.1		1.1 / 1.5 / 2.2 / - / 2.2 / 2.2		2.2 / 3.0 / 4.0 / - / 3.0 / 3.0		4.0 / 3.0 / 4.0 / - / 5.5 / 5.5		4.0 / 4.0 / 5.5 / - / 5.5 / 5.5	
	Pump Flow (L/min)	50 / 83 / 67 / - / 83 / 67		80 / 100 / 89 / - / 100 / 89		130 / 150 / 133 / - / 150 / 133		200 / 300 / 400 / 200 / 300 / 400		200 / 300 / 400 / 200 / 300 / 400		533 / 366 / 367 / 533 / 366 / 367	
	Working Pressure (kg/cm ²)	2.0 / 2.6 / 3.8 / - / 2.6 / 3.8		2.0 / 2.6 / 3.5 / - / 2.6 / 3.5		2.0 / 3.0 / 4.2 / - / 3.0 / 4.2		2.5 / 3.0 / 4.2 / 2.5 / 3.0 / 4.2		2.5 / 3.0 / 4.2 / 2.5 / 3.0 / 4.2		2.7 / 3.4 / 4.3 / 2.7 / 3.4 / 4.3	
Total Power (kW) (50Hz/60Hz)		3.85 / 3.9	5.5 / 5.86	7.5 / 8.47	10.66 / 12.44	11.66 / 15.74	15 / 19.2	21.84 / 27.8	23.12 / 30.86	31.86 / 39.5	43.48 / 51.9	47.89 / 53.51	
Pipe Coupling (inch)	Cooling Water Outlet (50Hz/60Hz)	1 / 1		1½ / 1½			2 / 2			2.5 / 2.5			
	Water Tank Inlet (50Hz/60Hz)	1 / 1		1½ / 1½			2 / 2			2.5 / 2.5			
	Water Tank Inlet	1/2						1					
	Water Tank Overflow	1/2						1					
Protective Devices	Compressor	Overload relay											
	Pump	Overload relay											
	Cooling Water Circuit	High and low pressure switch/anti-freeze switch											
	Water Circuit	Water level switch (Optional)/By-pass valve											
Operation Noise dB (A)		78	75	74	78	81	86	84	82	86	90	90	
Power(VAC)		3Φ, 400VAC, 50Hz											
Measures Exchange		1 kW = 860 kcal/hr			1 RT = 3,024 kcal/hr			10,000 Btu/hr = 2,520 kcal/hr					

Note:

- 1) Refrigeration capacity is measured based on the flow 0.172 m³ / (h.k W) and the outlet temperature (7°C) of chilled water under the environment temperature of 35°C.
- 2) Low pressure pump is for domestic and Southeast Asia export, customers can change for medium pressure pumps (use P for short; e.g.: SIC-and A-R2-P) or high pressure pumps (use HP for short; e.g.: SIC-and A-R2-HP), specific parameters in turn as shown above.
- 3) Pump power is included in total power.
- 4) Special orders of machine voltage can be acceptable according to customers' requests.
- 5) The air-cooled water chiller is applicable to the conditions under the environment temperature of 43°C.

1.4 Safety Regulations

The user must conform to the following safety rules when operating the machine.

1.4.1 Security Labels



Attention!

Installation of the device is allowed only to the professional electrician.
Before maintaining and repairing the device, be sure to turn off the main switch and control switch.



Warning! High Voltage!

This label is posted on enclosure of the electrical control cabinet!



Warning! Be careful!

Pay more attentions at the places where this sign is attached!



Attention!





Drain the water inside when power off at the cold day to avoid freezing!



Attention!

No need for regular inspection because all the electrical parts in the control unit are fixed tightly!

1.4.2 Signs and Labels

	<p>This is for indicating motor rotating direction. When phase reversal happens, the alarm sounds and indicator on control panel will indicate. Please exchange the place of the two electrical wires to solve this problem.</p>
	<p>Pump pressure gauge: display actual pressure of cold water system.</p>
	<p>High pressure gauge: display pressure in the high-pressure side of refrigerant system.</p>
	<p>Low pressure gauge: display pressure in the low-pressure side of refrigerant system.</p>

1.5 Exemption Clause

The following statements clarify the responsibilities and regulations born by any buyer or user who purchases products and accessories from Shini (including employees and agents).

Shini is exempted from liability for any costs, fees, claims and losses caused by reasons below:

1. Any careless or man-made installations, operation and maintenances upon machines without referring to the Manual prior to machine using.
2. Any incidents beyond human reasonable controls, which include man-made vicious or deliberate damages or abnormal power, and machine faults caused by irresistible natural disasters including fire, flood, storm and earthquake.
3. Any operational actions that are not authorized by Shini upon machine, including adding or replacing accessories, dismantling, delivering or repairing.
4. Employing consumables or oil media that are not appointed by Shini.

2. Structural Features and Working Principle

2.1 Main Functions

SIC-A-R2 series are applicable for cooling molds to reduce products molding cycle, also they are available in the cooling of equipments in order to maintain a normal temperature. Besides, they are suitable for other industries with the need of cooling.

2.1.1 Working Principle

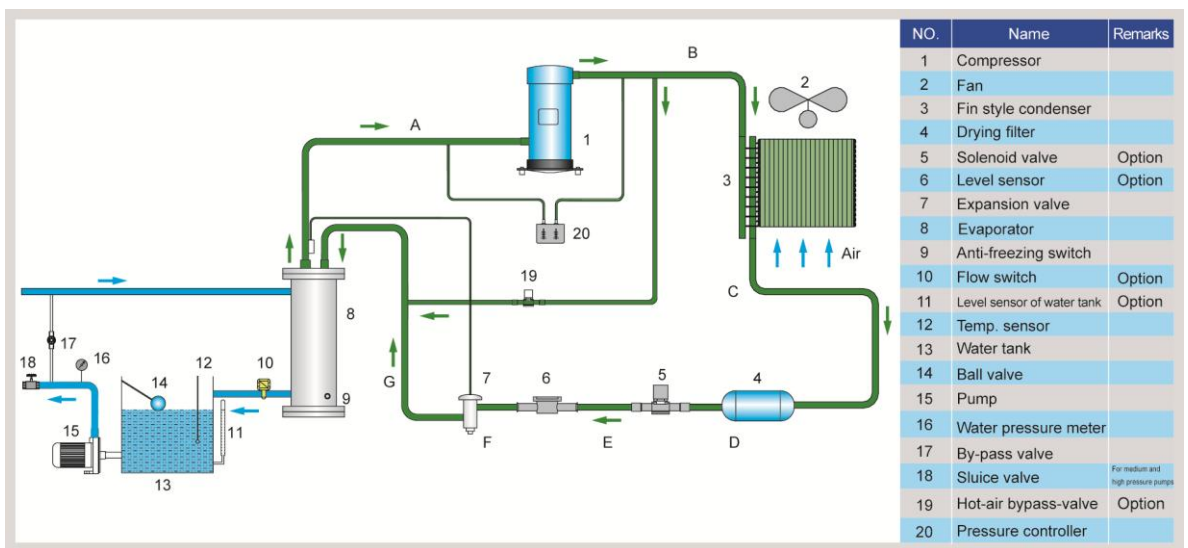

Picture 2-1: Working Principle Diagram

When the SIC-A-R2 air-cooled water chiller starting up, compressor starts working. Refrigerant is compressed into high temperature high pressure gas in the process from B to C, and then be cooled when passing through the condenser and changed into liquid. Heat is taken away by the cooling air. In the process from C to D to E and F, the liquid refrigerant is dried and filtered by the dry filter. After that, it passes through the solenoid valve, level sensor and then reaches the expansion valve. In the process from F to G, the high pressure liquid refrigerant is throttled and depressurized by the heat expansion valve and the temperature goes down. In the process of G to A, chilled water absorbs the heat of process water in the evaporator and returns back to the compressor. This heat exchange process repeats until process water is cooled down to required temperature.

Hot-air bypass function: the compressor continues working when the process water is cooled down to the required temperature, then the hot-air bypass valve opens as the temperature drops to its set value. A part of the refrigerant from the compressor passes through the bypass valve and then reach the evaporator, balancing out part of the machine refrigerating capacity and then goes back to the compressor without passing through the condenser. With the help of hot-air bypass valve, the system can stay in an balanced condition and meanwhile can keep the control accuracy at $\pm 1^{\circ}\text{C}$.

2.2 Parts Drawing

2.2.1 Structure Chart (SIC-7.5A-R2)

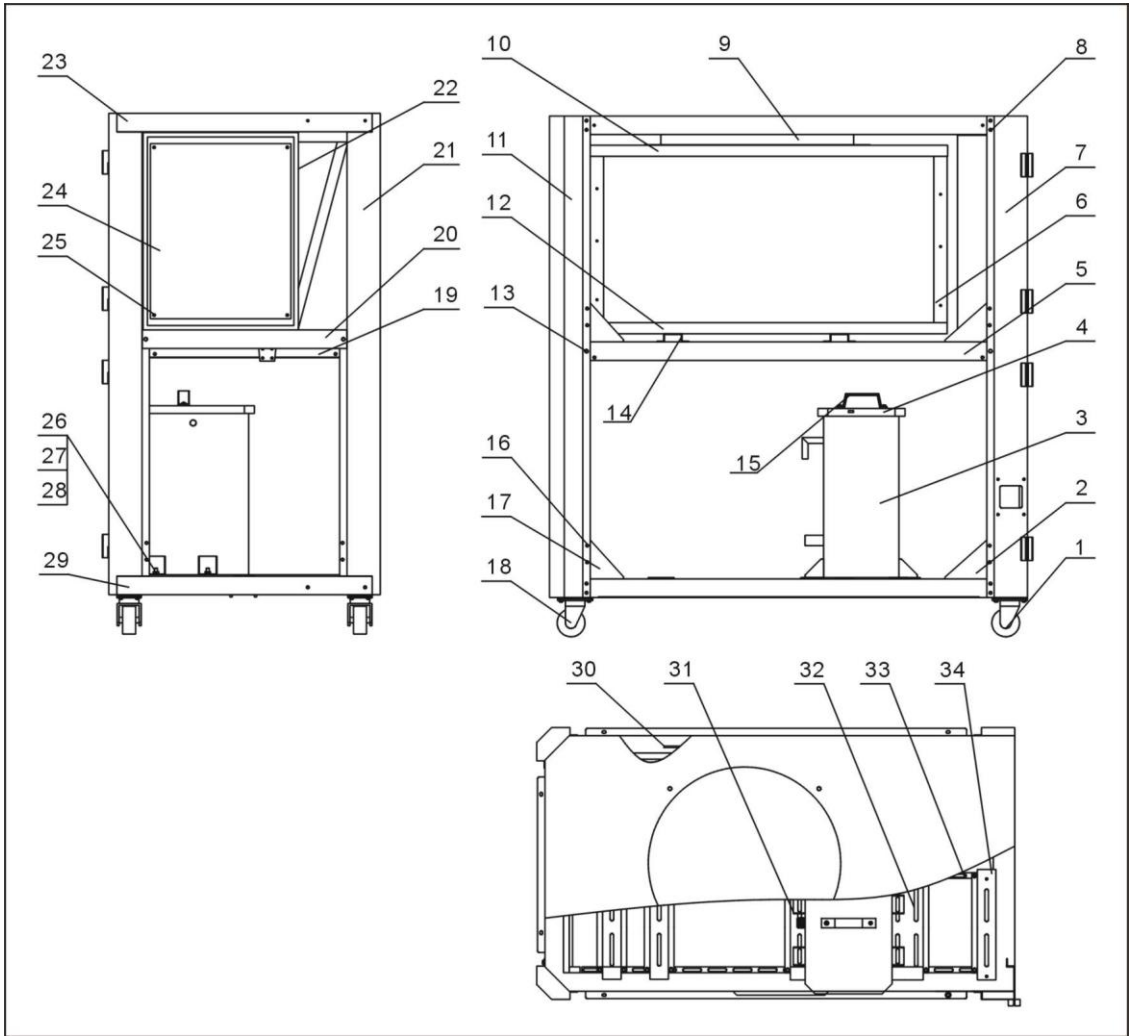

Note: For details of the numbers in the parts drawing, please refer to the part list in 2.2.2

Picture 2-2: Structure Chart (SIC-7.5A-R2)

2.2.2 Structure Chart Parts List (SIC-7.5A-R2)

Table 2-1: Structure Chart Parts List (SIC-7.5A-R2)

No.	Name	Parts No.	No.	Name	Parts No.
1	Braking black castor 3"	YW03000300000	18	Movable black castor 3"PP	YW03000300200
2	Triangle support (left)	-	19	Middle back beam	-
3	Water tank	-	20	Electric control cabinet support	-
4	Water tank Cover	-	21	Right front stand stand column	-
5	Left part of middle beam	-	22	Electric control cabinet	-
6	Fan cover 1	-	23	Top plate	-
7	Left front stand stand column	-	24	Base plate of electric control cabinet	-
8	Hexbolt M6×20	YW60062000100	25	Screw M6×20	YW62062000000
9	Fan guide	-	26	Hexnut M8	YW64080600000
10	Fan cover 3	-	27	Spring washer 8	YW65008000100
11	Back stand stand column	-	28	Flat washer 8	YW66082200100
12	Fan cover 2	-	29	Base frame	-
13	Hexbolt M8×20	YW60082000300	30	Right part of middle beam	-
14	Condensor support	-	31	Lower beam 1	-
15	Square handle	BW20012000040	32	Lower beam 2	-
16	Screw M6×10	YW62061000000	33	Middle lower beam	-
17	Triangle support (right)	-	34	Lower beam 3	-

* means possible broken parts. ** means easy broken parts. Spare backup is suggested. Please confirm the version number of the manual before you order to ensure the stock number and the parts are consistent.

2.2.3 Water System Diagram (SIC-7.5A-R2)

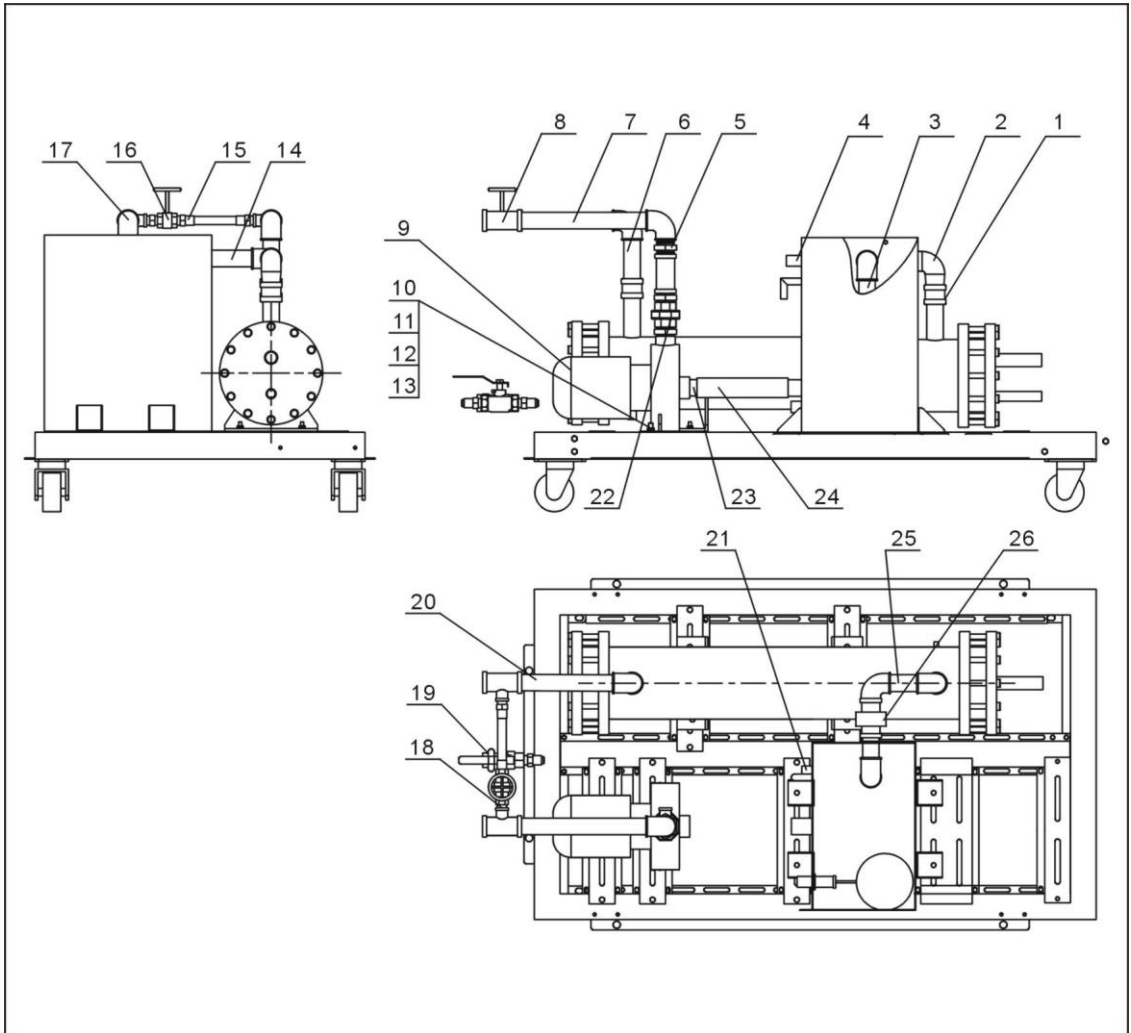

Note: For details of the numbers in the parts drawing, please refer to the part list in 2.2.4

Picture 2-3: Water System Diagram (SIC-7.5A-R2)

2.2.4 Water System Parts List (SIC-7.5A-R2)

Table 2-2: Water System Parts List (SIC-7.5A-R2)

No.	Name	Parts No.	No.	Name	Parts No.
1	Direct connection1"	YW51000100000	14	Galvanized steel pipe 4	-
2	Street elbow 1"	YW53100100000	15	Copper inserted core 1/2"	BH12161200010
3	Galvanized steel pipe 1	-	16	Sluice valve 1/2"	YW50010200000
4	Floating ball valve 1/2"	YW59010200000	17	Pipe elbow 1"	YW53100000000
5	Inner joint 1"	YW50000100000	18	Copper pipe coupler 1/2" × 1/2"	BH12010200010
6	Galvanized steel pipe 2	-	19	Copper cored ball valve 1/2"	YW50010200100
7	Galvanized steel pipe 3	-	20	Galvanized steel pipe5	-
8	T connection1" × 1/2"	YW52101200100	21	T connection1/2"	YW52100200000
9	Water pump	-	22	Loosen joint 1"	YW54000100000
10	Hexnut M8	YW64080600000	23	Galvanized steel pipe 6	-
11	Spring washer 8	YW65008000100	24	Black rubber hose	YR60320500000
12	Flat washer 8	YW66082200100	25	Galvanized steel pipe 7	-
13	Hexnut M8×20	YW60082000300	26	Flow switch 1"	YW85005000000

* means possible broken parts. ** means easy broken parts. Spare backup is suggested. Please confirm the version number of the manual before you order to ensure the stock number and the parts are consistent.

2.2.5 Refrigerant System Diagram (SIC-7.5A-R2)

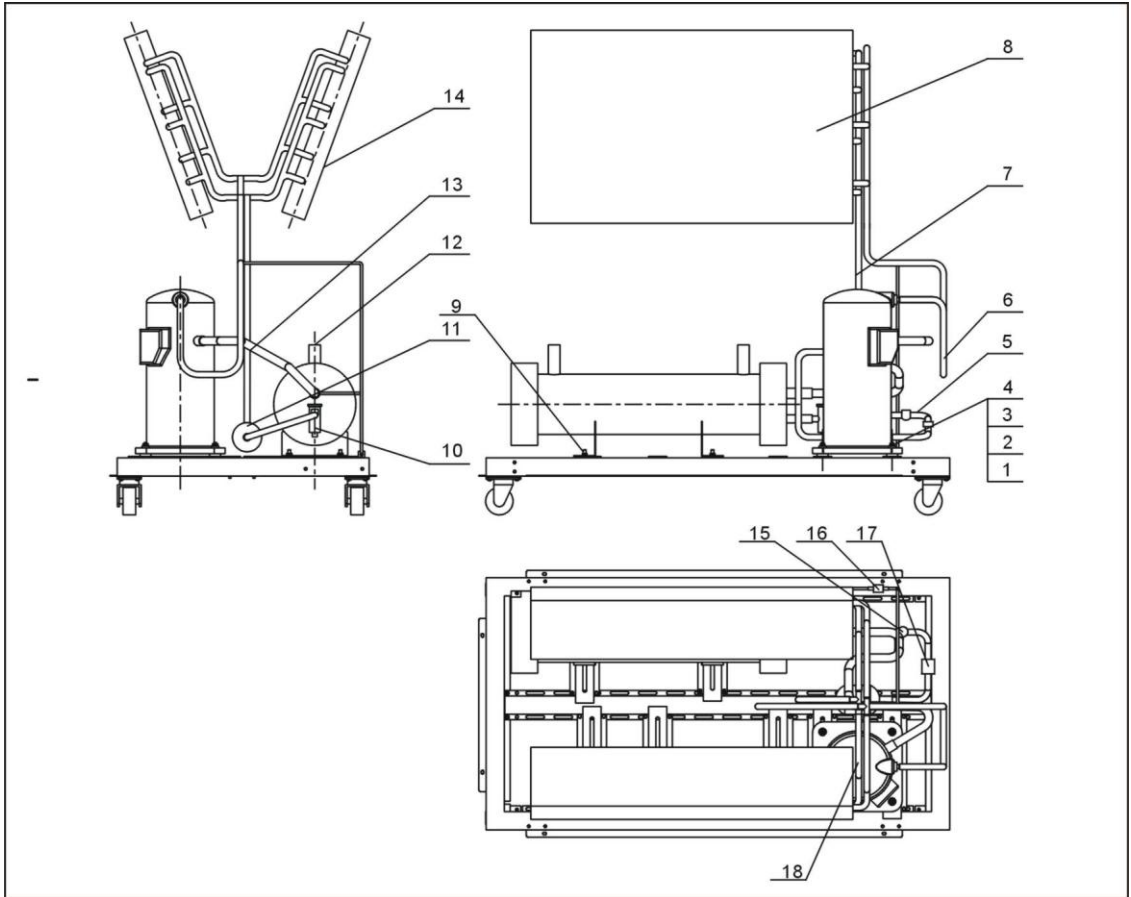

Note: For details of the numbers in the parts drawing, please refer to the part list in 2.2.6

Picture 2-4: Refrigerant System Diagram (SIC-7.5A-R2)

2.2.6 Refrigerant System Parts List (SIC-7.5A-R2)

Table 2-3: Refrigerant System Parts List (SIC-7.5A-R2)

No.	Name	Parts No.	No.	Name	Parts No.
1	Hexbolt M8×50	YW60085000000	10	thermostatic expansion valve	-
2	Flat washer 8	YW66082200100	11	Drying filter EK-053S	YW85016530100
3	Spring washer8	YW65008000100	12	Evaporator	-
4	Hexnut M8	YW64080600000	13	Air suction pipe	-
5	Liquid pipe 2	-	14	Right condenser	-
6	Exhaust pipe	-	15	Refrigerant indicator HMI-1TT3	YW85001300100
7	Liquid pipe 1	-	16	By-pass valve	YE32008300000
8	Left condensor	-	17	Solenoid valve	-
9	Hexbolt M8×20	YW60082000300	18	compressor	-

* means possible broken parts. ** means easy broken parts. Spare backup is suggested. Please confirm the version number of the manual before you order to ensure the stock number and the parts are consistent.

2.2.7 General Assembly Diagram (SIC-7.5A-R2)

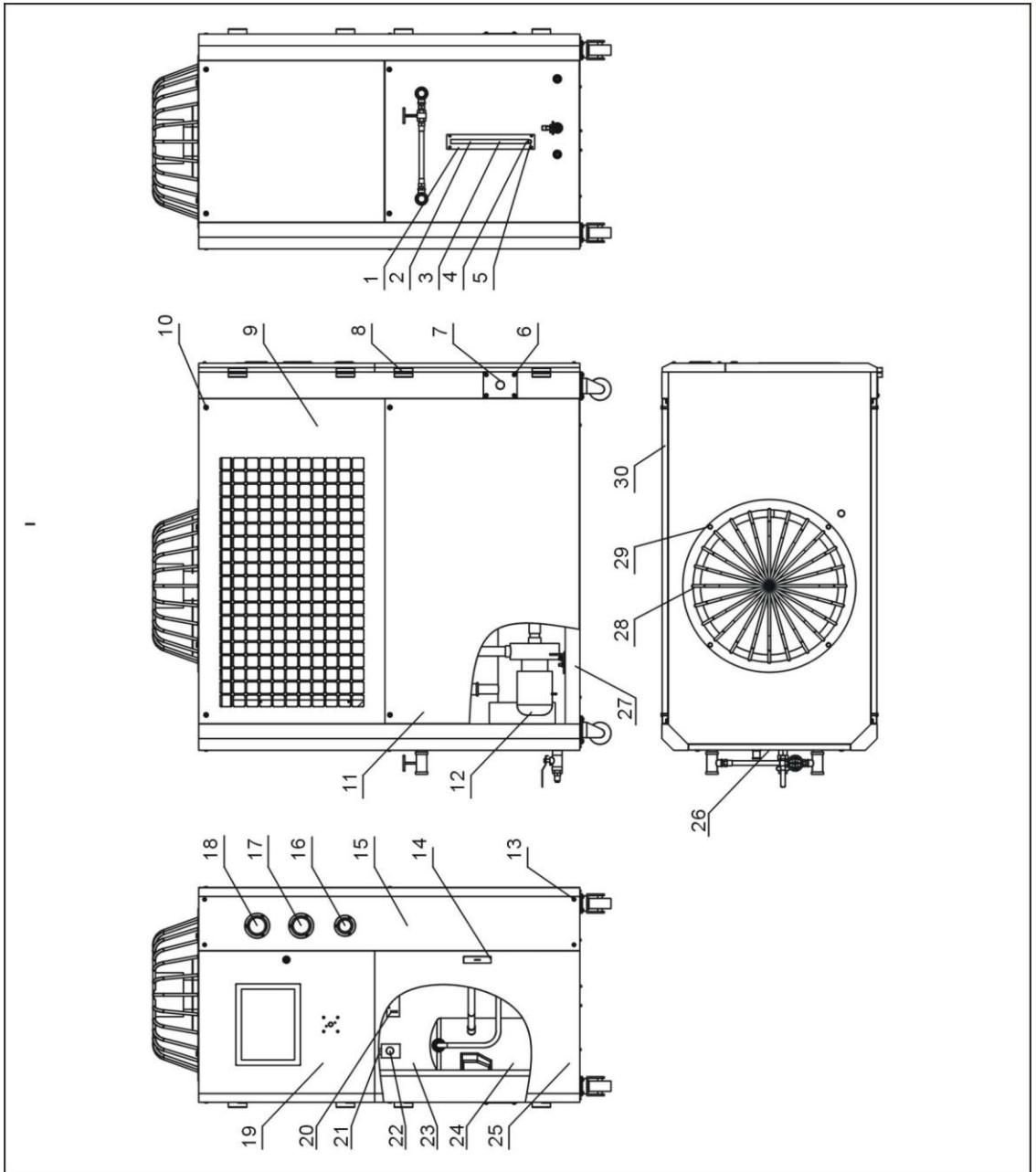

Note: For details of the numbers in the parts drawing, please refer to the part list in 2.2.8

Picture 2-5: General Assembly Diagram (SIC-7.5A-R2)

2.2.8 General Assembly Parts List (SIC-7.5A-R2)

Table 2-4: General Assembly Parts List (SIC-7.5A-R2)

No.	Name	Parts No.	No.	Name	Parts No.
1	Liquid level indicator cover	BL90006800020	16	Water pressure guage	YW85001000100
2	Glass tube	YW70963000000	17	Low pressure guage	YW85003500000
3	Liquid level indicator STM-310	BH12030000010	18	High pressure guage	YW85005500000
4	Level indicator screw	BH12060700110	19	Upper door	-
5	Level indicator base	YW20000000400	20	Pressure controller	YE90124500000
6	Screw M6×10	YW62061000000	21	Fixing block of anti-freezing switch	-
7	Line jig fixed plate	-	22	Adjustable anti-freezing switch	YW85071100000
8	Hinge	YW06203100400	23	Rear plate 1	-
9	Side plate 2 (left)	-	24	Refrigerant system	-
10	Screw M6×30	YW62063000000	25	Lower door	-
11	Side plate 1	-	26	Rear plate 2	-
12	Water system	-	27	Rack	-
13	Screw M6×45	YW63064500000	28	Fan	-
14	Door lock	YW00717100000	29	Hexbolt M8×20	YW60082000300
15	Gauge plate	-	30	Side plate 2 (right)	-

* means possible broken parts. ** means easy broken parts. Spare backup is suggested. Please confirm the version number of the manual before you order to ensure the stock number and the parts are consistent.

2.2.9 Racking Diagram (SIC-12A-R2)

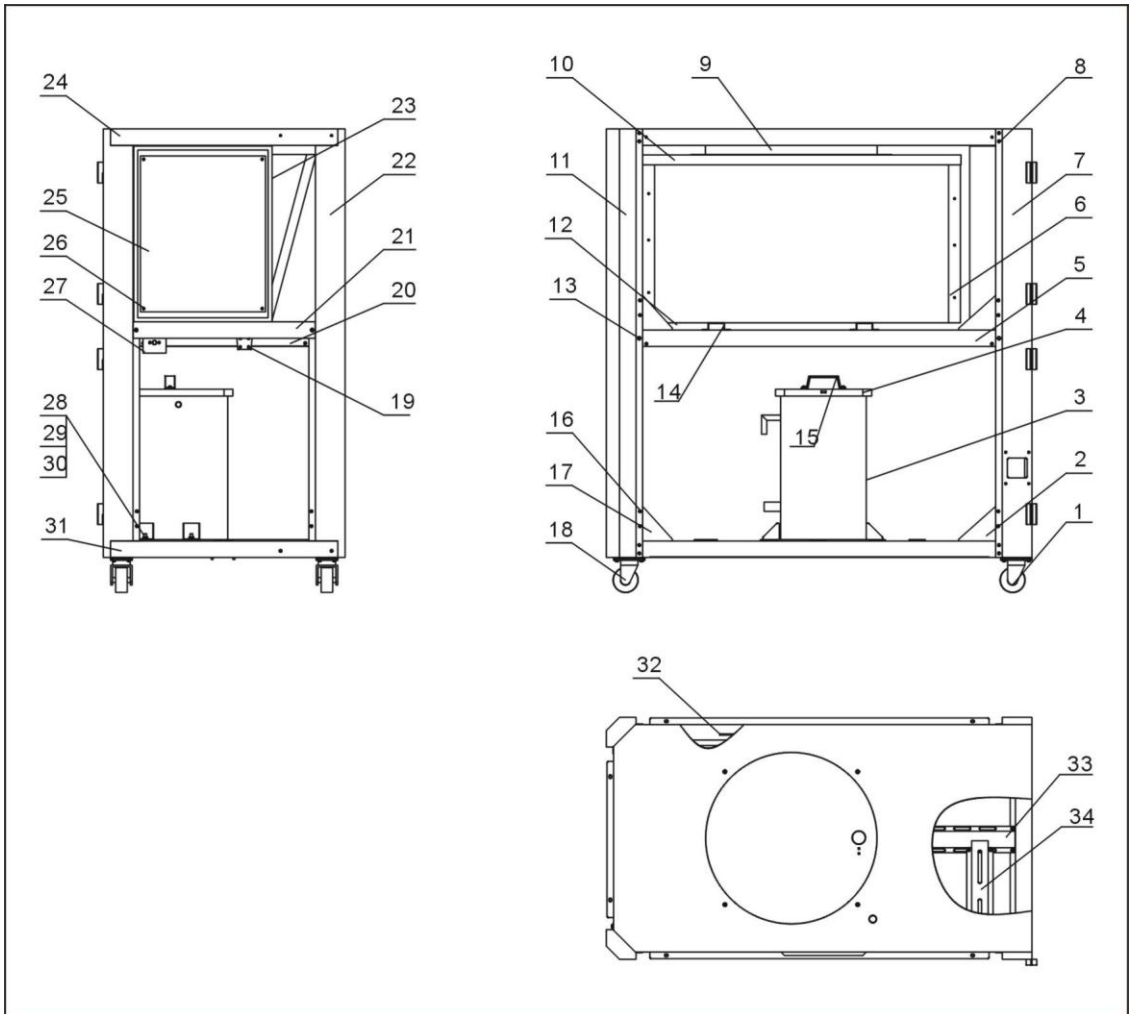

Note: For details of the numbers in the parts drawing, please refer to the part list in 2.2.10

Picture 2-6: Rack Diagram (SIC-12A-R2)

2.2.10 Rack Parts List (SIC-12A-R2)

Table 2-5: Rack Parts List (SIC-12A-R2)

No.	Name	Parts No.	No.	Name	Parts No.
1	Braking black castor 3"	YW03000300000	18	Movable black castor 3"	YW03000300200
2	Triangle support	-	19	Fixed block of pressure switch	BL21000603020
3	Water tank	-	20	Middle back beam	-
4	Water tank cover	-	21	Electric control cabinet support	-
5	Left part of middle beam	-	22	Right front stand stand column	-
6	Fan cover 3	-	23	Electric control cabinet	-
7	Left front stand stand column	-	24	Top plate	-
8	Hexbolt M6×20	YW60062000100	25	Base of electric control cabinet	-
9	Fan guide	-	26	Screw M6×20	YW62062000000
10	Fan cover 1	-	27	Fixed plate of anti-freezing switch	-
11	Back stand stand column	-	28	Hexnut M8	YW64080600000
12	Fan cover 2	-	29	Spring washer 8	YW65008000100
13	Hexbolt M8×20	YW60082000300	30	Flat washer 8	YW66082200100
14	Condensor support	-	31	Base frame	-
15	Square handle	BW20012000040	32	Right part of middle beam	-
16	Screw M6×10	YW62061000000	33	Middle lower beam	-
17	Triangle support 2	-	34	Lower beam	-

* means possible broken parts. ** means easy broken parts. Spare backup is suggested. Please confirm the version number of the manual before you order to ensure the stock number and the parts are consistent.

2.2.11 Water System Diagram (SIC-12A-R2)

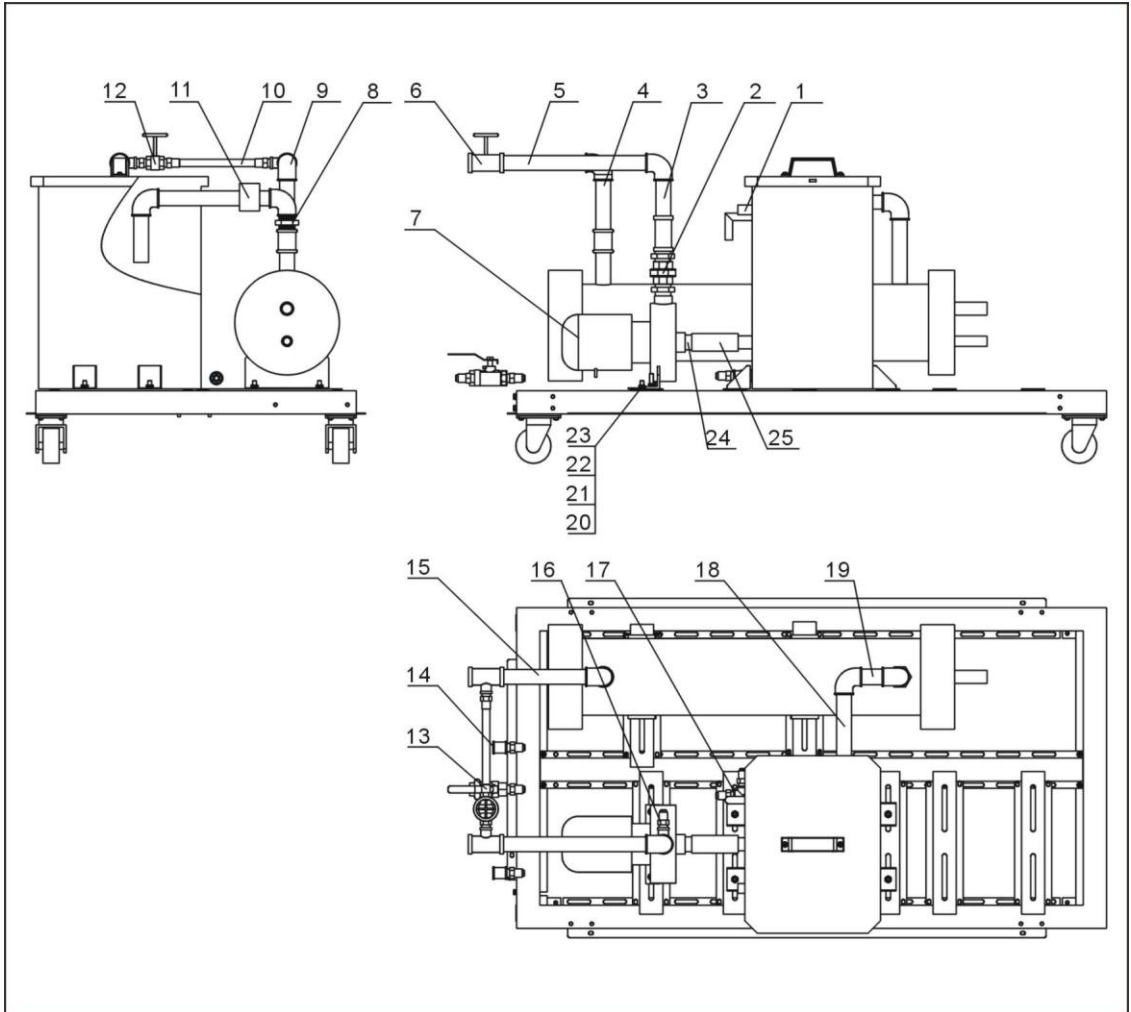

Note: For details of the numbers in the parts drawing, please refer to the part list in 2.2.12

Picture 2-7: Water System Diagram (SIC-12A-R2)

2.2.12 Water System Parts List (SIC-12A-R2)

Table 2-6: Water System Parts List (SIC-12A-R2)

No.	Name	Parts No.	No.	Name	Parts No.
1	Floating ball valve 1/2"	YW59010200000	14	Direct connection 1/2"	YW51001200000
2	Loosen joint 1"	YW54000100000	15	Galvanized steel pipe 4	-
3	Galvanized steel pipe 6	-	16	Copper ferrule 1/2"	BH12161200010
4	Galvanized steel pipe 3	-	17	T-connection 1/2"	YW52100200000
5	Galvanized steel pipe 5	-	18	Galvanized steel pipe 1	-
6	T-connection 1" x 1/2"	YW52101200100	19	Galvanized steel pipe 7	-
7	Water pump	-	20	Hexnut M8x20	YW60082000300
8	Inner joint 1"	YW50000100000	21	Flat washer 8	YW66082200100
9	Bent 1"	YW53100000000	22	Spring washer 8	YW65008000100
10	Copper pipe 1	-	23	Hexnut M8	YW64080600000
11	Flow switch 1"	YW85005000000	24	Galvanized steel pipe 2	-
12	Sluice valve 1/2"	YW50010200000	25	Blace rubber hose	YR60320500000
13	Ball valve 1/2"	YW50010200100			

* means possible broken parts. ** means easy broken parts. Spare backup is suggested. Please confirm the version number of the manual before you order to ensure the stock number and the parts are consistent.

2.2.13 Refrigerant System Diagram (SIC-12A-R2)

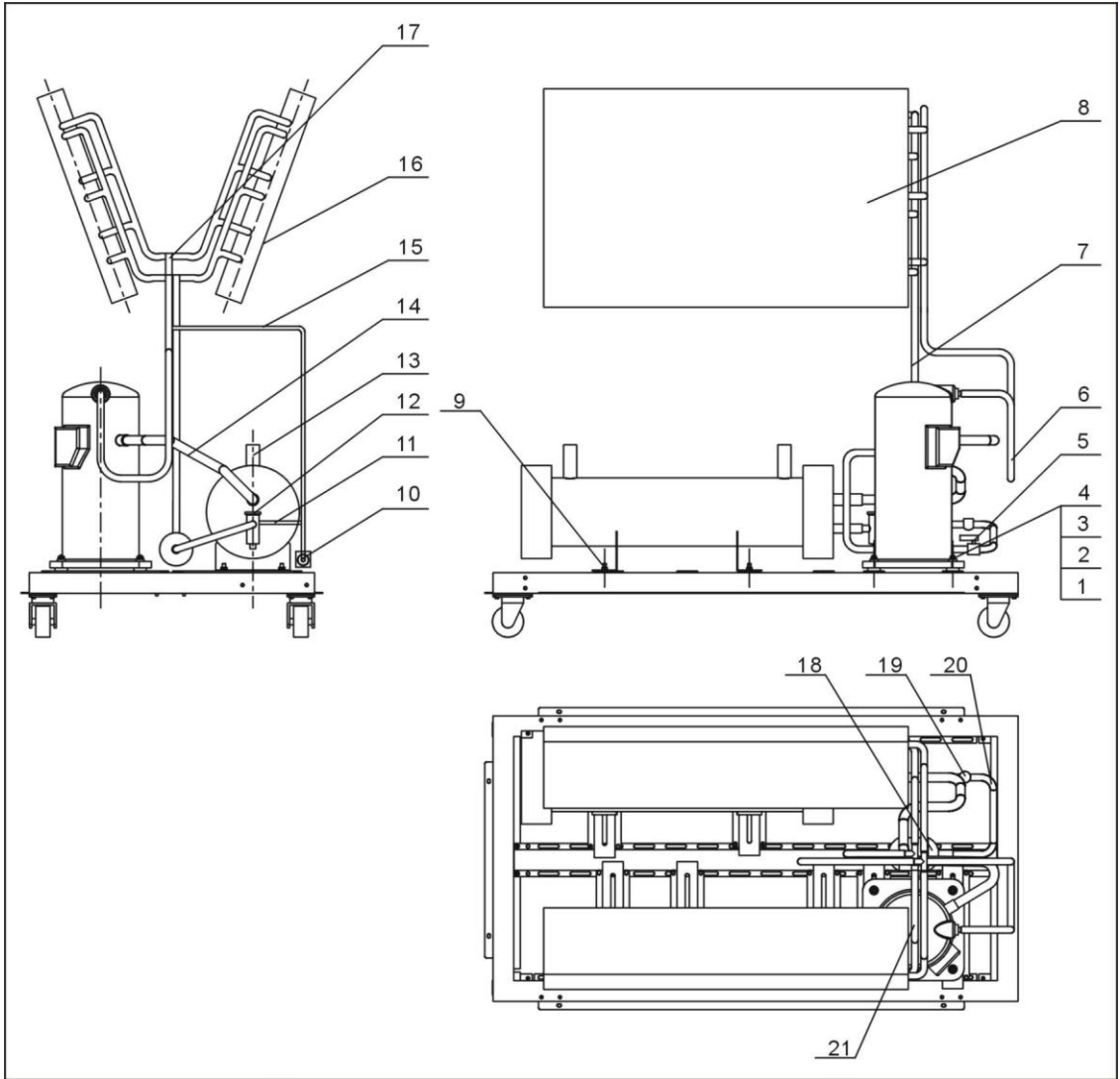

Note: For details of the numbers in the parts drawing, please refer to the part list in 2.2.14

Picture 2-8: Refrigerant System Diagram (SIC-12A-R2)

2.2.14 Refrigerant System Parts List (SIC-12A-R2)

Table 2-7: Refrigerant System Parts List (SIC-12A-R2)

No.	Name	Parts No.	No.	Name	Parts No.
1	Hexbolt M8×50	YW60085000000	12	Thermostate expansion valve	-
2	Flat washer 8	YW66082200100	13	Evaporator	-
3	Spring washer 8	YW65008000100	14	Air suction pipe	-
4	Hexnut M8	YW64080600000	15	Copper pipe 2	
5	Solenoid valve	-	16	Right condenser	-
6	Exhaust pipe 1	-	17	Exhaust pipe 2	-
7	Liquid pipe 1	-	18	Drying filter EK-053S	YW85016530100
8	Left condenser	-	19	Refrigerant indicator HMI-1TT3	YW85001300100
9	Hexbolt M8×20	YW60082000300	20	Liquid pipe 2	-
10	By-pass valve	YE32008300000	21	Compressor	-
11	Copper pipe 3	-			

* means possible broken parts. ** means easy broken parts. Spare backup is suggested. Please confirm the version number of the manual before you order to ensure the stock number and the parts are consistent.

2.2.15 Rack Diagram (SIC-12A-R2)

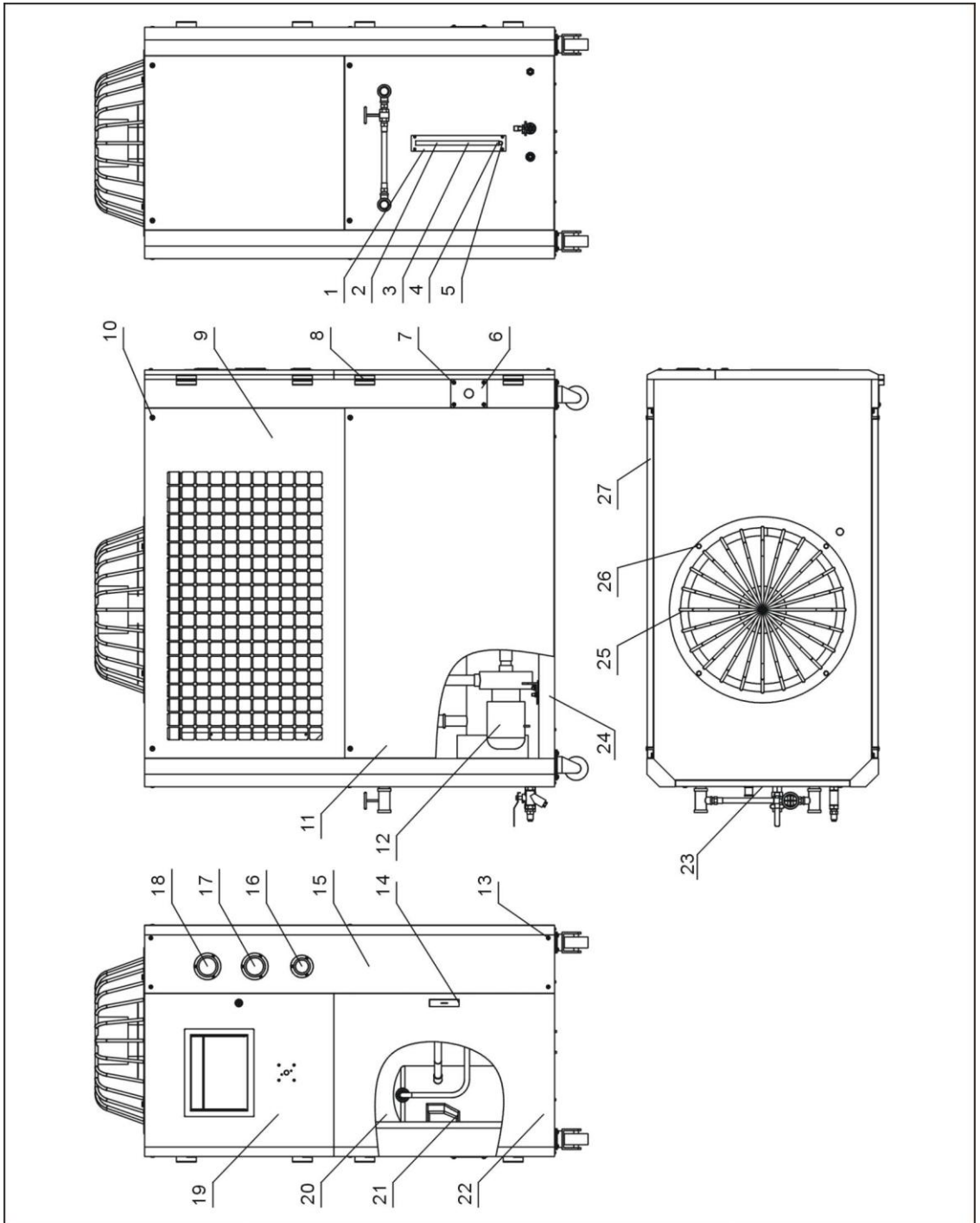

Note: For details of the numbers in the parts drawing, please refer to the part list in 2.2.16

Picture 2-9: Rack Diagram (SIC-12A-R2)

2.2.16 Rack Parts List (SIC-12A-R2)

Table 2-8: Rack Parts List (SIC-12A-R2)

No.	Name	Parts No.	No.	Name	Parts No.
1	Refrigerant indicator cover	BL90006800020	16	Water pressure gauge	YW85001000100
2	Galss tube	YW70963000000	17	Low pressure gauge	YW85601800000
3	Refrigerant indicator STM-310	BH12030000010	18	High pressure gauge	YW85603800000
4	Indicator screw	BH12060700110	19	Upper door	-
5	Indicator base	YW20000000400	20	Rear plate 1	-
6	Screw M6×10	YW62061000000	21	Refrigerant system	-
7	Line jig fixed plate	-	22	Lower door	-
8	Hinge	YW06203100400	23	Rear palte 2	-
9	Side plate 1	-	24	Rack	-
10	Screw M6×30	YW62063000000	25	Fan	-
11	Side plate 3	-	26	Hexbolt M8×20	YW60082000300
12	Water system	-	27	Side plate 2	-
13	Screw M6×45	YW63064500000	28		
14	Door lock	YW00717100000	29		
15	Gauge plate	-	30		

* means possible broken parts. ** means easy broken parts. Spare backup is suggested. Please confirm the version number of the manual before you order to ensure the stock number and the parts are consistent.

2.2.17 Rack Diagram (SIC-18A-R2~24A-R2)

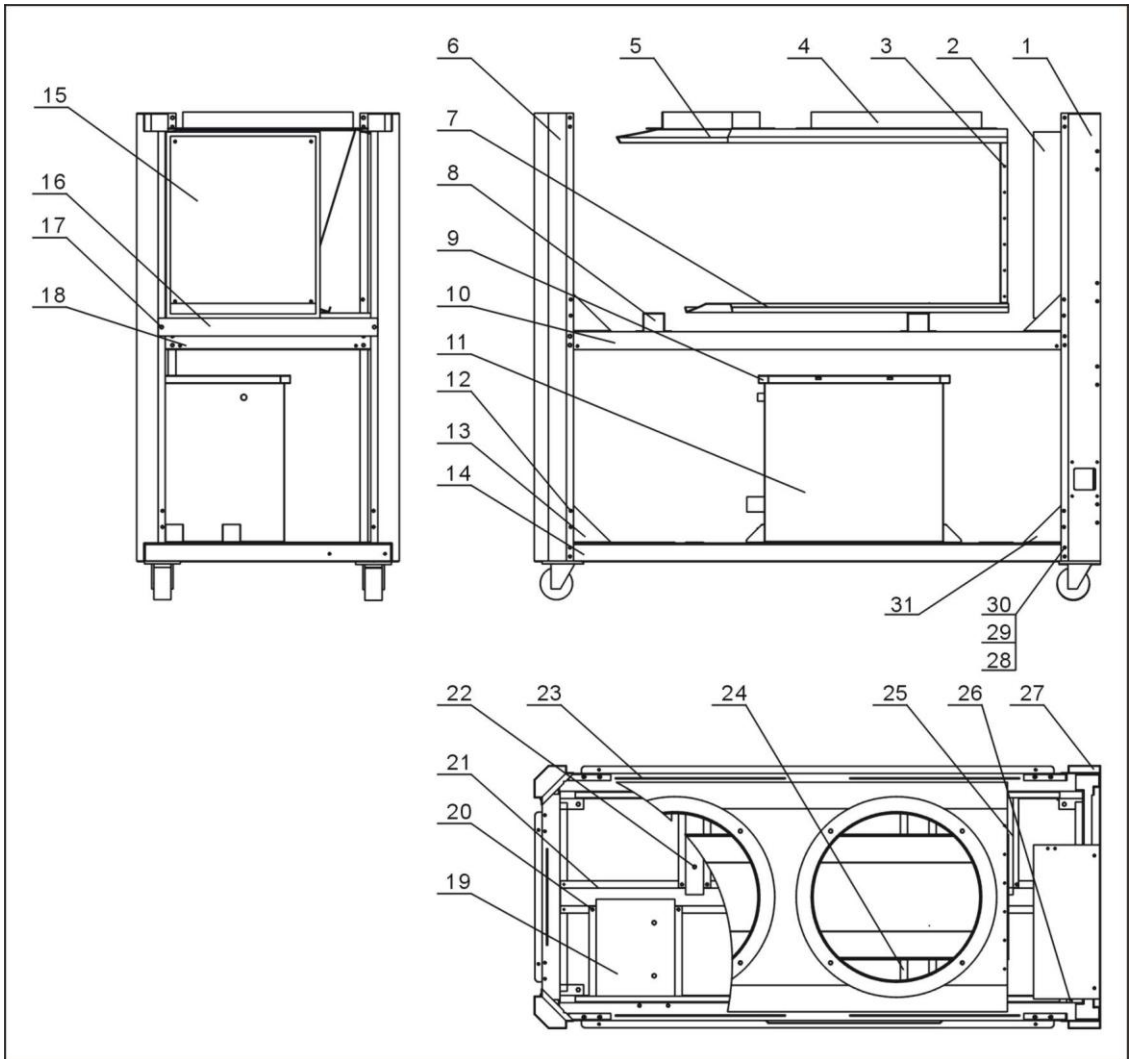

Note: For details of the numbers in the parts drawing, please refer to the part list in 2.2.18

Picture 2-10: Rack Diagram (SIC-18A-R2~24A-R2)

2.2.18 Rack Parts List (SIC-18A-R2~24A-R2)

Table 2-9: Rack Parts List (SIC-18A-R2~24A-R2)

No.	Name	Parts No.	No.	Name	Parts No.
1	Left front stand stand column	-	17	Hexbolt M8×20	YW60082000500
2	Electric control cabinet	-	18	Back beam	-
3	Baffle palte of condensor	-	19	Pump angle iron	-
4	Fan guide	-	20	Screw M6	-
5	Condenser cover	-	21	Lower middle beam	-
6	Back stand stand column	-	22	Condensor angle iron	-
7	Condenser base	-	23	Right beam	-
8	Condensor supporting	-	24	Water tank angle iron	-
9	Water tank cover	-	25	Solenoid valve angel iron	-
10	Left beam	-	26	Compressor angle iron	-
11	Water tank	-	27	Right front stand stand column	-
12	Triangle supporting (right)	-	28	Hexbolt M6×20	YW60062000100
13	Screw M6×20	YW63062000000	29	Spring washer 6	YW65006000100
14	Base frame	-	30	Falt washer 6	YW66061300000
15	Rear plate of electric control cabinet	-	31	Triangle supporting (left)	-
16	Middle beam	-			-

* means possible broken parts. ** means easy broken parts. Spare backup is suggested. Please confirm the version number of the manual before you order to ensure the stock number and the parts are consistent.

2.2.19 Water System Diagram (SIC-18A-R2~24A-R2)

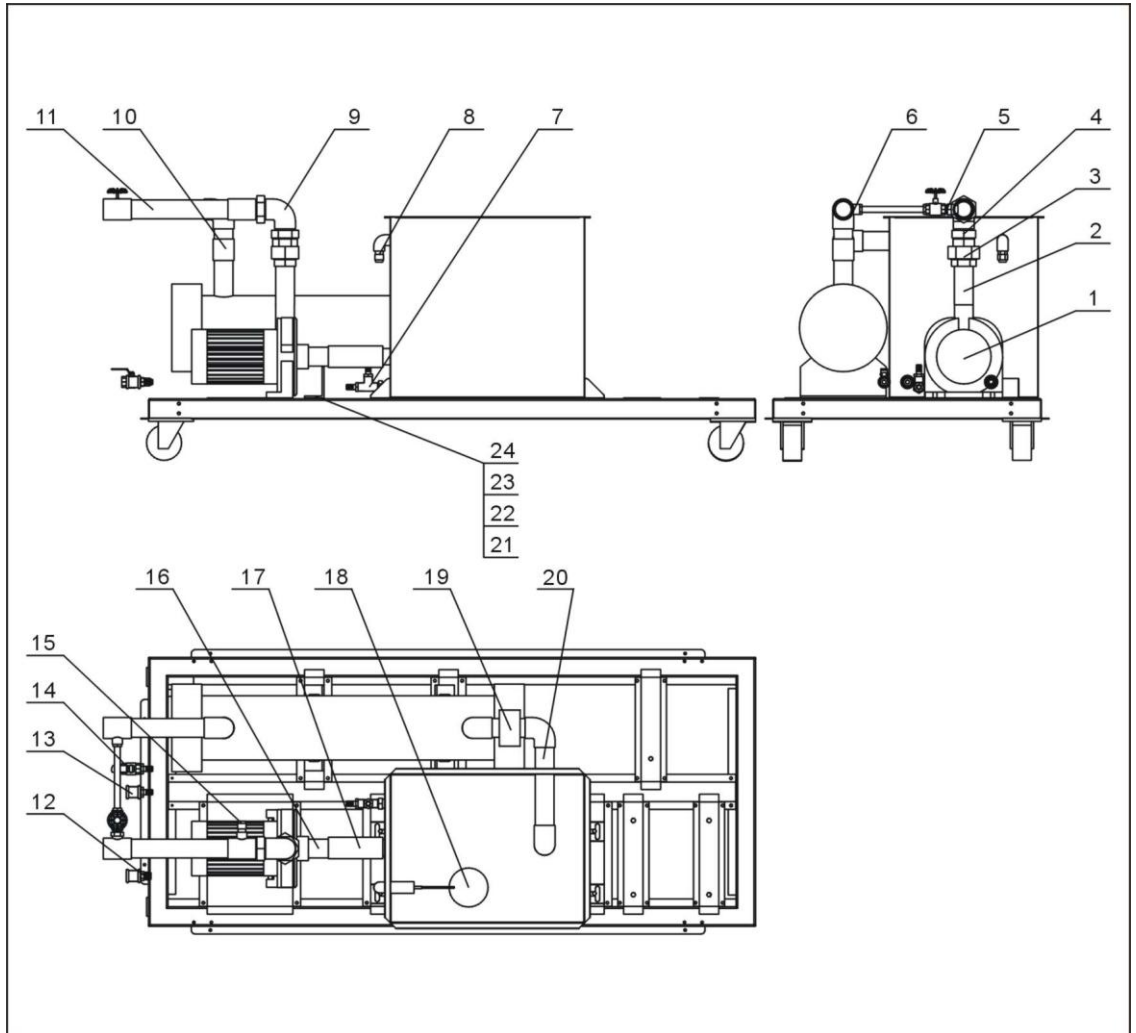

Note: For details of the numbers in the parts drawing, please refer to the part list in 2.2.20

Picture 2-11: Water System Diagram (SIC-18A-R2~24A-R2)

2.2.20 Water System Parts List (SIC-18A-R2~24A-R2)

Table 2-10: Water System Parts List (SIC-18A-R2~24A-R2)

No.	Name	Parts No.	No.	Name	Parts No.
1	Water pump	-	13	Direct connection 1/2"	YW51001200000
2	Galvanized steel pipe 1	-	14	Copper cored valve 1/2"	YW50010200100
3	Loosen joint 1-1/2"	YW54001500000	15	Copper joint 1/2"PT x1/4"H	BH12010400610
4	Loosen joint 1-1/2"	YW50001500100	16	Galvanized steel pipe 4	-
5	Copper pipe coupler 1/2"	BH12010200010	17	Blake rubber hose	YR60480500000
6	T-connection 1-1/2" x1/2"	YW52151200100	18	Floating ball valve 1/2"	YW59010200000
7	T-connection 1/2"	YW52100200000	19	Flow switch 1"	YW85005000000
8	Teflon joint 1/2"	BH12010200210	20	Galvanized steel pipe 3	-
9	Bent 1-1/2"	YW53011200000	21	Hexnut M8x20	YW60062000100
10	Direction connection 1-1/2"	YW51001500000	22	Spring washer 6	YW65006000100
11	Galvanized steel pipe 2	-	23	Flat washer 6	YW66061300000
12	Copper ferrule 1/2"	BH12121200210	24	Screw M6	YW64000600300

* means possible broken parts. ** means easy broken parts. Spare backup is suggested. Please confirm the version number of the manual before you order to ensure the stock number and the parts are consistent.

2.2.21 Refrigerant System Diagram (SIC-18A-R2~24A-R2)

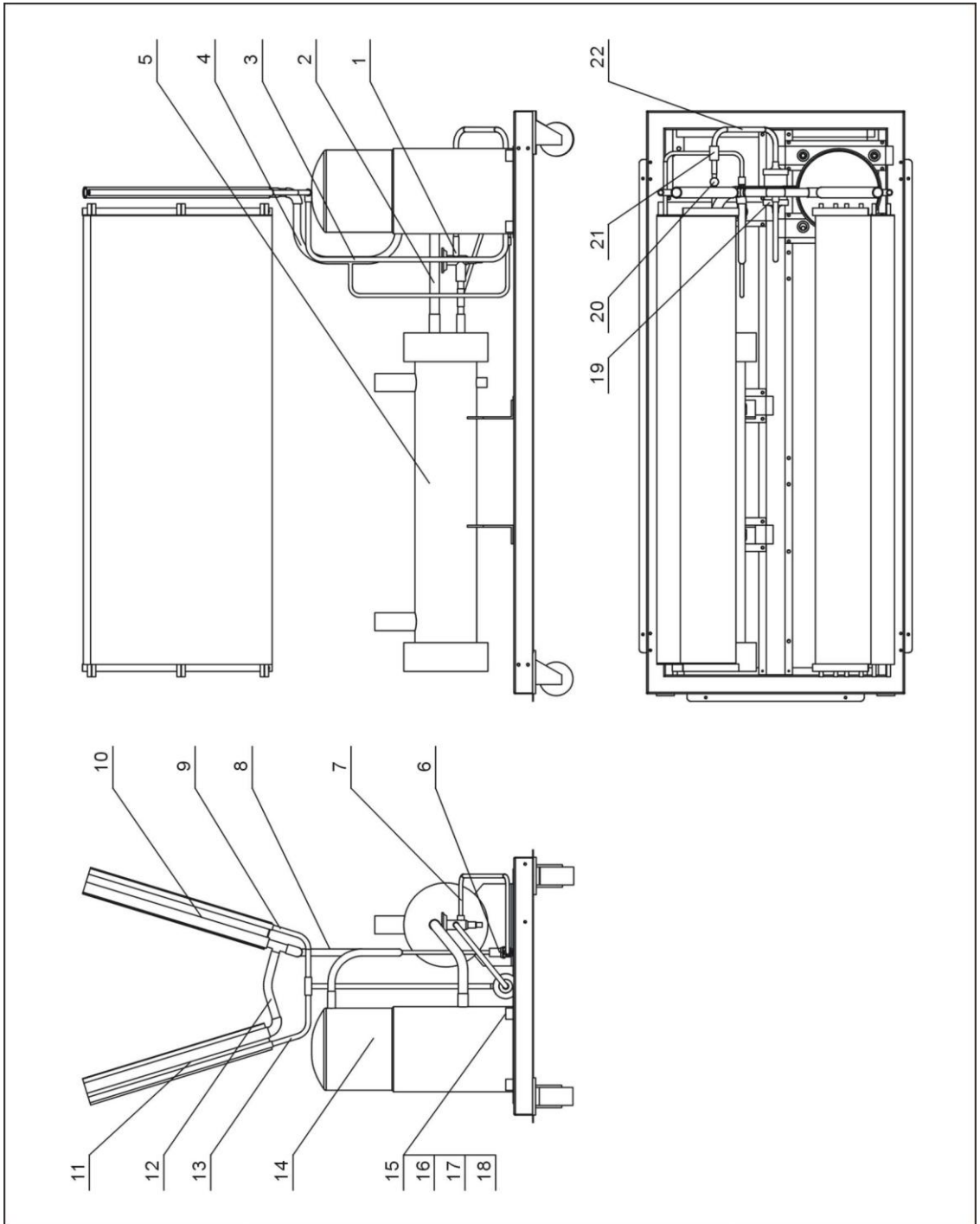

Note: For details of the numbers in the parts drawing, please refer to the part list in 2.2.22

Picture 2-12: Refrigerant System Diagram (SIC-18A-R2~24A-R2)

2.2.22 Refrigerant System Parts List (SIC-18A-R2~24A-R2)

Tabel 2-11: Refrigerant System Parts List (SIC-18A-R2~24A-R2)

No.	Name	Parts No.	No.	Name	Parts No.
1	Thermostate expansion valve	-	12	Exhaust pipe 2	-
2	Air suction pipe	-	13	Liquid pipe 3	-
3	Liquid pipe 1	-	14	Compressor	-
4	Exhaust pipe 1	-	15	Screw M8	YW64080600000
5	Evaporator	-	16	Spring washer 8	YW65008000100
6	Thermostate expansion valve	YE32008300000	17	Flat washer 8	YW66082200100
7	Copper pipe 2	-	18	Hexbolt M8×50	YW60085000000
8	Copper pipe 1	-	19	Dtying filter EK-084S	-
9	Liquid pipe 2	-	20	Refrigerant indicator HMI-1TT4	-
10	Right condenser	-	21	Solenoid valve	-
11	Left condensor	-		Liquid pipe 4	-

* means possible broken parts. ** means easy broken parts. Spare backup is suggested. Please confirm the version number of the manual before you order to ensure the stock number and the parts are consistent.

2.2.23 Genmeral Assembly Diagram (SIC-18A-R2~24A-R2)

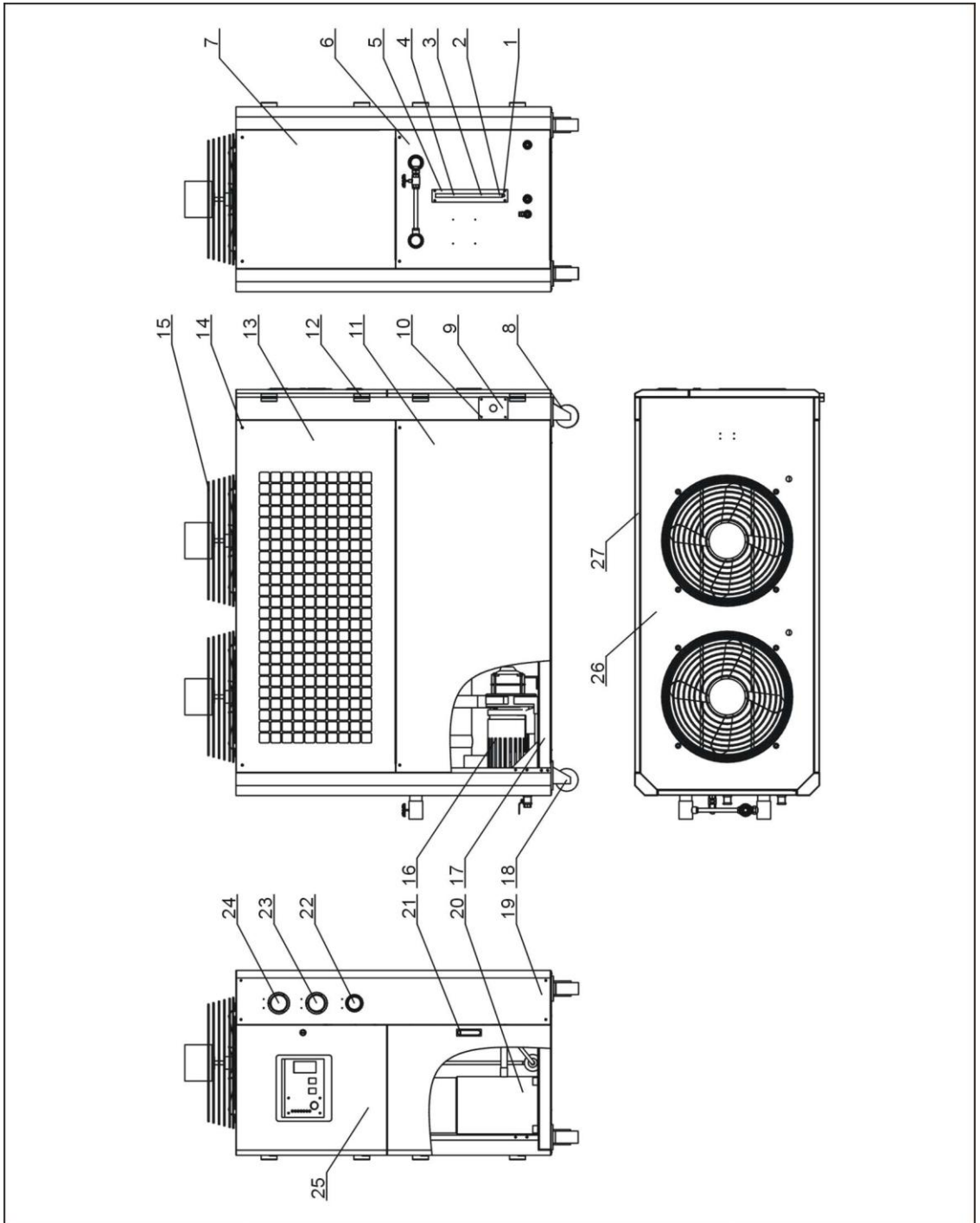

Note: For details of the numbers in the parts drawing, please refer to the part list in 2.2.24

Picture 2-13: Genmeral Assembly Diagram (SIC-18A-R2~24A-R2)

2.2.24 Genmeral Assembly Parts List (SIC-18A-R2~24A-R2)

Table 2-12: Genmeral Assembly Parts List (SIC-18A-R2~24A-R2)

No.	Name	Parts No.	No.	Name	Parts No.
1	Refrigerant indicator base	YW20000000400	15	Fan	-
2	Indicator screw	BH12060700110	16	Water system	-
3	Refrigerant indicator STM-310	BH12030000010	17	Rack	-
4	Glass tube	YW70963000000	18	Movable black castors 3"PP	YW03000300200
5	Indicator cover	BL90006800020	19	Gauge plate	-
6	Lower rear plate	-	20	Refrigerant system	-
7	Upper rear palte	-	21	Door lock	YW00717100000
8	Braking black castors 3"PP	YW03000300000	22	Water pressure gauge	YW85001000100
9	Line jig fixed plate	-	23	Low pressure gauge	YW85003500000
10	Screw M5×10	YW63051000000	24	High pressure gauge	YW85005500000
11	Side plate 1	-	25	Left front door	-
12	Left hinge	YW06203100400	26	Top plate	-
13	Side plate on the left 2	-	27	Side plate on the right 2	-
14	Screw M6×45	YW63064500000			

* means possible broken parts. ** means easy broken parts. Spare backup is suggested. Please confirm the version number of the manual before you order to ensure the stock number and the parts are consistent.

2.2.25 Rack Diagram (SIC-28A-R2~38A-R2)

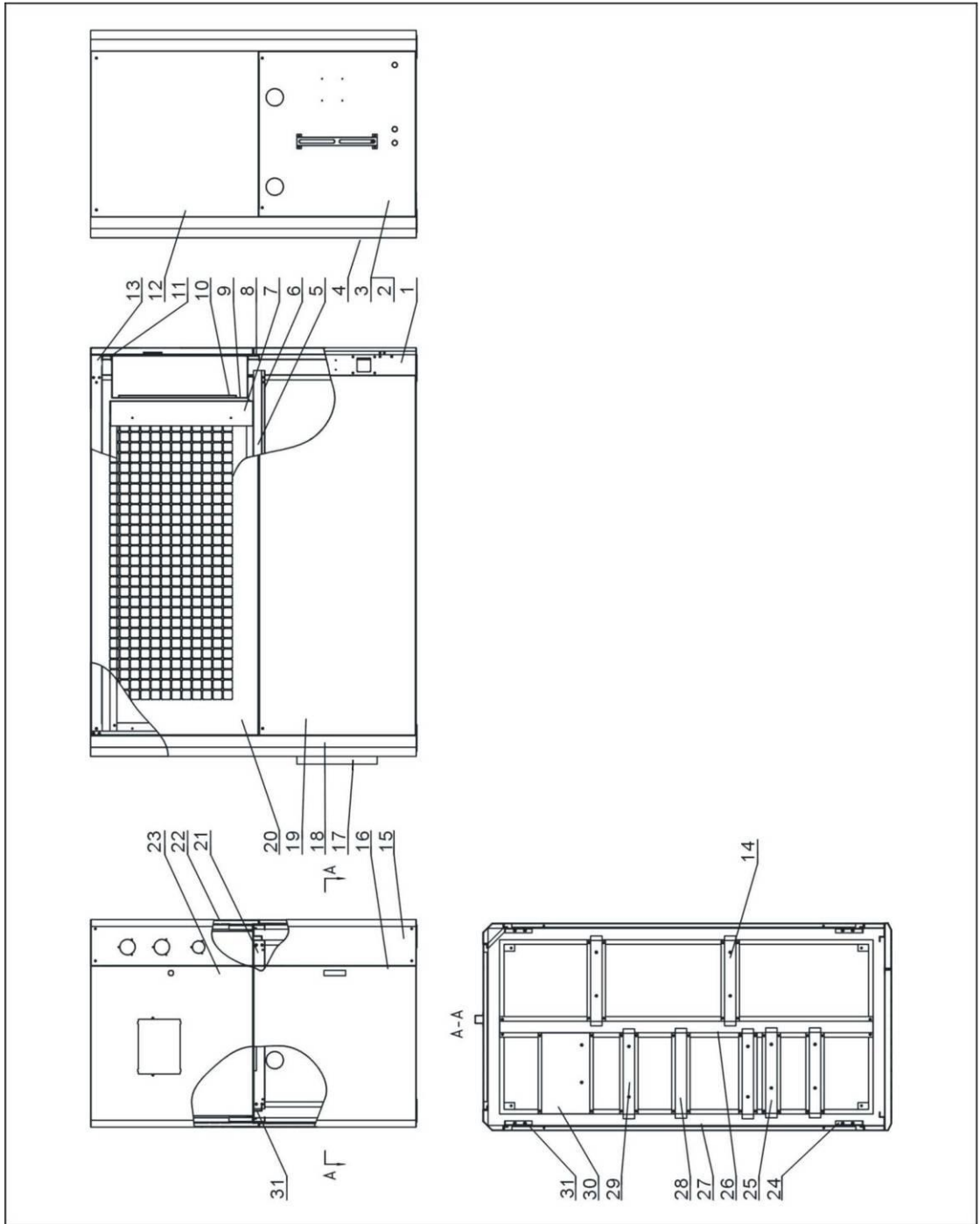

Note: For details of the numbers in the parts drawing, please refer to the part list in 2.2.26

Picture 2-14: Sack Diagram (SIC-28A-R2~38A-R2)

2.2.26 Rack Parts List (SIC-28A-R2~38A-R2)

Table 2-13: Rack Parts List (SIC-28A-R2~38A-R2)

No.	Name	Parts No.	No.	Name	Parts No.
1	Left front stand stand column	-	17	Refrigerant indicator cover	-
2	Rear plate	-	18	Left back stand stand column	-
3	Rear plate3	-	19	Lower side plate	-
4	Right back stand stand column	-	20	Upper side palte on the left	-
5	Lower fan cover	-	21	Back middle beam	-
6	Right middle beam	-	22	Upper side palte on the right	-
7	Front fan cover	-	23	Left front door	-
8	Middle beam 3	-	24	Left triangle supporting	-
9	Electric control cabinet	-	25	Compressor beam	-
10	Base plate of the electric control cabinet	-	26	Middle frame	-
11	Middle beam 2	-	27	Base frame	-
12	Rear plate 2	-	28	Water tank beam	-
13	Top plate	-	29	Water tank fixing beam	-
14	Evaporator beam	-	30	Pump supporting	-
15	Gauge plate	-	31	Right triangle supporting	-
16	Lower left door	-	32	Left middle beam	-

* means possible broken parts. ** means easy broken parts. Spare backup is suggested. Please confirm the version number of the manual before you order to ensure the stock number and the parts are consistent.

2.2.27 Water System & Refrigerant system Diagram (SIC-28A-R2~38A-R2)

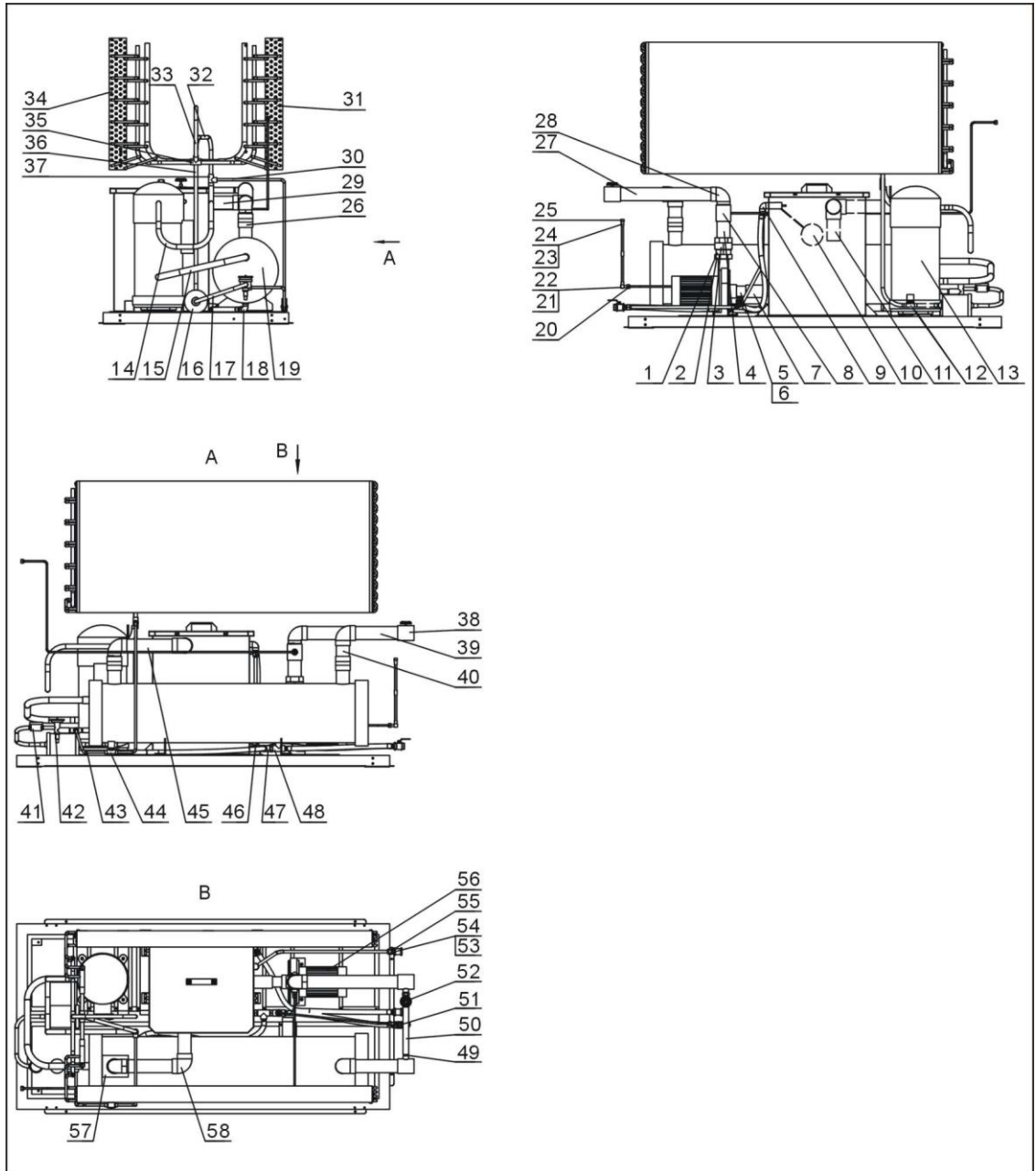

Note: For details of the numbers in the parts drawing, please refer to the part list in 2.2.26

Picture 2-15: Water System & Refrigerant system Diagram

(SIC-28A-R2~38A-R2)

2.2.28 Water System & Refrigerant system Parts List (SIC-28A-R2~38A-R2)

Table 2-14: Water System & Refrigerant system Parts List (SIC-28A-R2~38A-R2)

No.	Name	Stock No.	No.	Name	Stock No.
1	Outer joint 1"×2"	YW57120100000	30	Copper pipe 8	-
2	Galvanized loosen joint 1"	YW50000100000	31	Right condenser	-
3	Galvanized loosen joint 2"	YW54000200000	32	Copper pipe 2	-
4	Pipe 1	-	33	Copper pipe 1	-
5	Pipe 8	-	34	Left condenser	-
6	Pipe 9	-	35	Copper T-connection 5/8"	YW05000500200
7	Black rubber pipe caliber 42 Wall thickness 3	YR60420300000	36	Copper pipe 3	-
8	Galvanized T-connection 2"×1/2"	YW52201200100	37	Copper T-connection 7/8"	YW05000700100
9	Galvanized bend 1/2"	YW53100200100	38	Galvanized T-connection 2" × 1/2"	YW52201200100
10	Floating ball valve 1/2"	YW59010200000	39	Pipe 3	-
11	Pipe 6	-	40	Pipe 2	-
12	Solenoid valve	-	41	Refrigerant indicator	-
13	Compressor	-	42	Expansion valve	-
14	Copper pipe 4	-	43	Copper pipe 5	-
15	Copper pipe 6	-	44	Solenoid valve	-
16	Filter EK305S	-	45	Pipe 5	-
17	Copper pipe 7	-	46	Galvanized inner joint 1/2"	YW50000400000
18	Street elbow 1/2"	YW53121200000	47	Galvanized T-connection 1/2"	YW52100200000
19	Evaporator	-	48	Galvanized T-connection 1/2"	YW52100200000
20	1/4" copper screw	BH12010401010	49	Copper ferrule	BH12161200010
21	Refrigerant indicator base	BW33003100010	50	Steel wire rubber pipe 0.5"	YR60051000000
22	Red single-hole rubber stopper 2/8"	YR30000200100	51	Copper cored valve 1/2"	YW50010200100
23	Refrigerant indicator parts	BH12030000010	52	Sluice valve 1/2"	YW50010200000
24	Glass tube	YW70963000000	53	Copper connector	BH12010200210
25	Indicator nut	BW33003010010	54	Copper nut 4/8"	BH12000401010
26	Pipe 4	-	55	Galvanized direct connection 1/2"	YW51001200000
27	Galvanized street elbow 2"	YW53202000000	56	Pump	-
28	Galvanized direct connection 2"	YW51000200000	57	Flow switch	YW85005000000
29	Pipe 7	-	58	Galvanized bend 2"	YW53000200100

* means possible broken parts. ** means easy broken parts. Spare backup is suggested.

Please confirm the version number of the manual before you order to ensure the stock number and the parts are consistent.

2.2.29 Rack Diagram (SIC-48A-R2~75A-R2)

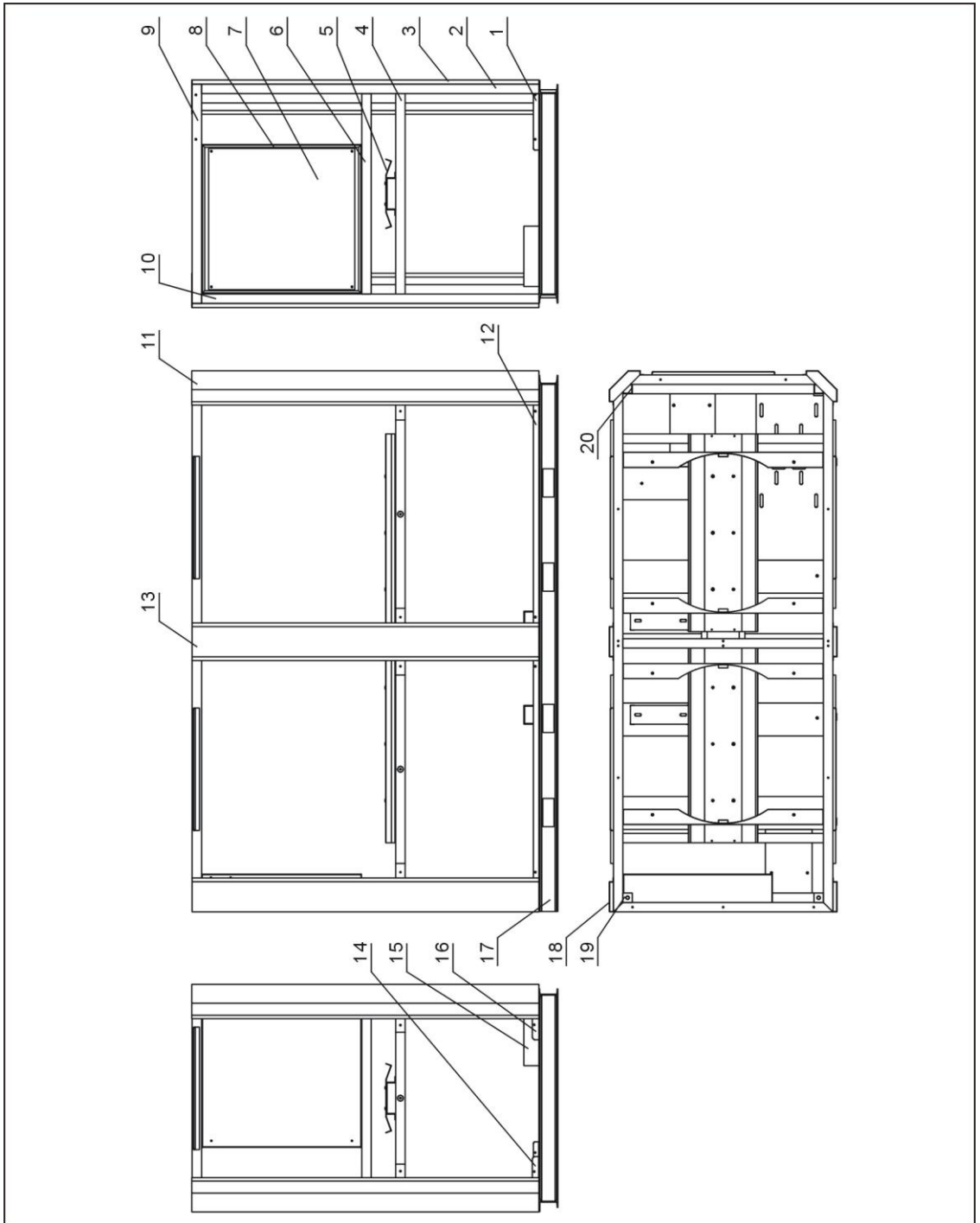

Note: For details of the numbers in the parts drawing, please refer to the part list in 2.2.30.

Picture 2-16: Rack Diagram (SIC-48A-R2~75A-R2)

2.2.30 Rack Parts List (SIC-48A~75A -R2)

Table 2-15: Rack Parts List (SIC-48A~75A -R2)

No.	Name	Stock No.	No.	Name	Stock No.
1	Baffle 1	-	11	Back stand column	-
2	Right main stand column	-	12	Fixed welding piece of side plate	-
3	Right front stand column	-	13	Middle stand column	-
4	Rack middle layer	-	14	Baffle 3	-
5	Base plate of condenser	-	15	Fixed plate of evaporator	-
6	Brace of electrical cabinet	-	16	Baffle 3	-
7	Base plate of electrical cabinet	-	17	Rack base layer	-
8	Electrical cabinet	-	18	Left front stand column	-
9	Rack layer	-	19	Davit	-
10	Left main stand column	-	20	Back main stand column	-

* means possible broken parts. ** means easy broken parts. Spare backup is suggested. Please confirm the version number of the manual before you order to ensure the stock number and the parts are consistent.

2.2.31 Water System Diagram (SIC-48A-R2~75A-R2)

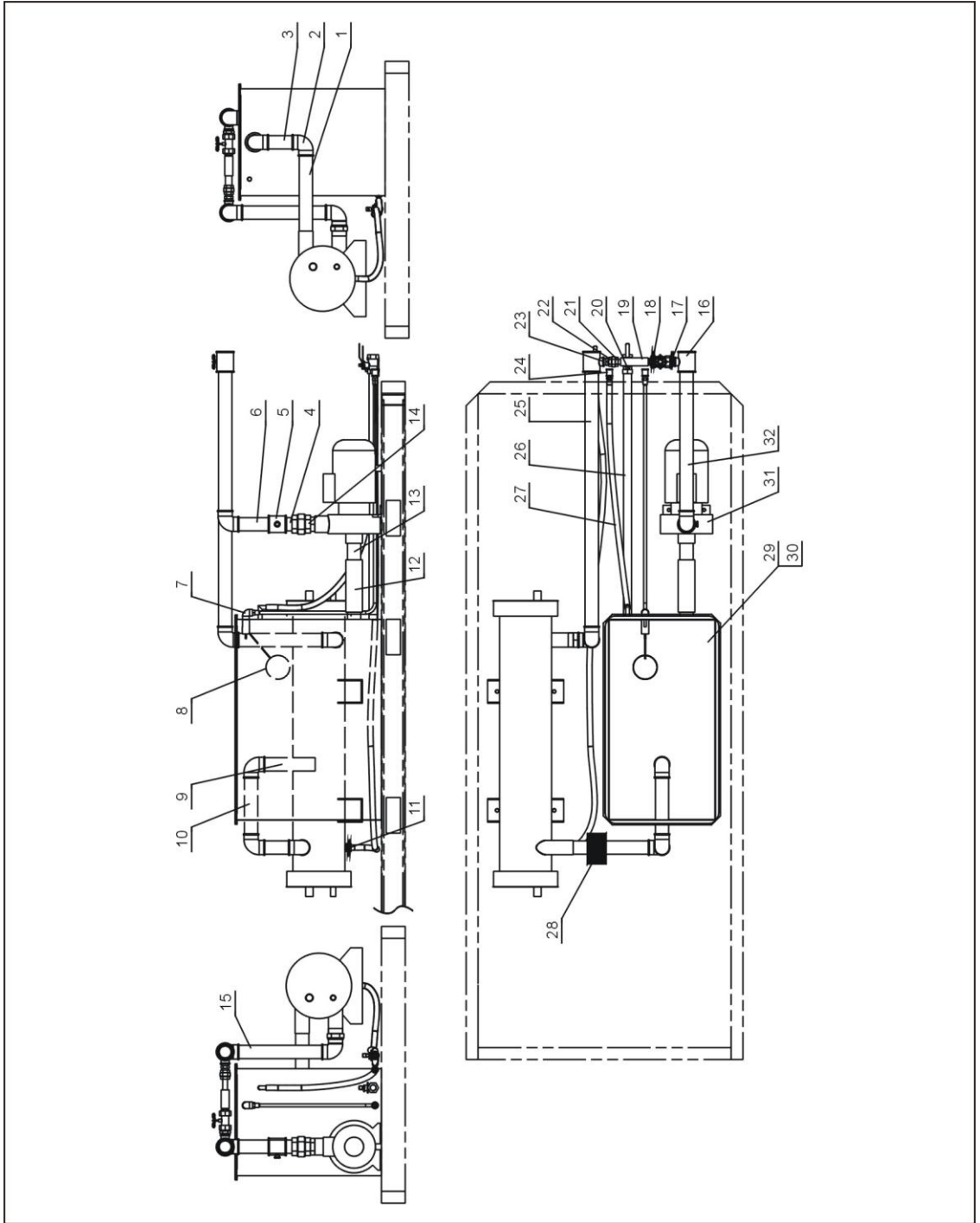

Note: For details of the numbers in the parts drawing, please refer to the part list in 2.232.

Picture 2-17: Water System Diagram (SIC-48A-R2~75A-R2)

2.2.32 Water System Parts List (SIC-48A-R2~75A-R2)

Table 2-16: Water System Parts List (SIC-48A-R2~75A-R2)

No.	Name	Stock No.	No.	Name	Stock No.
1	Evaporator outlet 1	-	17	Galvanized pipe inner joint 1"	YW50000100000
2	Galvanized pipe elbow 2"	YW53000200100	18	Sluice valve 1"	YW50000101000
3	Evaporator outlet 2	-	19	Black rubber pipe inner diameter 32	YR60320500000
4	Galvanized pipe inner joint 2"	YW50000200000	20	Copper globe valve 1"	YW50010000000
5	Galvanized pipe T-joint 2"×1/2"	YW52201200100	21	By-pass pipe	-
6	Pump outlet 1	-	22	Galvanized pipe loose joint 1"	YW54000100000
7	Galvanized pipe elbow 1/2"	YW53100200100	23	Galvanized pipe inner joint 1"	YW50000200000
8	Floating ball switch 1/2"	YW59010200000	24	Galvanized pipe direct connection 1/2"	YW51001200000
9	Evaporator outlet 4	-	25	Return water pipe 1	-
10	Evaporator outlet 3	-	26	Water outlet pipe	-
11	Copper inserted core M16×1/2PT	BH12161200010	27	Wire rubber hose 0.5"	YW85010400100
12	Black rubber pipe inner diameter 60× thickness 3	YR60600300000	28	Flow switch	YW85005000000
13	Pump inlet	-	29	Water tank	-
14	Galvanized pipe loose joint 2"	YW54000200000	30	Water tank cover	-
15	Return water 2	-	31	Pump	-
16	Galvanized pipe T-joint 2" ×1"	YW52020100000			

* means possible broken parts. ** means easy broken parts. Spare backup is suggested. Please confirm the version number of the manual before you order to ensure the stock number and the parts are consistent.

2.2.33 Refrigerant System Diagram (SIC-48A-R2~75A-R2)

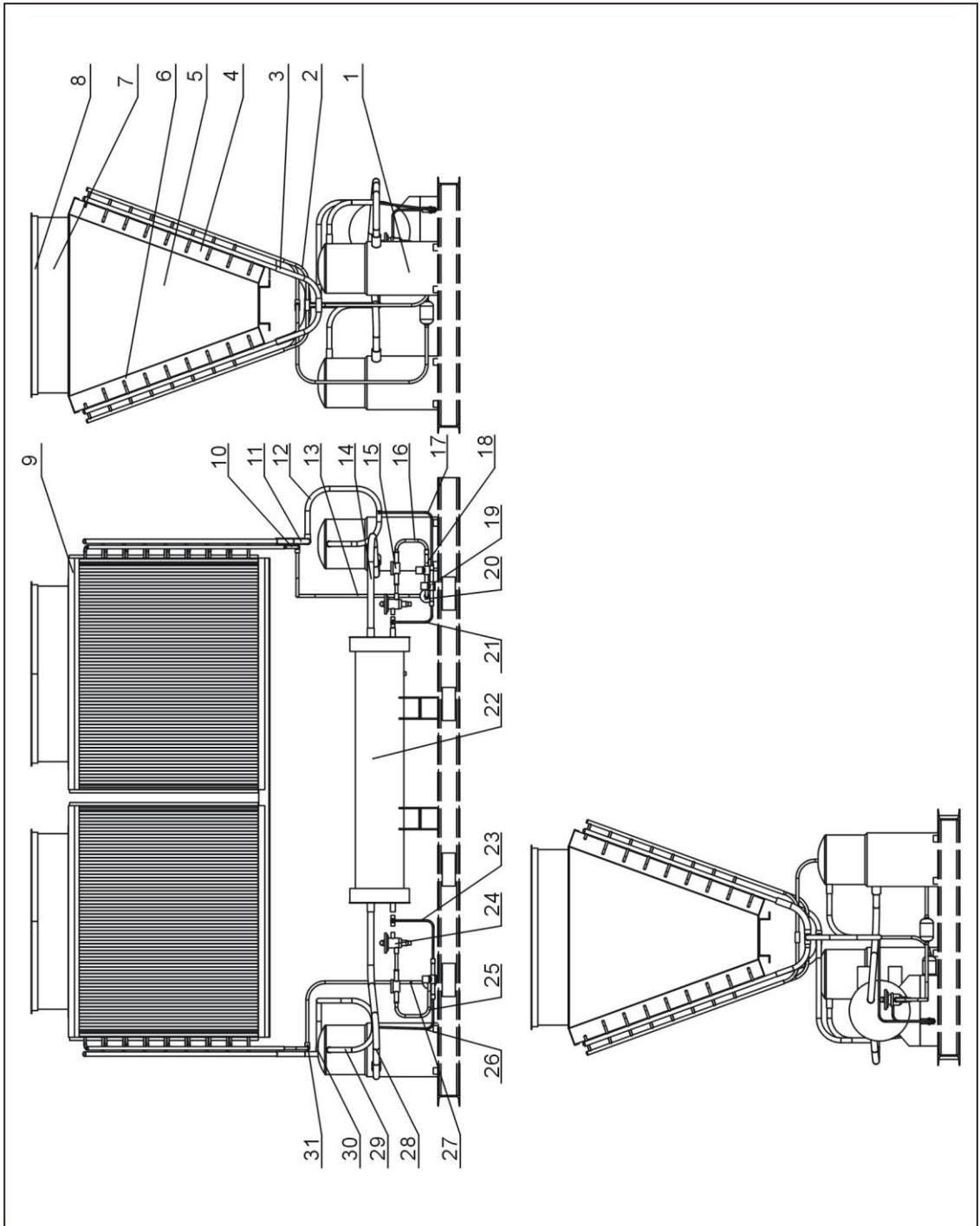

Note: For details of the numbers in the parts drawing, please refer to the part list in 2.2.34.

Picture 2-18: Refrigerant System Diagram (SIC-48A-R2~75A-R2)

2.2.34 Refrigerant Sytem Parts List (SIC-48A-R2~75A-R2)

Table 2-17: Refrigerant Sytem Parts List (SIC-48A-R2~75A-R2)

No.	Name	Stock No.	No.	Name	Stock No.
1	Compressor	-	17	Front chiller by-pass 1	-
2	Back chiller liquid pipe 1	-	18	Solenoid valve	-
3	Back chiller air exhaust pipe 2	-	19	Heat by-pass valve	-
4	Right condenser	-	20	Dryer filter	YW85016400100
5	Base plate of condenser	-	21	Front chiller by-pass 1	-
6	Left condenser	-	22	Evaporator	-
7	Air guide	-	23	Back chiller by-pass 1	-
8	Fan cover	-	24	Expansion valve	-
9	Cover plate of condenser	-	25	Back chiller liquid pipe 2	-
10	Front chiller liquid pipe 1	-	26	Back chiller by-pass 1	-
11	Front chiller air exhaust pipe 2	-	27	Back chiller liquid pipe 3	-
12	Front chiller air exhaust pipe 1	-	28	Back chiller return air pipe	-
13	Front chiller liquid pipe 2	-	29	Back chiller air exhaust pipe 1	-
14	Front return air pipe	-	30	Copper T-joint 7/8"	YW05000700100
15	Refrigerant indicator HMI-1TT4	YW85001400000	31	Copper T-joint 1/2"	YW05000400300
16	Front chiller liquid pipe 3	-			

* means possible broken parts. ** means easy broken parts. Spare backup is suggested. Please confirm the version number of the manual before you order to ensure the stock number and the parts are consistent.

2.2.35 General Assembly Disgram (SIC-48A-R2~75A-R2)

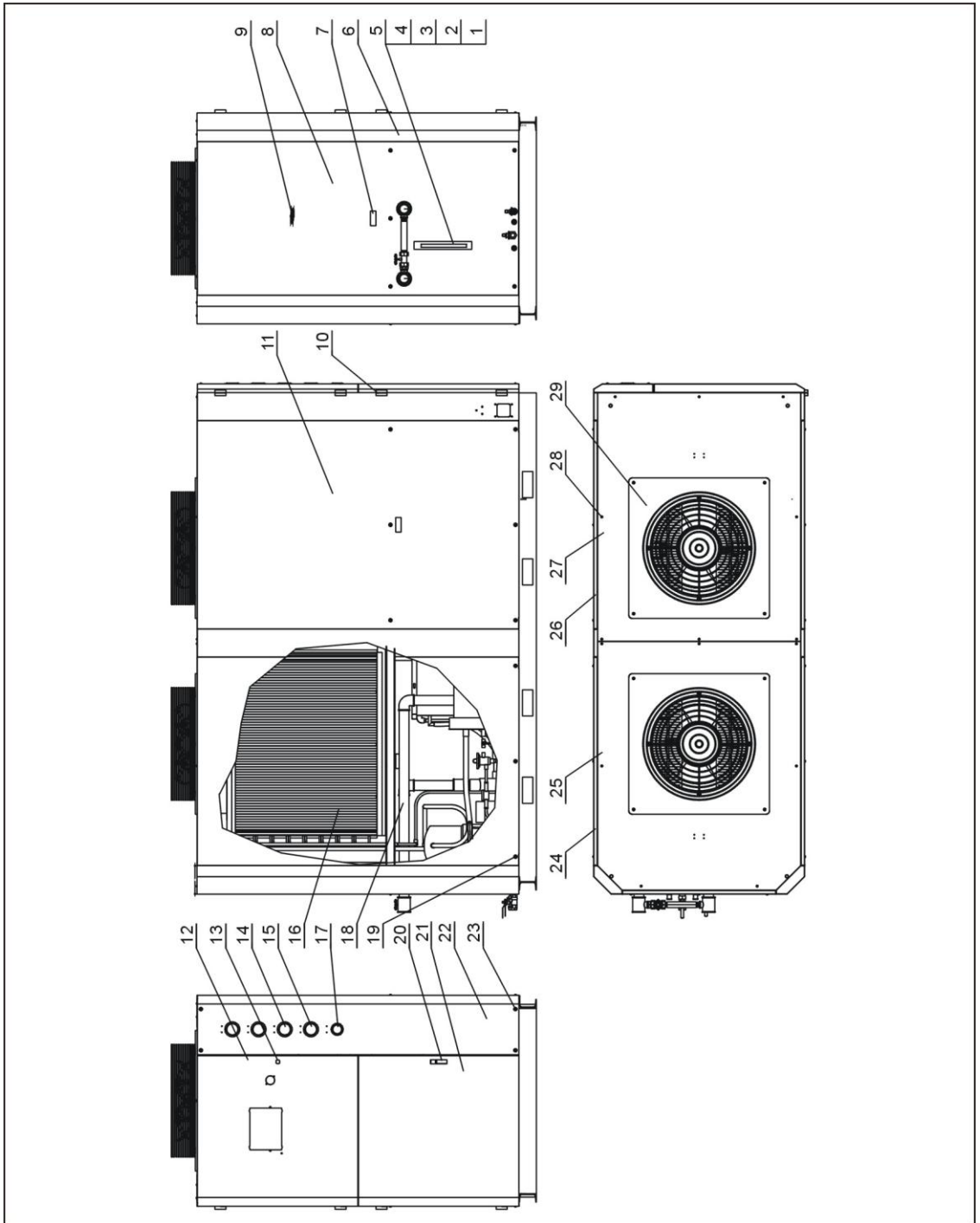

Note: For details of the numbers in the parts drawing, please refer to the part list in 2.2.36.

Picture 2-19: General Assembly Disgram (SIC-48A-R2~75A-R2)

2.2.36 General Assemble Diagram Parts List (SIC-48A-R2~75A-R2)

Table 2-18: General Assemble Diagram Parts List (SIC-48A-R2~75A-R2)

No.	Name	Stock No.	No.	Name	Stock No.
1	Refrigerant indicator base	YW20000000400	16	Refrigerating system	-
2	Refrigerant indicator nut	BH12060700110	17	Pressure gauge 0~10kg	YW85001000100
3	Refrigerant indicator	BH12030000010	18	Chilled water system	-
4	Glass tube	YW70963000000	19	Cross recessed oval head screw M6×30	YW63063000000
5	Refrigerant indicator guard	BL90006800020	20	Door lock	YW00717100000
6	Rack	-	21	Lower plate	-
7	Plastic handle	YR40914040000	22	Gauge plate	-
8	Back plate	-	23	Cross recessed oval head screw M6×60	YW63066200000
9	Back plate 2	-	24	Side plate 2	-
10	Hinge	YW06203100400	25	Back cover plate	-
11	Side plate 3	-	26	Side plate 1	-
12	Upper plate	-	27	Front cover plate	-
13	Door lock	YW00816100000	28	Cross recessed oval head screw M6×10	YW63066200000
14	High pressure guage 0~55kg	YW85005500000	29	Fan	-
15	Low pressureguage 0~35kg	YW85003500000			

** means possible broken parts. ** means easy broken parts. Spare backup is suggested. Please confirm the version number of the manual before you order to ensure the stock number and the parts are consistent.

2.2.37 Rack Diagram (SIC-100A-R2)

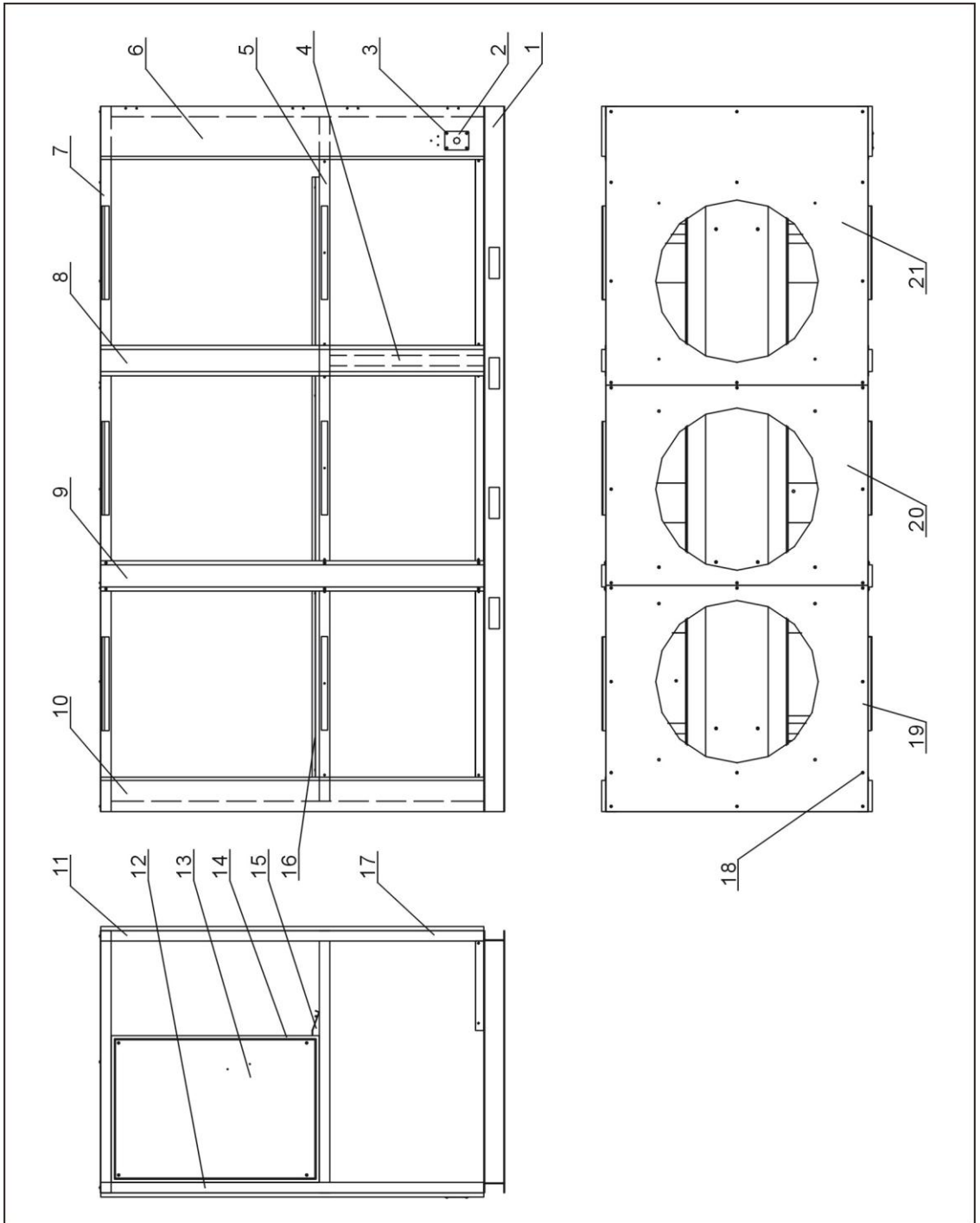

Note: For details of the numbers in the parts drawing, please refer to the part list in 2.2.38.

Picture 2-20: Rack Diagram (SIC-100A-R2)

2.2.38 Rack Parts List (SIC-100A-R2)

Table 2-19: Rack Parts List (SIC-100A-R2)

No.	Name	Stock No.	No.	Name	Stock No.
1	Rack base layer	-	12	Left front brace	-
2	Line jig fixed board	-	13	Base plate of electrical cabinet	-
3	Cross recessed oval head screw M5×15	YW62051500000	14	Electrical cabinet	-
4	Brace 1	-	15	Middle water pond assembly 2	-
5	Rack middle layer	-	16	Middle water pond assembly	-
6	Left front stand column	-	17	Right front stand column	-
7	Rack top layer	-	18	Cross recessed oval head screw M6×15	YW62061500000
8	Middle stand column	-	19	Top plate 1	-
9	Movable stand column	-	20	Top plate 2	-
10	Back stand column	-	21	Top plate 3	-
11	Brace 2	-			

* means possible broken parts. ** means easy broken parts. Spare backup is suggested. Please confirm the version number of the manual before you order to ensure the stock number and the parts are consistent.

2.2.39 Water System Diagram (SIC-100A-R2)

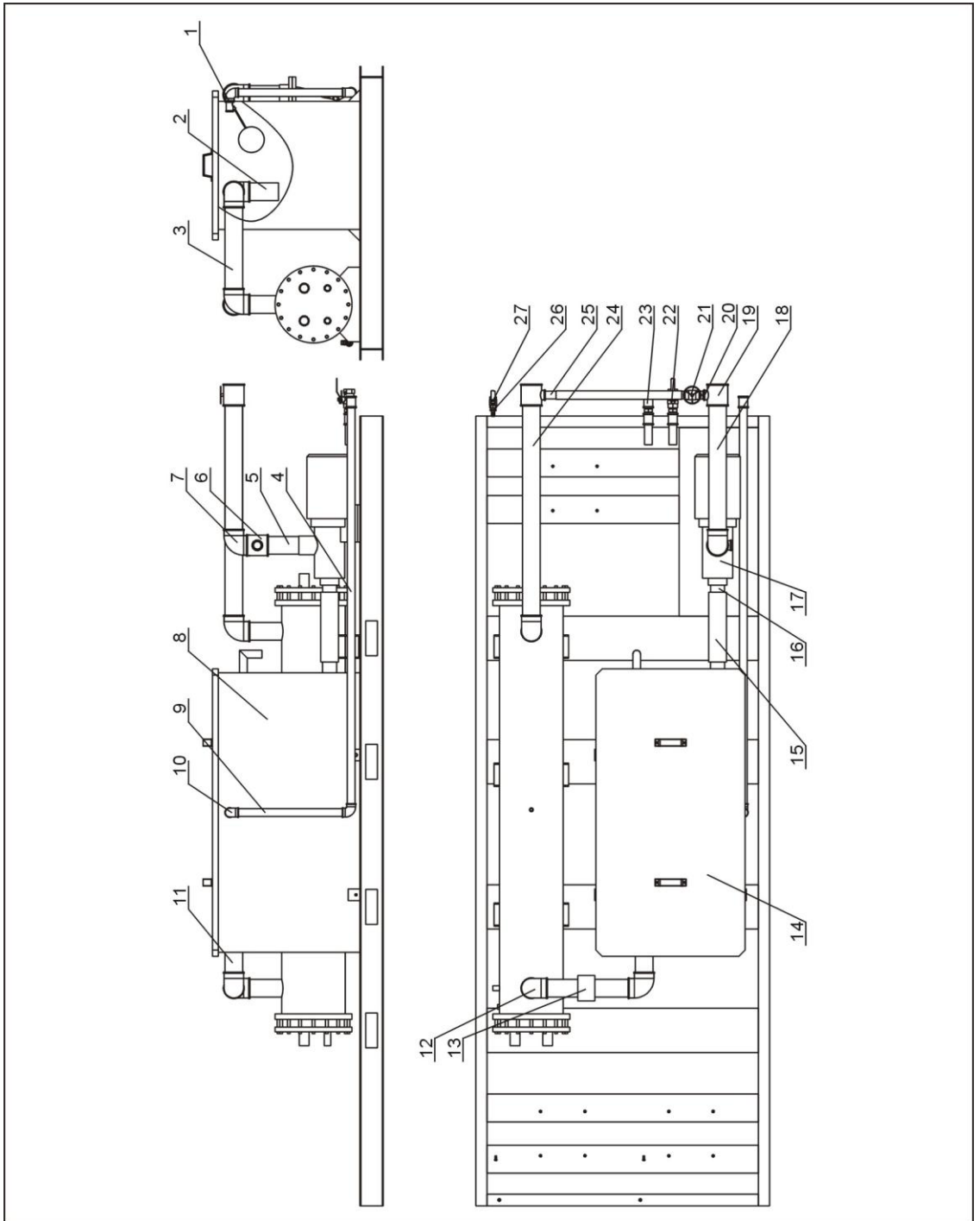

Note: For details of the numbers in the parts drawing, please refer to the part list in 2.2.40.

Picture 2-21: Water System Diagram (SIC-100A-R2)

2.2.40 Water System Parts List (SIC-100A-R2)

Table 2-20: Water System Parts List (SIC-100A-R2)

No.	Name	Stock No.	No.	Name	Stock No.
1	Floating ball switch 1"	YW59010000000	15	Balck rubber pipe 3"	YR60390300000
2	Water pipe 6	-	16	Water pipe 10	-
3	Water pipe 4	-	17	Pump	-
4	Water pipe 9	-	18	Water pipe 2	-
5	Water pipe 1	-	19	Galvanizewd pipe T-joint 2.5" x 1"	YR52250100000
6	Galvanized pipe T-joint 2"x1/2"	YW52201200100	20	Galvanized pipe inner joint 1"	YW50000100000
7	Galvanized pipe street elbow 2" x 1/2"	YW53252500000	21	Sluice valve 1"	YW50000101000
8	Water tank body	-	22	Copper globe valve 1"	YW50010000000
9	Water pipe 8	-	23	Galvanized pipe direct connection 1"	YW51000100000
10	Galvanized pipe elbow 1"	YW53100000000	24	Water pipe 3	-
11	Pipe water 5	-	25	Water pipe 7	-
12	Galvanized pipe elbow 2.5"	YW53002500000	26	Copper inserted core M16x1/2PT	BH12161200010
13	Flow switch	YW85005000000	27	Copper globe valve 1/2"	YW50010200100
14	Water tank cover	-			

* means possible broken parts. ** means easy broken parts. Spare backup is suggested. Please confirm the version number of the manual before you order to ensure the stock number and the parts are consistent.

2.2.41 Refrigerant System Diagram (SIC-100A-R2)

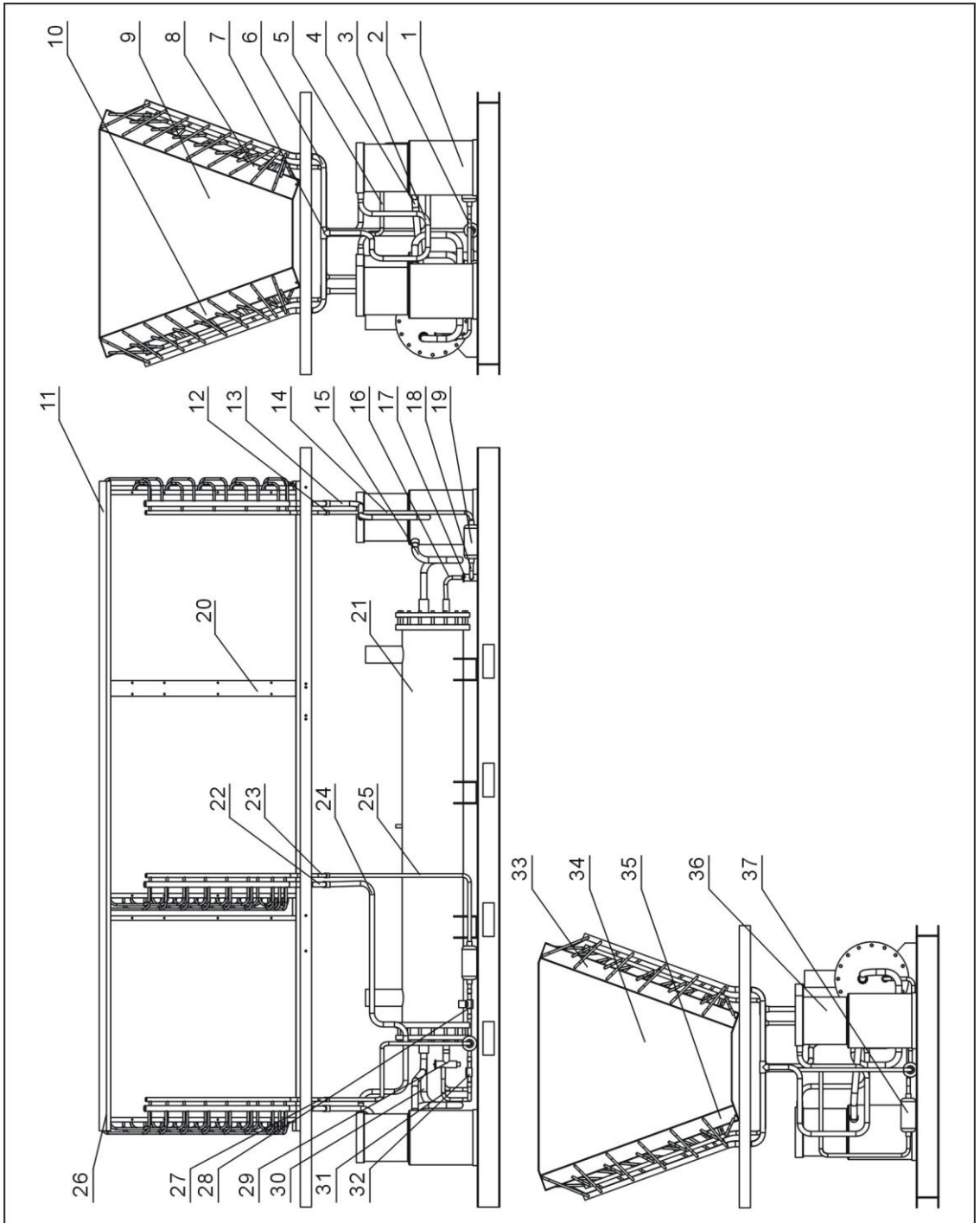

Note: For details of the numbers in the parts drawing, please refer to the part list in 2.2.42.

Picture 2-21: Refrigerant System Diagram (SIC-100A-R2)

2.2.42 Refrigerant Sytem Parts List (SIC-100A-R2)

Table 2-21: Refrigerant Sytem Parts List (SIC-100A-R2)

No.	Name	Stock No.	No.	Name	Stock No.
1	Compressor	-	20	Condenser baffle 3	-
2	Liquid pipe 3	-	21	Evaporator	-
3	Air exhaust pipe 1	-	22	Air exhaust piep 5	-
4	Return air pipe 1	-	23	Liquid pipe 4	-
5	Liquid pipe 2	-	24	Air exhaust pipe 2	-
6	Air exhaust pipe 4	-	25	Liquid pipe 5	-
7	Copper T-joint 7/8"	YW05000700100	26	Condenser cover 2	-
8	Right condenser 1	-	27	Liquid valve 1	-
9	Condenser baffle 1	-	28	Solenoid valve	-
10	Left condenser 1	-	29	Expansion valve	-
11	Condenser cover plate	-	30	Return air pipe 2	-
12	Copper T-joint 5/8"	YW05000500200	31	Liquid pipe 6	-
13	Air exhaust pipe 3	-	32	Refrigerant indicator	-
14	Liquid pipe 7	-	33	Right condenser 2	-
15	Return air pipe 3	-	34	Condenser baffle 2	-
16	Liquid pipe 9	-	35	Left condenser 2	-
17	Expansion valve	-	36	Compressor	-
18	Liquid pipe 8	-	37	Dryer filter	YW85016500100
19	Dryer filter	YW85016400100			

* means possible broken parts. ** means easy broken parts. Spare backup is suggested. Please confirm the version number of the manual before you order to ensure the stock number and the parts are consistent.

2.2.43 General Assembly Diagram (SIC-100A-R2)

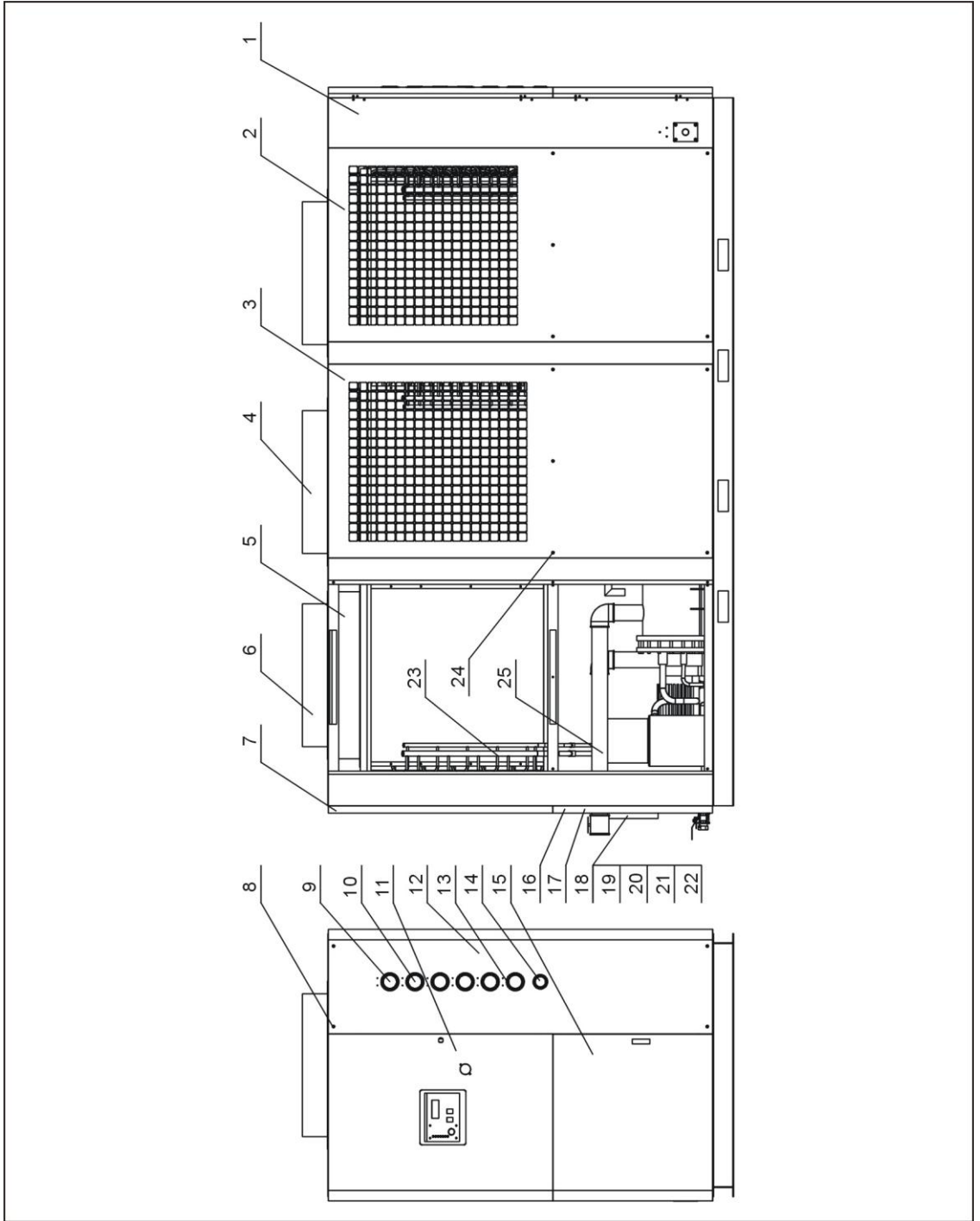

Note: For details of the numbers in the parts drawing, please refer to the part list in 2.2.44.

Picture 2-22: General Assembly Diagram (SIC-100A-R2)

2.2.44 General Assembly Diagram Parts List (SIC-100A-R2)

Table 2-22: General Assemble Diagram Parts List (SIC-100A-R2)

No.	Name	Stock No.	No.	Name	Stock No.
1	Rack	-	14	Water pressure gauge	YW85001000100
2	Side plate 2	-	15	Lower plate	-
3	Side plate 1	-	16	Back plate 2	-
4	Fan	-	17	Back plate 3	-
5	Air guide	-	18	Refrigerant indicator base	YW20000000400
6	Fan	-	19	Refrigerant indicator screw	BH12060700110
7	Back plate 1	-	20	Refrigerant indicator STM-310	BH12030000010
8	Socket head cap screw M6×65	YW61066500100	21	Glass tube	YW70963000000
9	High pressure gauge	YW85005500000	22	Refrigerant indicator guard	BL90006800020
10	Low pressure gauge	YW85003500000	23	Refrigerating system assembly	-
11	Upper door plate	-	24	Cross recessed oval had screw M6×30	YW62063000000
12	Gauge plate	-	25	Chilled water system	-
13	Cross recessed oval head screw M4×10	YW62041000000			

* means possible broken parts. ** means easy broken parts. Spare backup is suggested. Please confirm the version number of the manual before you order to ensure the stock number and the parts are consistent.

2.2.45 Rack Diagram (SIC-114A-R2)

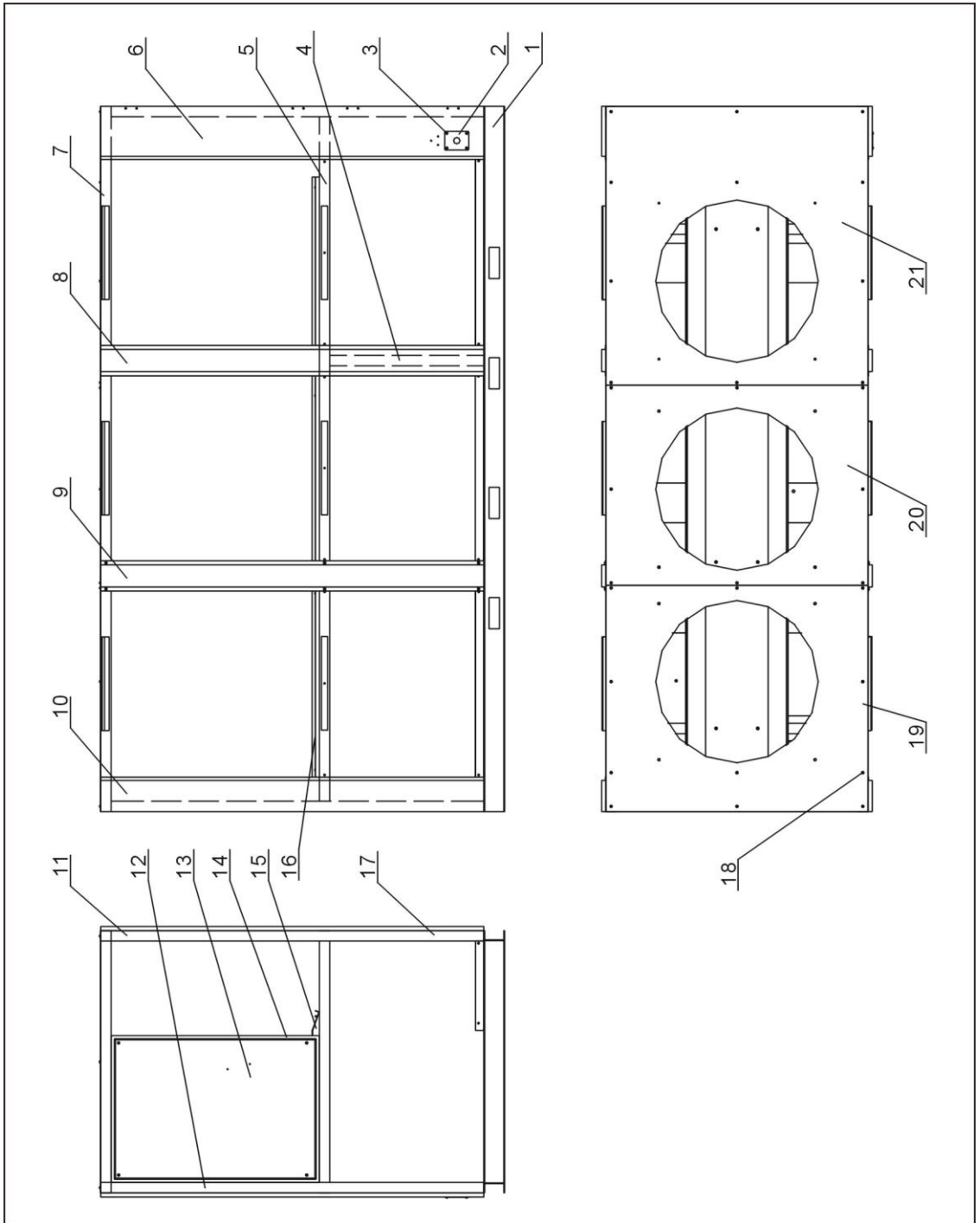

Note: For details of the numbers in the parts drawing, please refer to the part list in 2.2.46.

Picture 2-23: Rack Diagram (SIC-114A-R2)

2.2.46 Rack Parts List (SIC-114A-R2)

Table 2-23: Rack Parts List (SIC-114A-R2)

No.	Name	Stock No.	No.	Name	Stock No.
1	Rack base layer	-	12	Brace 2	-
2	Line jig fixed board	-	13	Left front stand column	-
3	Cros-recessed oval head screw M5×15	YW62051500000	14	Base plate of electrical cabinet	-
4	Brace 1	-	15	Electrical cabinet	-
5	Rack middle layer	-	16	Middle water pond assembly 2	-
6	Middle water pond assembly	-	17	Right front stand column	-
7	Left front stand column	-	18	Cros-recessed oval head screw M6×15	YW62061500000
8	Rack top layer	-	19	Top plate 1	-
9	Middle stand column	-	20	Top plate 2	-
10	Movable stand column	-	21	Top plate 3	-
11	Back stand column	-			

* means possible broken parts. ** means easy broken parts. Spare backup is suggested. Please confirm the version number of the manual before you order to ensure the stock number and the parts are consistent.

2.2.47 Water System Diagram (SIC-114A-R2)

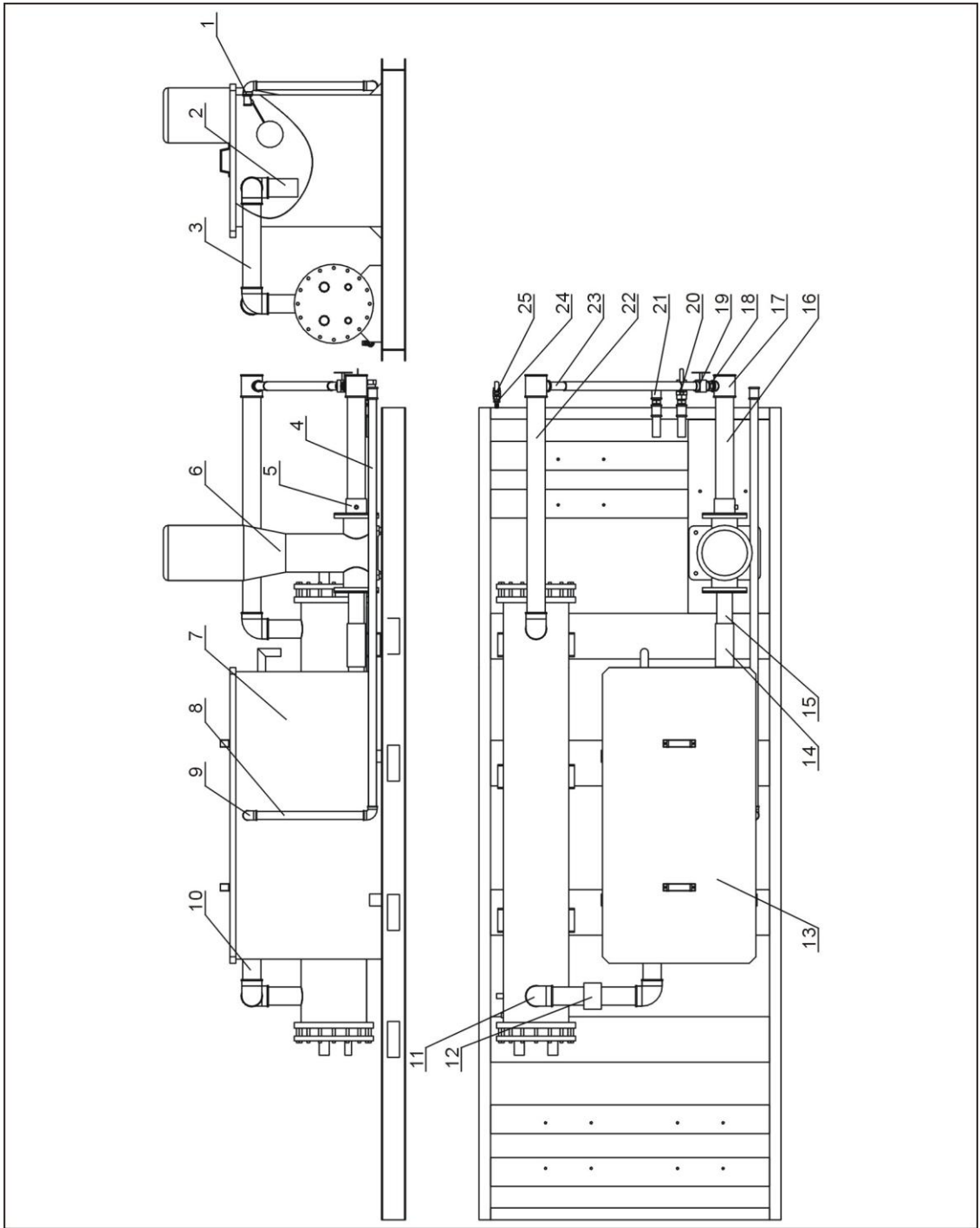

Note: For details of the numbers in the parts drawing, please refer to the part list in 2.2.48.

Picture 2-24: Water System Diagram (SIC-114A-R2)

2.2.48 Water System Parts List (SIC-114A-R2)

Table 2-24: Water System Parts List (SIC-114A-R2)

No.	Name	Stock No.	No.	Name	Stock No.
1	Floating ball valve 1"	YW59010000000	14	Black rubber pipe 3"	YR60390300000
2	Water pipe 6	-	15	Water inlet flange	-
3	Water pipe 4	-	16	Water pipe 1	-
4	Water pipe 9	-	17	Galvanized pipe T-joint 2.5" x 1"	YR52250100000
5	Water outlet flange	-	18	Galvanized pipe inner joint 1"	YW50000100000
6	Pump	-	19	Sluice valve 1"	YW50000101000
7	Water tank body	-	20	Copper globe valve 1"	YW50010000000
8	Water pipe 8	-	21	Galvanized pipe direct connection 1"	YW51000100000
9	Galvanized pipe elbow 1"	YW53100000000	22	Water pipe 3	-
10	Water pipe 5	-	23	Water pipe 7	-
11	Galvanized pipe elbow 2.5"	YW53002500000	24	Copper inserted core M16x1/2PT	BH12161200010
12	Flow switch	YW85005000000	25	Copper globe valve 1/2"	YW50010200100
13	Water tank cover	-			

* means possible broken parts. ** means easy broken parts. Spare backup is suggested. Please confirm the version number of the manual before you order to ensure the stock number and the parts are consistent.

2.2.49 Refrigerant System Diagram (SIC-114A-R2)

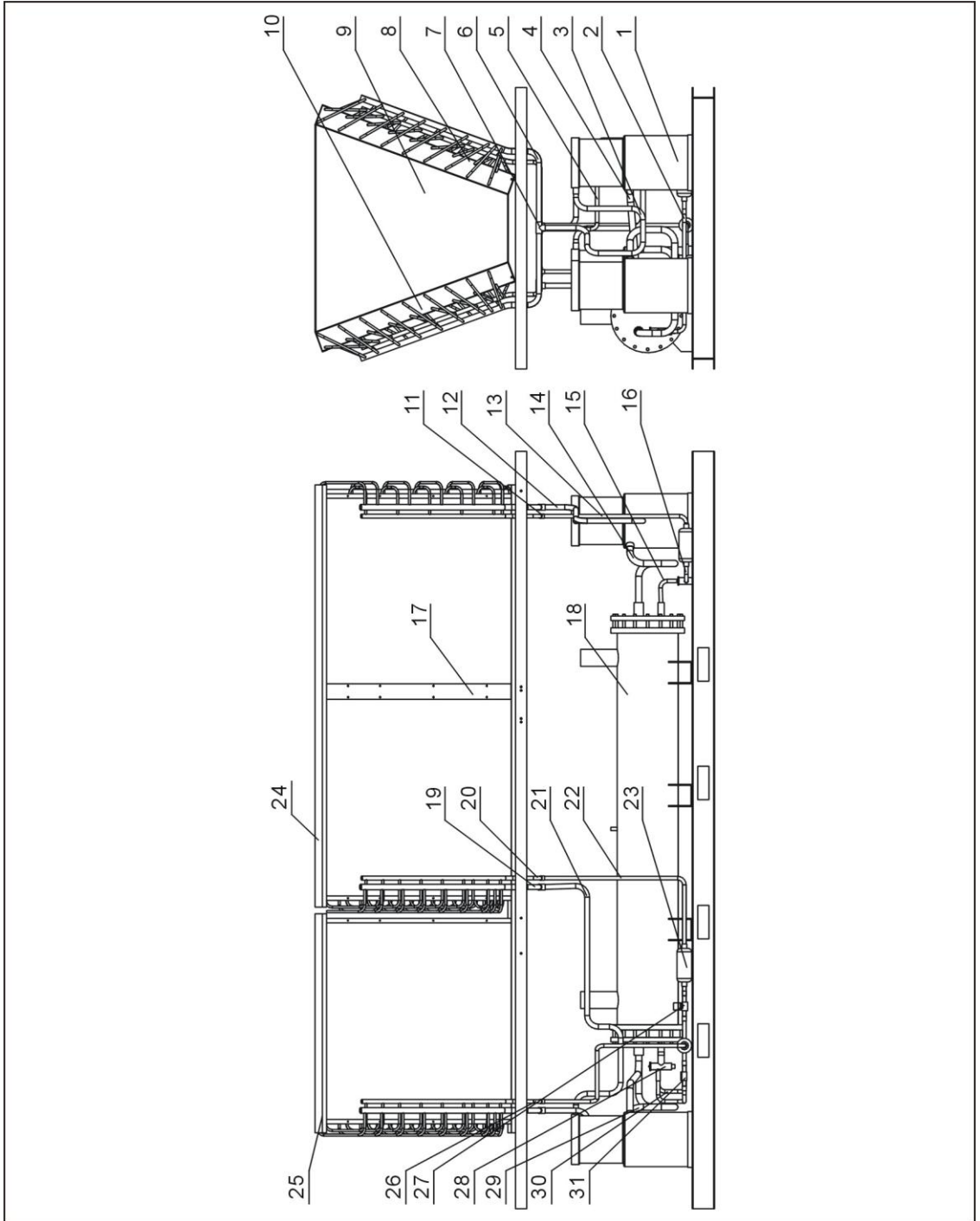

Note: For details of the numbers in the parts drawing, please refer to the part list in 2.2.50.

Picture 2-25: Refrigerant System Diagram (SIC-114A-R2)

2.2.50 Refrigerant System Parts List (SIC-114A-R2)

Table 2-25: Refrigerant System Parts List (SIC-114A-R2)

No.	Name	Stock No.	No.	Name	Stock No.
1	Compressor	-	17	Condenser baffle 3	-
2	Liquid pipe 3	-	18	Evaporator	-
3	Air exhaust pipe 1	-	19	Air exhaust pipe 5	-
4	Return air pipe 1	-	20	Liquid pipe 4	-
5	Liquid pipe 2	-	21	Air exhaust pipe 2	-
6	Air exhaust pipe 4	-	22	Liquid pipe 5	-
7	Copper T-joint 7/8"	YW05000700100	23	Dryer filter	YW85016500100
8	Right condenser 1	-	24	Condenser cover plate	-
9	Condenser baffle 1	-	25	Condenser cover 2	-
10	Left condenser 1	-	26	Liquid valve 1	-
11	Copper T-joint 5/8"	YW05000500200	27	Solenod valve	-
12	Air exhaust pipe 3	-	28	Expansion valve	-
13	Liquid pipe 7	-	29	Return air pipe 2	-
14	Return air pipe 3	-	30	Liquid pipe 6	-
15	Liquid pipe 9	-	31	Refrigerant indicator	-
16	Liquid pipe 8	-			

* means possible broken parts. ** means easy broken parts. Spare backup is suggested. Please confirm the version number of the manual before you order to ensure the stock number and the parts are consistent.

2.2.51 General Assembly Diagram (SIC-114A-R2)

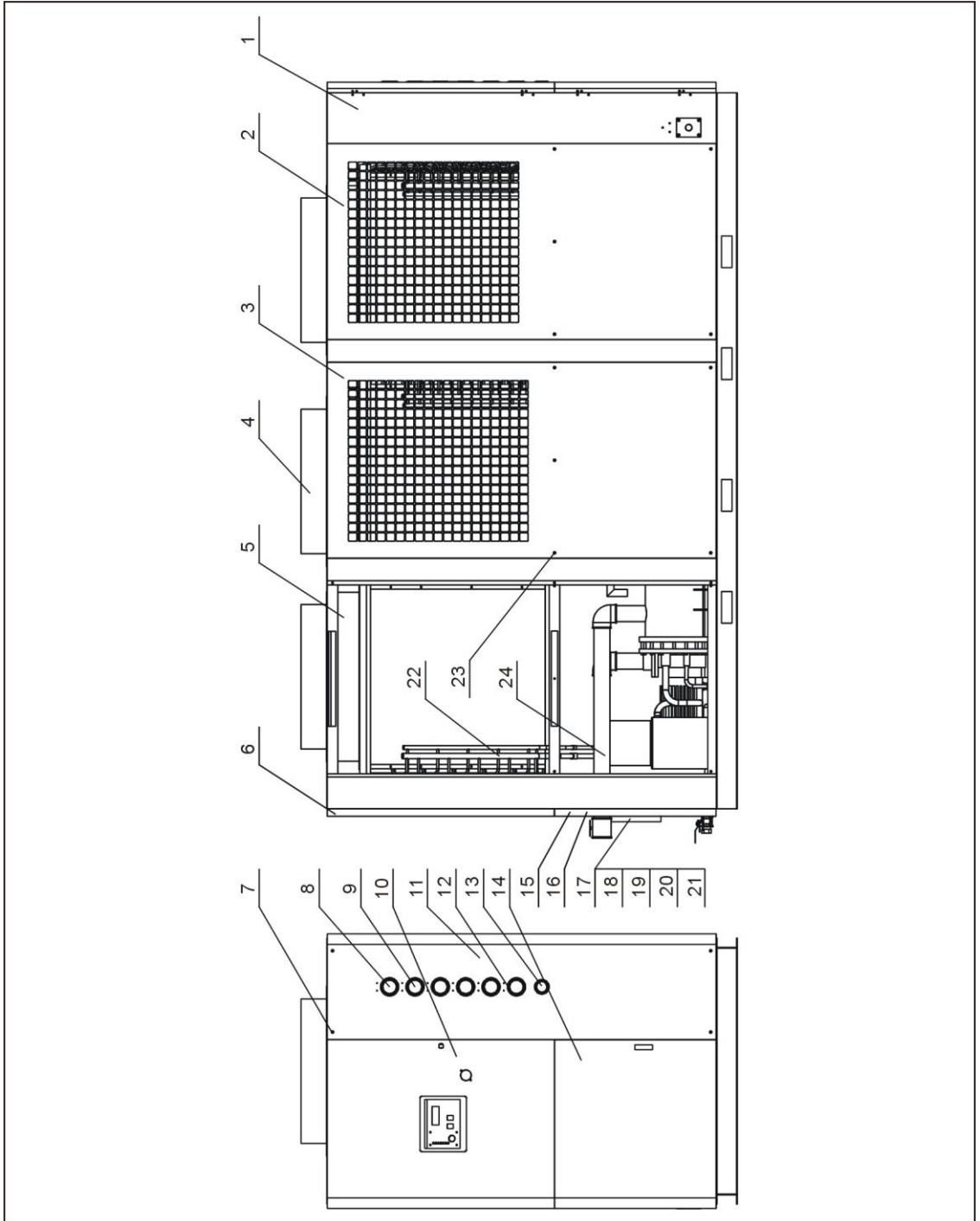

Note: For details of the numbers in the parts drawing, please refer to the part list in 2.2.52.

Picture 2-26: General Assembly Diagram (SIC-114A-R2)

2.2.52 General Assembly Diagram Parts List (SIC-114A-R2)

Table 2-26: General Assembly Diagram Parts List (SIC-114A-R2)

No.	Name	Stock No.	No.	Name	Stock No.
1	Rack	-	13	Water pressure gauge	YW85001000100
2	Side plate 2	-	14	Lower door plate	-
3	Side plate 1	-	15	Back plate 2	-
4	Fan	YM60650650000	16	Back plate 3	-
5	Air guide	-	17	Refrigerant indicator base	YW20000000400
6	Back plate 1	-	18	Refrigerant indicator screw	BH12060700110
7	Socket head cap screw M6×65	YW61066500100	19	Refrigerant indicator STM-310	BH12030000010
8	High pressure gauge	YW85005500000	20	Glass tube	YW70963000000
9	Low pressure gauge	YW85003500000	21	Refrigeration indicator	BL90006800020
10	Upper door plate	-	22	Refrigerating system assembly	-
11	Gauge plate	-	23	Cross recessed oval head screw M6×30	YW62063000000
12	Cross recessed oval head screw M4×10	YW62041000000	24	Cooling water system	-

** means possible broken parts. ** means easy broken parts. Spare backup is suggested. Please confirm the version number of the manual before you order to ensure the stock number and the parts are consistent.

2.2.53 Main Parts and Functions

2.2.53.1 Compressor

- 1) Compressing and conveying the refrigeration steam and forming low pressure in evaporator and high pressure in condenser, the compressor is the core of the whole system.
- 2) SIC-A-R2 adopts scroll compressor.



Picture 2-27: Compressor

2.2.53.2 Condenser

- 1) Condenser is a heat output device which is used to discharge the heat absorbed by the evaporator and converted by the compressor to the cooling medium.
- 2) SIC-A-R2 adopts fin-style condenser.



Picture 2-28: Condenser

2.2.53.3 Drying Filter

- 1) The functions of the dry filter are: clean the impurity in the refrigerant, absorb the free moisture in the refrigerant, and prevent the narrow section (especially the valve port of the heat expansion valve) of the pipe from forming ice jam.
- 2) The size of the filter is usually chosen according to the caliber of the cooling

agent pipe.

- 3) The dry filter is installed in front of the heat expansion valve and solenoid valve (optional) to maintain the strictness of the valve. .



Picture 2-29: Drying Filter

2.2.53.4 Heat Expansion Valve

- 1) The heat expansion valve is used to take the effect of throttle and pressure relief, and also adjust the flow quantity of the cooling agent going into the evaporator.
- 2) The heat expansion valve is usually installed before the evaporator.



Picture 2-30: Heat Expansion Valve

2.2.53.5 Evaporator

- 1) The evaporator is the equipment which output the refrigerating capacity, in which the cooling agent absorb the heat of the cooled objects and achieve the aim of refrigeration.
- 2) SIC-A-R2 adopts adopts tube-in-shell horizontal evaporator.



Picture 2-31: Evaporator

2.2.53.6 High and Low Pressure Controllers

- 1) The high and low pressure controllers are used to control the working pressure of the compressor suction port and outlet port.
- 2) The pressure of the high pressure controller is set to 37 bar, and pressure of the low pressure controller is set to 4 bar.
- 3) Give an alarm when the pressure of the compressor outlet port is higher than 37 bar or the pressure of the compressor suction port is lower than 4 bar.



Picture 2-32: High and Low Pressure Controller

2.2.53.7 Refrigerant Indicator (optional)



Picture 2-33: Refrigerant Indicator

- 1) The refrigerant indicator is used to detect whether the refrigerant is filled appropriately.
- 2) The refrigerant indicator is used to detect the water ratio of the system.

3) The refrigerant indicator is installed in front of expansion valve.

2.2.53.8 Solenoid Valve (optional)



Picture 2-34: Solenoid Valve

1) Solenoid valve is used to cut the refrigerant supply immediately after the machine stops to prevent the compressor freezing.

2) Solenoid valve is installed in front of the refrigerant indicator.

2.2.53.9 Heat By-pass Valve (optional)



Picture 2-35: Heat By-pass Valve

1) Heat by-pass valve is used to bypass the cooling refrigerant when the temperature is low to prevent frequent starts and stops of the compressor and achieve accurate temperature control.

2) Heat by-pass valve is installed on the connecting pipe of the compressor outlet and expansion valve outlet.

2.2.53.10 Flow Switch (optional)



Picture 2-36: Flow Switch

- 1) Flow switch is adopted to detect whether the chilled water flow is sufficient.
- 2) Flow switch is installed on the water pipe between the evaporator and the water tank.

2.2.53.11 Liquid Level Indicator (optional)



Through the liquid level indicator, the water level in the tank can be viewed.

2.3 Electrical Circuit

2.3.1 Selection Table of Pump Contactor and Thermal Overload Relay (400V)

Table 2-27: Selection Table of Pump Contactor and Thermal Overload Relay

(Low Pressure) (400V)

Model	Power (kw)	Stock No.	
		Contactora	Thermal Overload Relay
SIC-7.5A-R2	0.75	YE00601521000	YE01160220000
SIC-12A-R2	0.75	YE00601521000	YE01160220000
SIC-18A-R2	1.1	YE00601521000	YE01160280000
SIC-24A-R2	1.1	YE00601521000	YE01160280000
SIC-28A-R2	1.1	YE00601521000	YE01160280000
SIC-38A-R2	1.1	YE00601521000	YE01160280000
SIC-48A-R2	2.2	YE00601521000	YE01160450000
SIC-58A-R2	2.2	YE00601521000	YE01160450000
SIC-75A-R2	2.2	YE00601521000	YE01160450000
SIC-100A-R2	3.0	YE00601621000	YE01167100000
SIC-114A-R2	4.0	YE00601721000	YE01169125000

Table 2-28: Selection Table of Pump Contactor and Thermal Overload Relay

(Medium Pressure) (400V)

Model	Power (kw)	Stock No.	
		Contactora	Thermal Overload Relay
SIC-7.5A-R2-P	0.75	YE00601521000	YE01160220000
SIC-12A-R2-P	0.75	YE00601521000	YE01160220000
SIC-18A-R2-P	1.1	YE00601521000	YE01160280000
SIC-24A-R2-P	1.1	YE00601521000	YE01160280000
SIC-28A-R2-P	1.1	YE00601521000	YE01160350000
SIC-38A-R2-P	1.1	YE00601521000	YE01160350000
SIC-48A-R2-P	3.0	YE00601621000	YE01167100000
SIC-58A-R2-P	3.0	YE00601621000	YE01167100000
SIC-75A-R2-P	3.0	YE00601621000	YE01167100000

SIC-100A-R2-P	3.0	YE00601621000	YE01167100000
SIC-114A-R2-P	4.0	YE00601721000	YE01169125000

Table 2-29: Selection Table of Pump Contactor and Thermal Overload Relay

(High Pressure) (400V)

Model	Power (kw)	Stock No.	
		Contactora	Thermal Overload Relay
SIC-7.5A-R2-HP	1.1	YE00601521000	YE01160280000
SIC-12A-R2-HP	1.1	YE00601521000	YE01160280000
SIC-18A-R2-HP	1.1	YE00601521000	YE01160280000
SIC-24A-R2-HP	1.1	YE00601521000	YE01160280000
SIC-28A-R2-HP	2.2	YE00601521000	YE01160450000
SIC-38A-R2-HP	2.2	YE00601521000	YE01160450000
SIC-48A-R2-HP	4.0	YE00601721000	YE01169125000
SIC-58A-R2-HP	4.0	YE00601721000	YE01169125000
SIC-75A-R2-HP	4.0	YE00601721000	YE01169125000
SIC-100A-R2-HP	4.0	YE00601721000	YE01169125000
SIC-114A-R2-HP	5.5	YE00601800000	YE01611640000

2.3.2 Main Electrical Circuit (SIC-7.5A-R2) (400V)

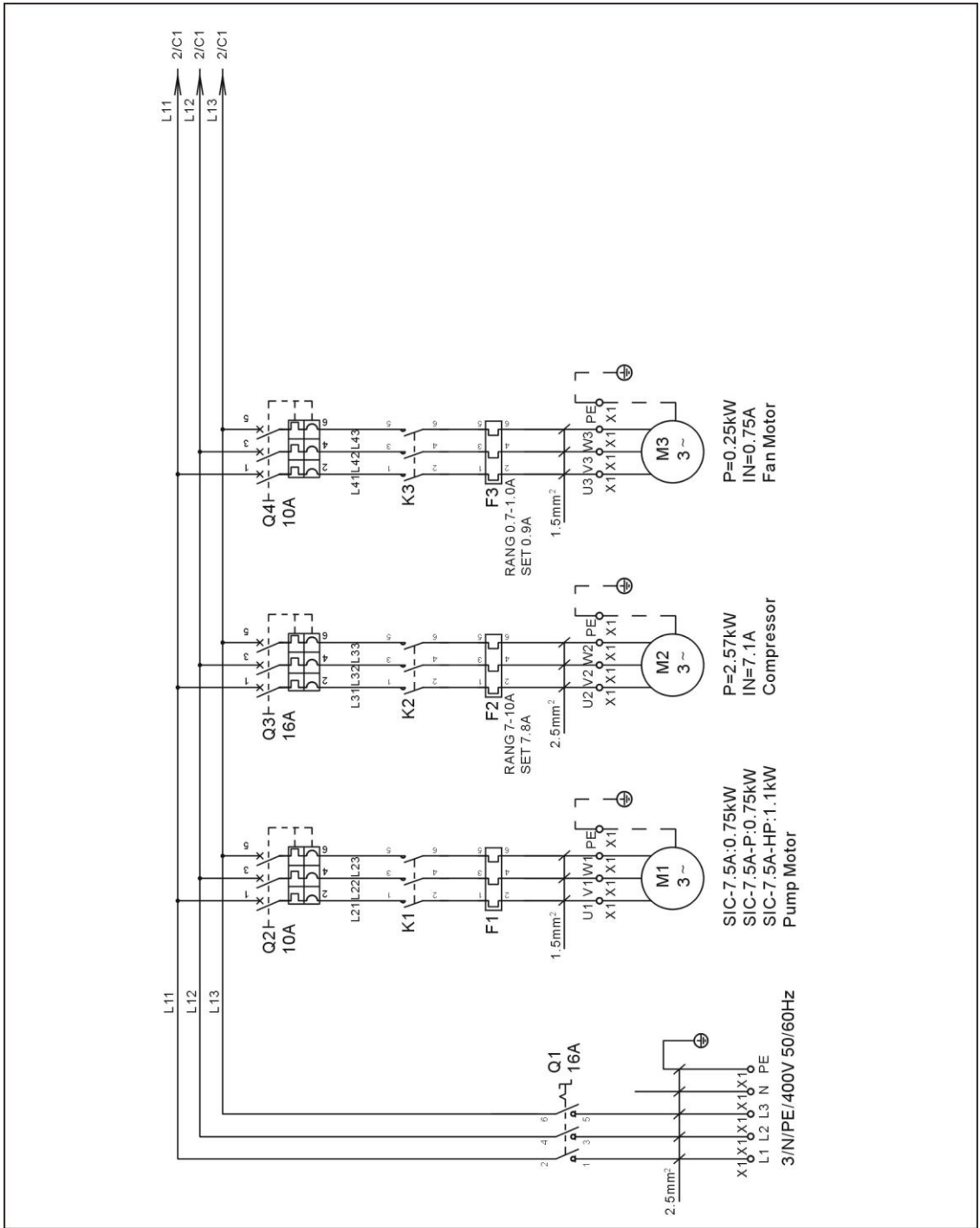

Picture 2-37: Main Electrical Circuit (SIC-7.5A-R2) (400V)

2.3.3 Control Circuit (SIC-7.5A-R2) (400V)

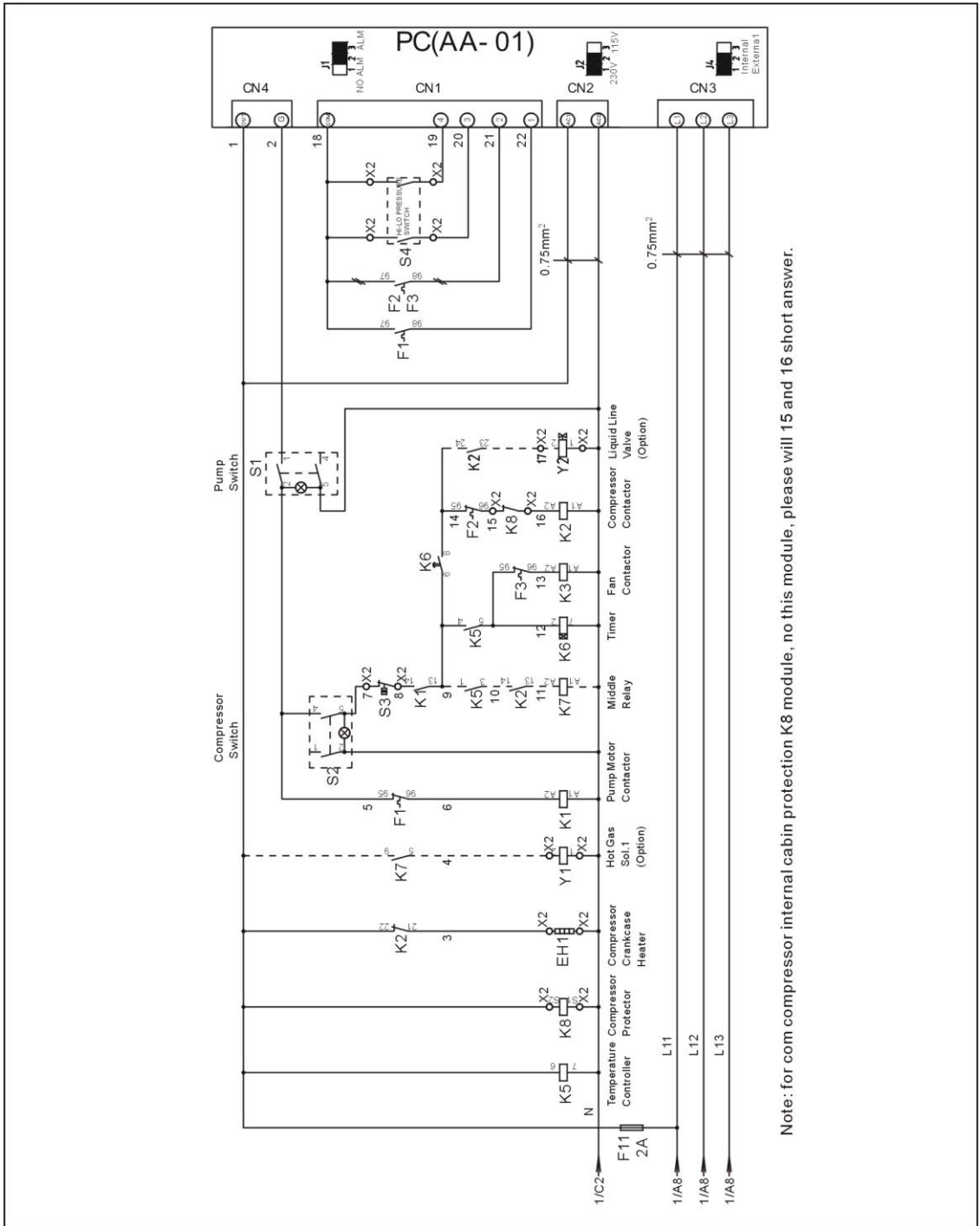

Picture 2-38: Control Circuit (SIC-7.5A-R2) (400V)

2.3.4 Electrical Components Layout (SIC-7.5A-R2) (400V)

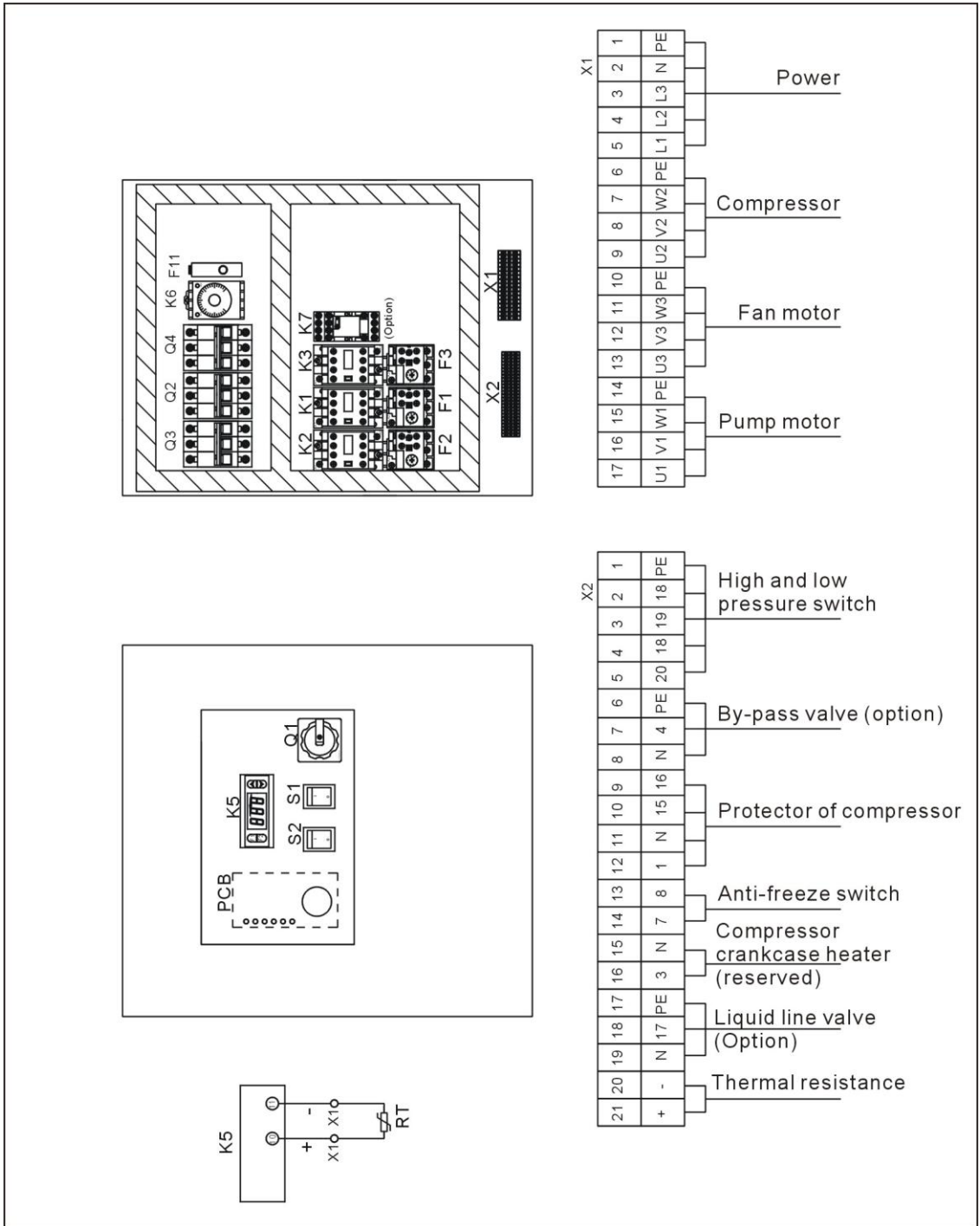

Picture 2-39: Electrical Components Layout (SIC-7.5A-R2) (400V)

2.3.5 Electrical Components List (SIC-7.5A-R2) (400V)

Table 2-30: Electrical Components List (SIC-7.5A-R2) (400V)

No.	Symbol	Name	Specificatons	Parts No.
1	Q1	Main switch	16A	YE10021160000
2	Q3	Circuit breaker *	16A	YE40601500000
3	Q2 Q4	Circuit breaker *	10A	YE40600300000
4	K1	Contactor *	220VAC 50/60Hz	-
5	K2	Contactor *	220VAC 50/60Hz	YE00601722000
6	-	Auciliary block	2NO+2NC	YE00691110000
7	K3	Contactor *	220VAC 50/60Hz	YE00601521000
8	K5	Temperature controller *	115~230VAC	YE85120200000
9	K6	Timer	3S-60M AC220V	YE86300300000
10	K7	Middle realy	AC220V	YE03270700000
11	F1	Overload relay *	-	-
12	F2	Overload relay *	7~10A	YE01167100000
13	F3	Overload relay *	0.7~1A	YE01160700000
14	F11	Fuse**	2A	YE41001000000
15	S1 S2	Control switch *	250V~10(5)A 4P WH	YE10210400000
16	S3	Anti-frozen switch *	-	-
17	S4	HI-LO pressure switch	-	-
18	PCB	Control board *	230V 50/60Hz	YE80000100000
19	X1	Terminal board	-	YE61250040000
20	-	Terminal board	-	YE61253500000
21	X2	Terminal board	-	YE61250040000
22	-	Terminal board	-	YE61253500000
23	-	Terminal board	-	YE61250040000
24	-	Terminal board	-	YE61253500000
25	-	Terminal board	-	YE61250040000
26	-	Terminal board	-	YE61253500000
27	M1	Pump motor	400V 50/60Hz	-
28	M2	Compressor	400V 50/60Hz 2.57kW	-
29	M3	Fan motor	400V 50/60Hz 0.25kW	-
30	EH1	Compressor crankcase heater	230V 50/60Hz 45W	-
31	Y1	Solenoid valve**	230V 50/60Hz	-
32	Y2	Solenoid valve**	230V 50/60Hz	-

* means possible broken parts. ** means easy broken parts. Spare backup is suggested. Please confirm the version number of the manual before you order to ensure the stock

number and the parts are consistent.

2.3.6 Main Electrical Circuit (SIC-12A-R2) (400V)

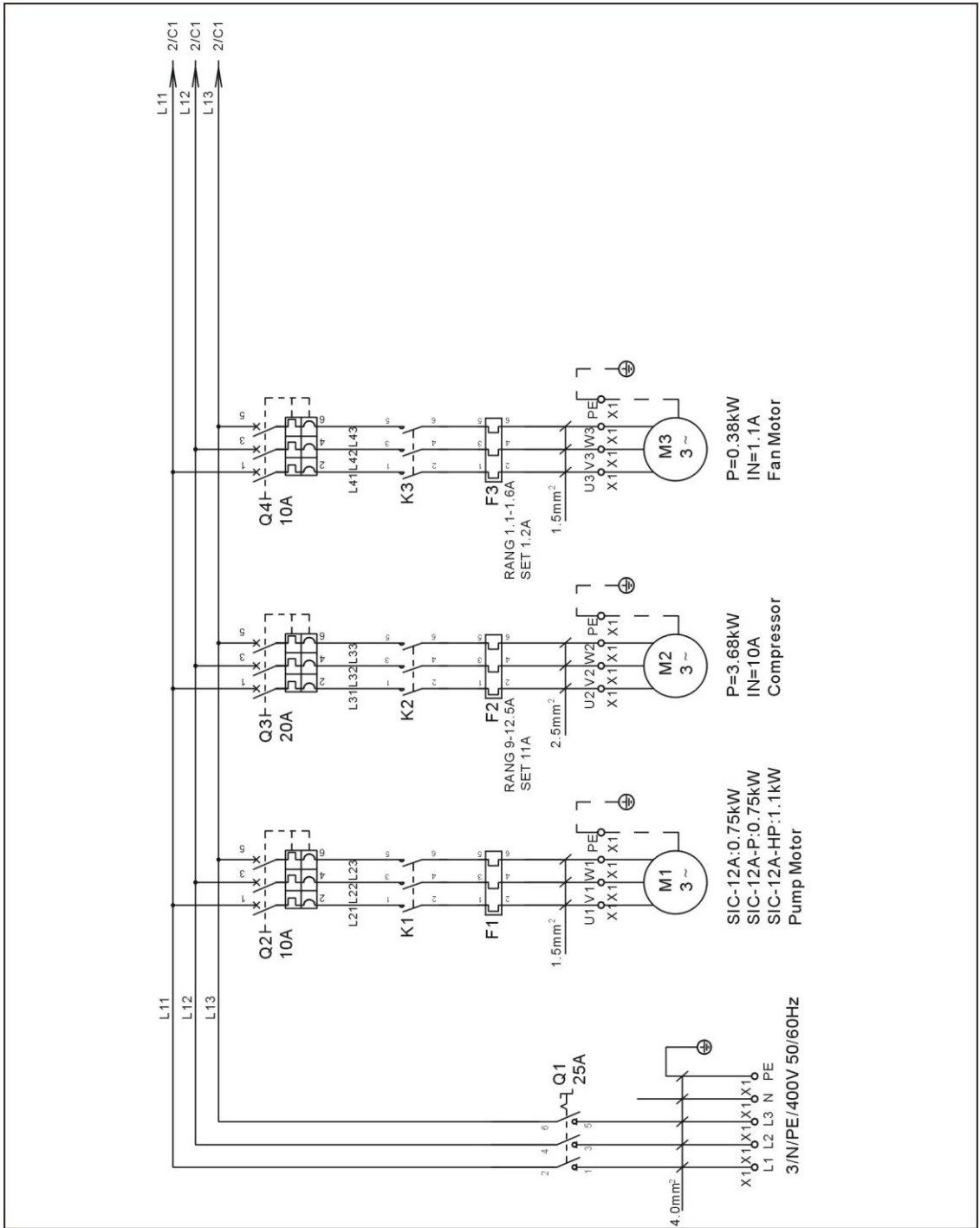

Picture 2-40: Main Electrical Circuit (SIC-12A-R2) (400V)

2.3.7 Control Circuit (SIC-12A-R2) (400V)

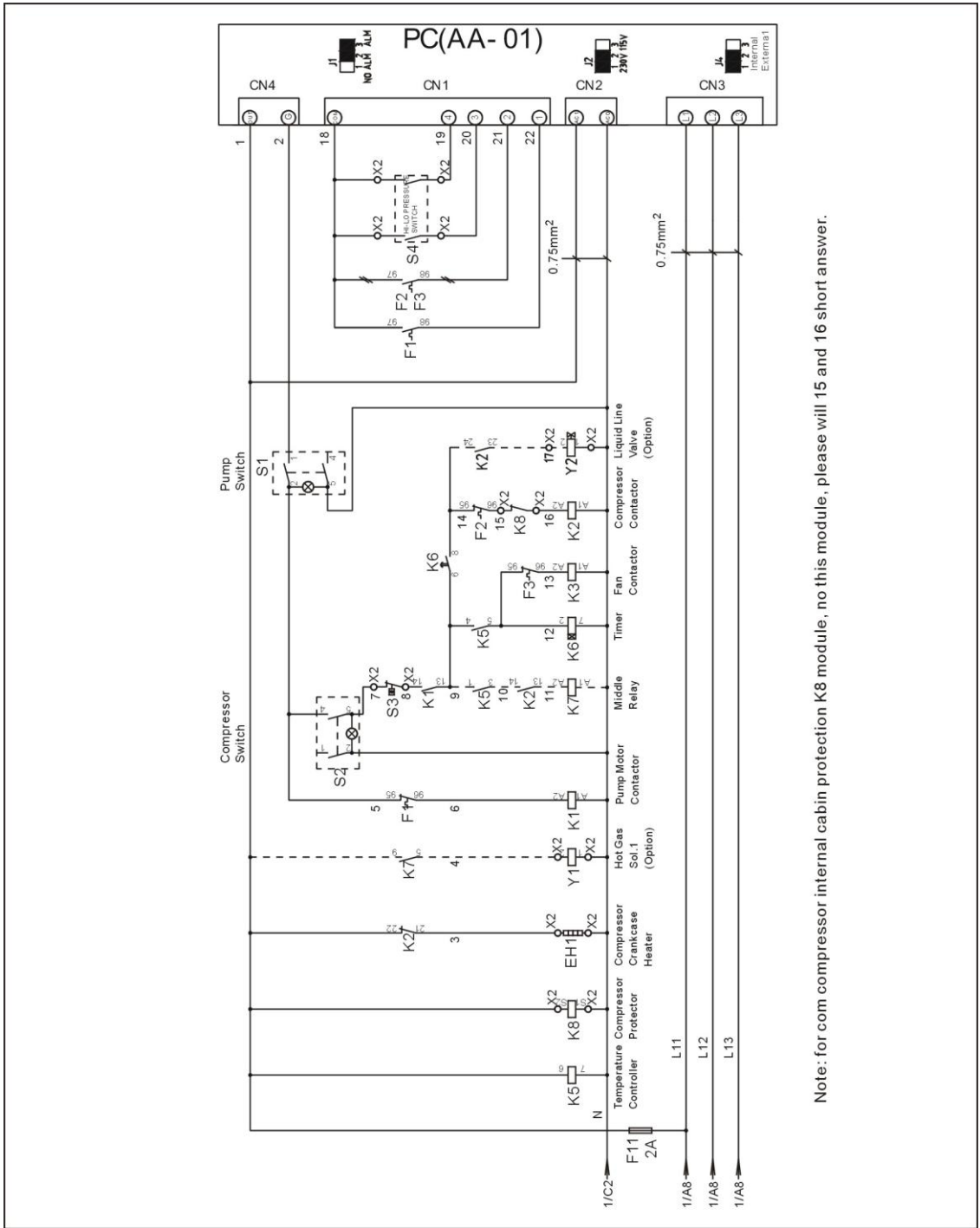

Note: for com compressor internal cabin protection K8 module, no this module, please will 15 and 16 short answer.

Picture 2-41: Control Circuit (SIC-12A-R2) (400V)

2.3.8 Electrical Components Layout (SIC-12A-R2) (400V)

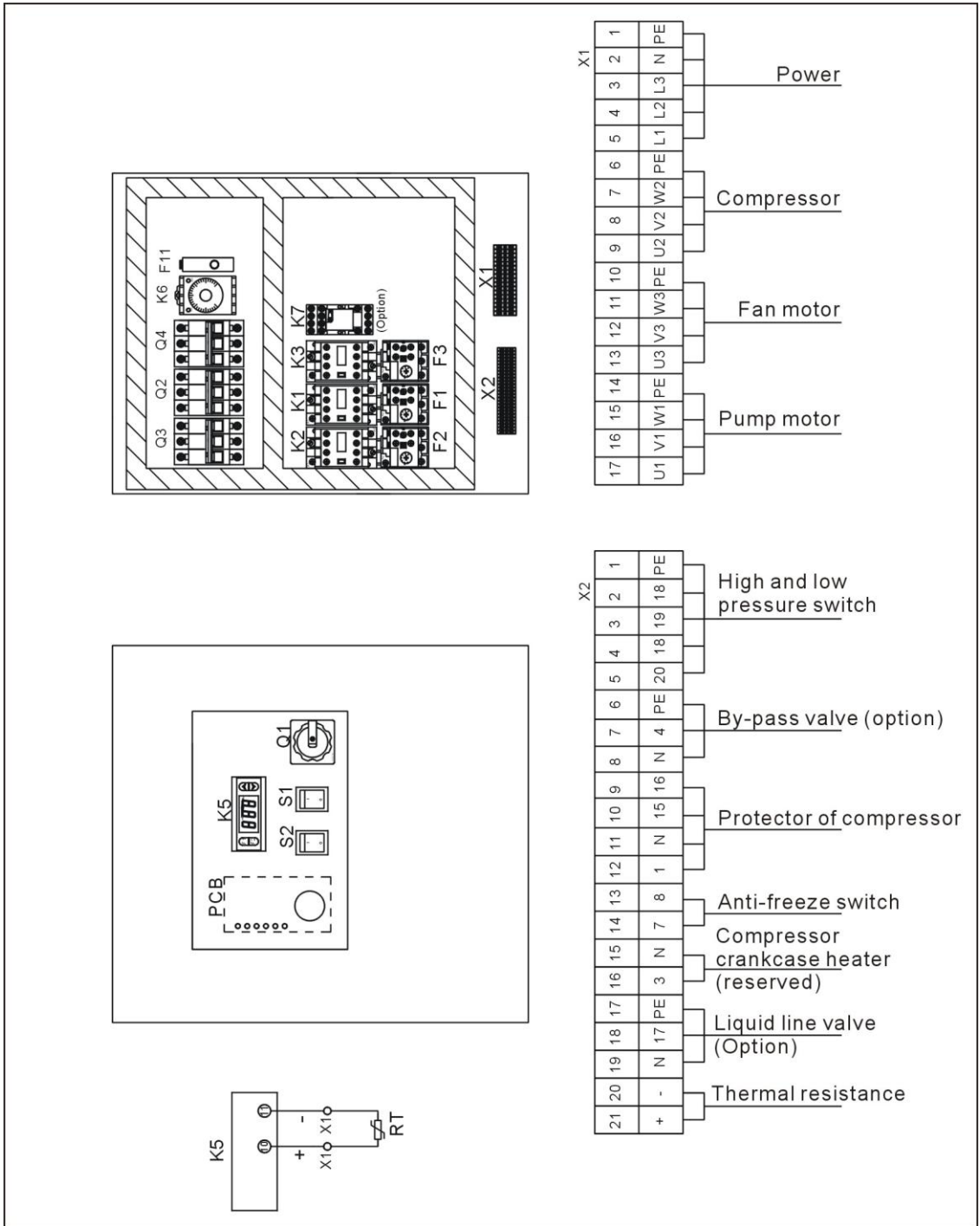

Picture 2-42: Electrical Components Layout (SIC-12A-R2) (400V)

2.3.9 Electrical Components List (SIC-12A-R2) (400V)

Table 2-31: Electrical Components List (SIC-12A-R2) (400V)

No.	Symbol	Name	Specificatons	Parts No.
1	Q1	Main switch	25A	YE10125250000
2	Q3	Circuit breaker *	20A	YE40602000000
3	Q2 Q4	Circuit breaker *	10A	YE40600300000
4	K1	Contactora *	220VAC 50/60Hz	-
5	K2	Contactora *	220VAC 50/60Hz	YE00601800100
6	-	Auciliary block	2NO+2NC	YE00691110000
7	K3	Contactora *	220VAC 50/60Hz	YE00601521000
8	K5	Temperature controller *	115~230VAC	YE85120200000
9	K6	Timer	3S-60M AC220V	YE86300300000
10	K7	Middle realy	AC220V	YE03270700000
11	F1	Overload relay *	-	-
12	F2	Overload relay *	9~12.5A	YE01169125000
13	F3	Overload relay *	1.1~1.6A	YE01160110000
14	F11	Fuse**	2A	YE41001000000
15	S1 S2	Control switch *	250V~10(5)A 4P WH	YE10210400000
16	S3	Anti-frozen switch *	-	-
17	S4	HI-LO pressure switch	-	-
18	PCB	Control board *	230V 50/60Hz	YE80000100000
19	X1	Terminal board	-	YE61250040000
20	-	Terminal board	-	YE61253500000
21	-	Terminal board	-	YE61400010000
22	-	Terminal board	-	YE61403510000
23	X2	Terminal board	-	YE61250040000
24	-	Terminal board	-	YE61253500000
25	-		-	YE61250040000
26	-		-	YE61253500000
27	-		-	YE61250040000
28	-		-	YE61253500000
29	M1	Pump motor	400V 50/60Hz	-
30	M2	Compressor	400V 50/60Hz 3.68kW	-
31	M3	Fan motor	400V 50/60Hz 0.38kW	-
32	EH1	Compressor crankcase heater	230V 50/60Hz 45W	-
33	Y1	Solenoid valve**	230V 50/60Hz	-
34	Y2	Solenoid valve**	230V 50/60Hz	-

* means possible broken parts. ** means easy broken parts. Spare backup is suggested. Please confirm the version number of the manual before you order to ensure the stock number and the parts are consistent.

2.3.10 Main Electrical Circuit (SIC-18A-R2) (400V)

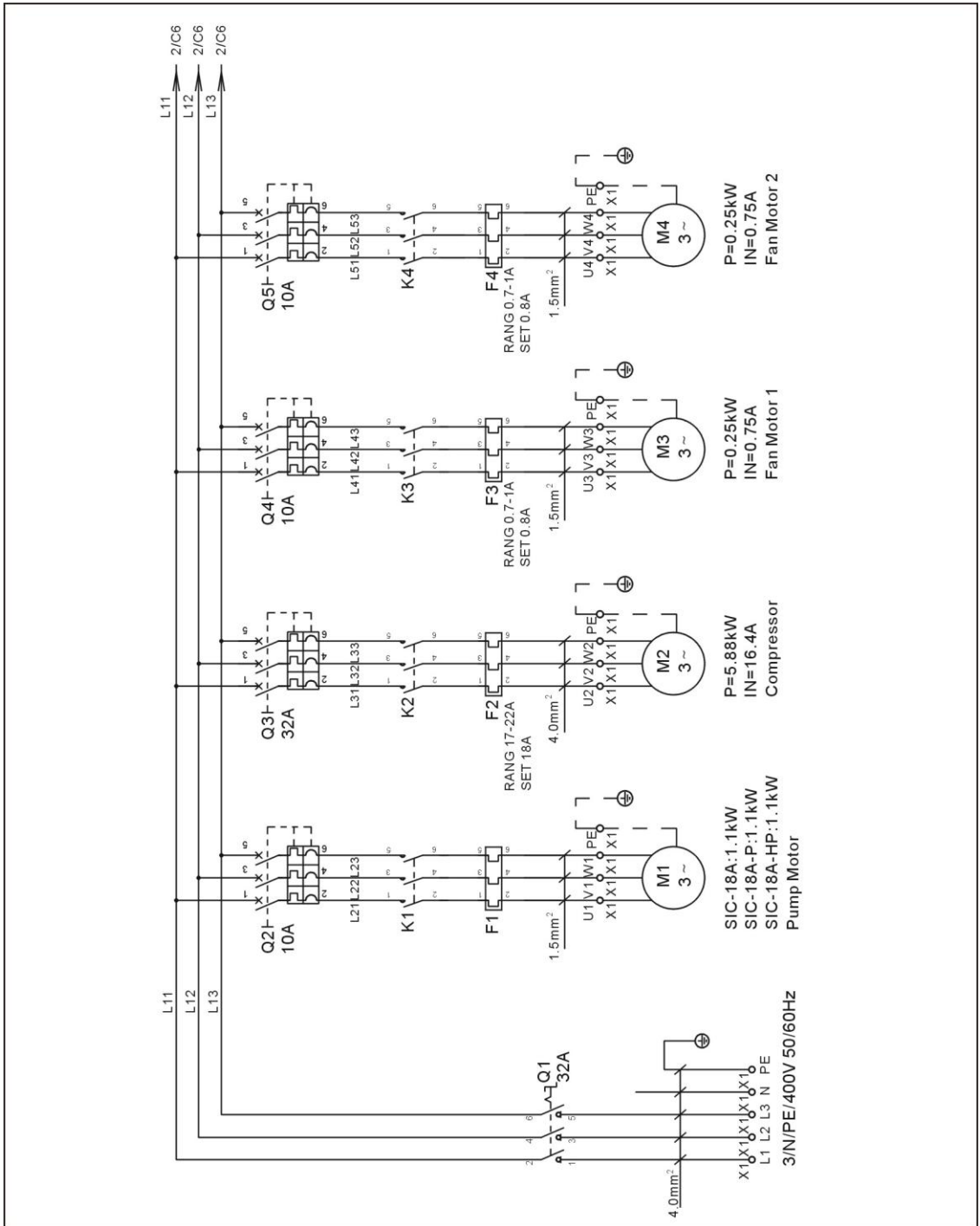

Picture 2-43: Main Electrical Circuit (SIC-18A-R2) (400V)

2.3.11 Control Circuit (SIC-18A-R2) (400V)

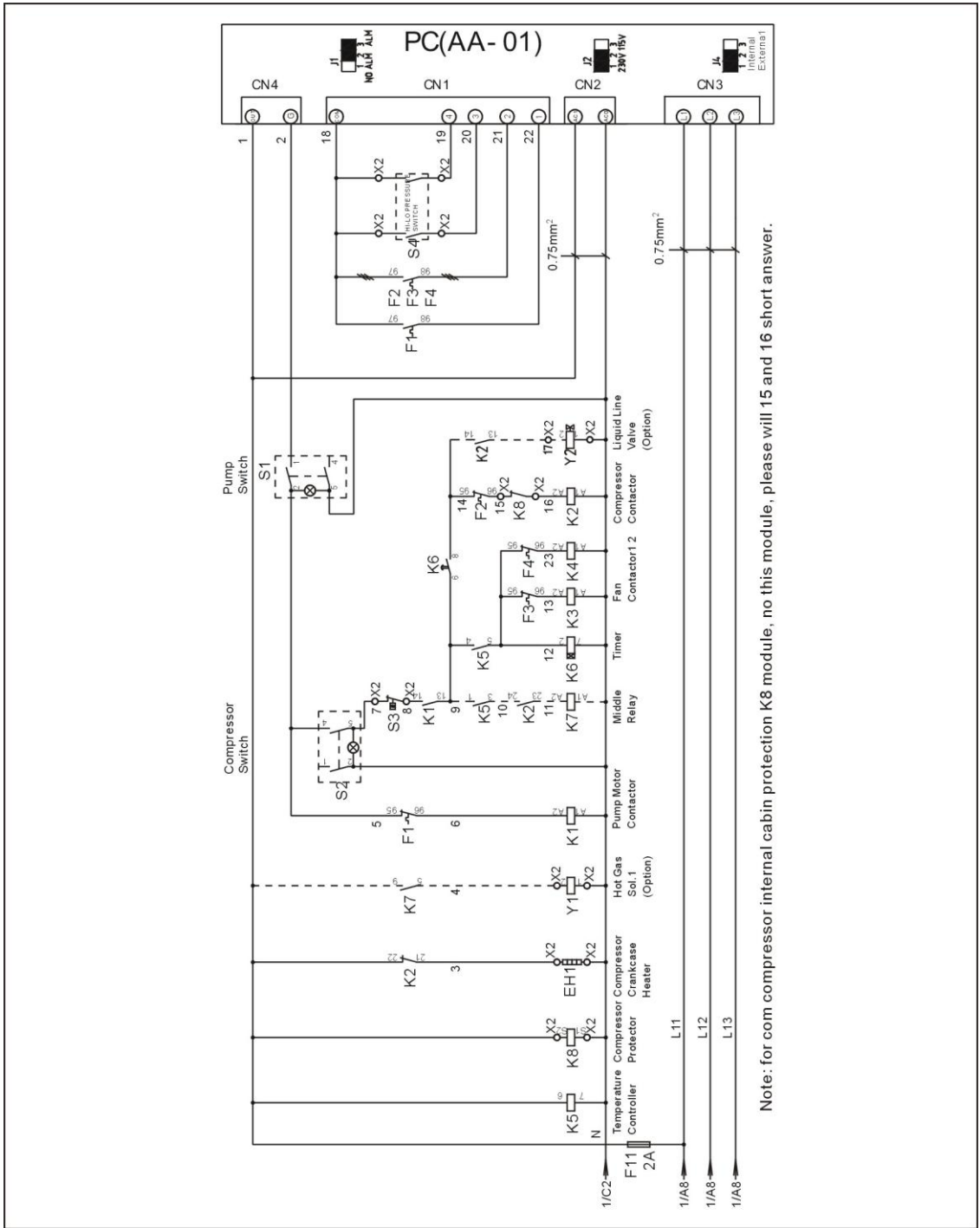

Note: for com compressor internal cabin protection K8 module, no this module, please will 15 and 16 short answer.

Picture 2-44: Control Circuit (SIC-18A-R2) (400V)

2.3.12 Electrical Components Layout (SIC-18A-R2) (400V)

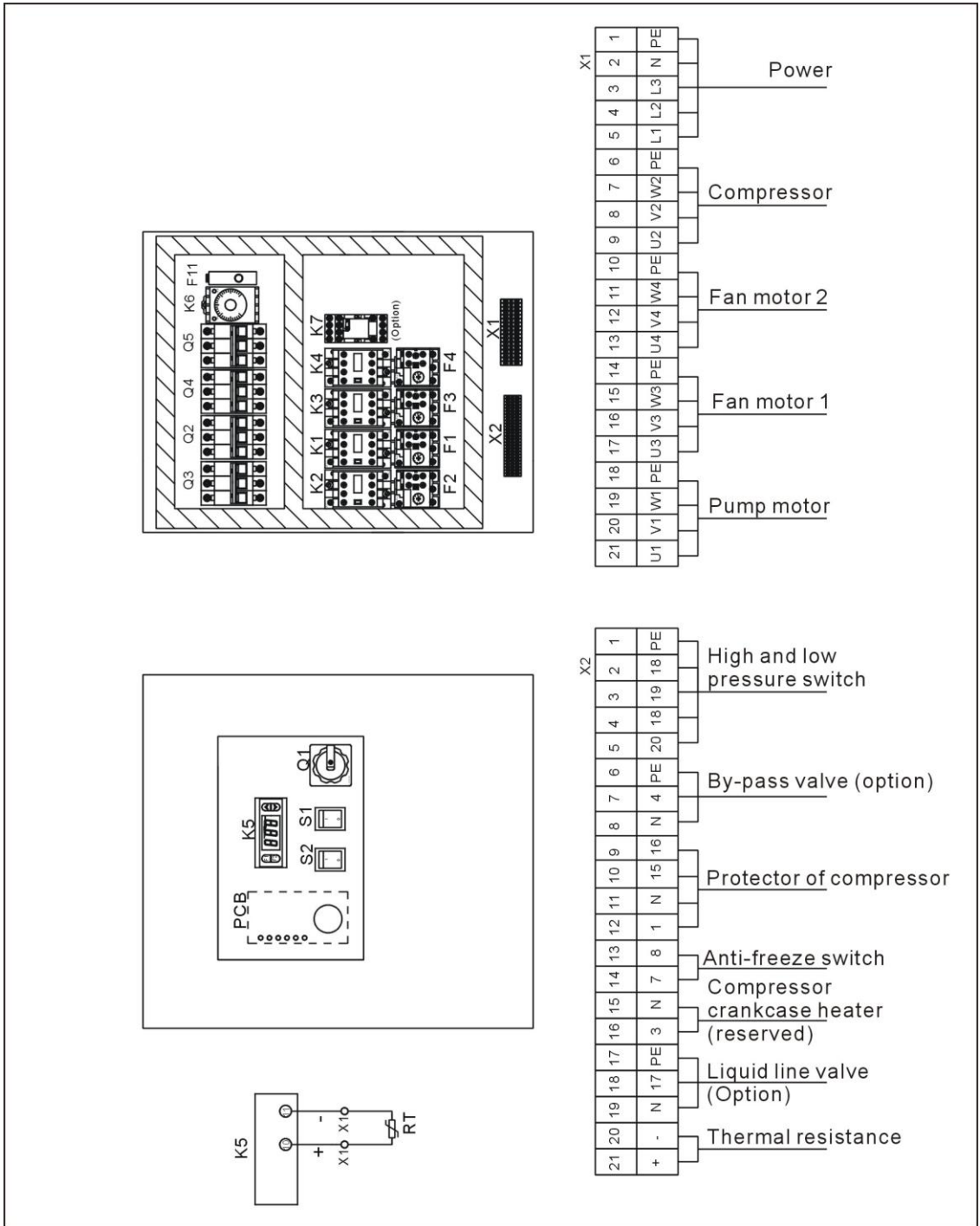

Picture 2-45: Electrical Components Layout (SIC-18A-R2) (400V)

2.3.13 Electrical Components List (SIC-18A-R2) (400V)

Table 2-32: Electrical Components List (SIC-18A-R2) (400V)

No.	Symbol	Name	Specificatons	Parts No.
1	Q1	Main switch	32A	YE10323200000
2	Q3	Circuit breaker *	32A	YE40603200000
3	Q2 Q4 Q5	Circuit breaker *	10A	YE40600300000
4	K1	Contactor *	220VAC 50/60Hz	-
5	K2	Contactor *	220VAC 50/60Hz	YE00602622000
6	-	Auxiliary block	1NO	YE00691110000
7	K3 K4	Contactor *	220VAC 50/60Hz	YE00601521000
8	K5	Temperature controller *	115~230VAC	YE85120200000
9	K6	Timer	3S-60M AC220V	YE86300300000
10	K7	Middle realy	AC220V	YE03270700000
11	F1	Overload relay *	-	-
12	F2	Overload relay *	17~22A	YE01260170000
13	F3 F4	Overload relay *	0.7~1A	YE01160700000
14	F11	Fuse**	2A	YE41001000000
15	S1 S2	Control switch *	250V~10(5)A 4P WH	YE10210400000
16	S3	Anti-frozen switch *	-	-
17	S4	HI-LO pressure switch	-	-
18	PCB	Control board *	230V 50/60Hz	YE80000100000
19	X1	Terminal board	-	YE61250040000
20	-	Terminal board	-	YE61253500000
21	-	Terminal board	-	YE61400010000
22	-	Terminal board	-	YE61403510000
23	X2	Terminal board	-	YE61250040000
24	-	Terminal board	-	YE61253500000
25	-	Terminal board	-	YE61250040000
26	-	Terminal board	-	YE61253500000
27	-	Terminal board	-	YE61250040000
28	-	Terminal board	-	YE61253500000
29	M1	Pump motor	400V 50/60Hz	-
30	M2	Compressor	400V 50/60Hz 5.88kW	-
31	M3 M4	Fan motor	400V 50/60Hz 0.25kW	-
32	EH1	Compressor crankcase heater	230V 50/60Hz 45W	-
33	Y1	Solenoid valve**	230V 50/60Hz	-
34	Y2	Solenoid valve**	230V 50/60Hz	-

* means possible broken parts. ** means easy broken parts. Spare backup is suggested. Please confirm the version number of the manual before you order to ensure the stock number and the parts are consistent.

2.3.14 Main Electrical Circuit (SIC-24A-R2) (400V)

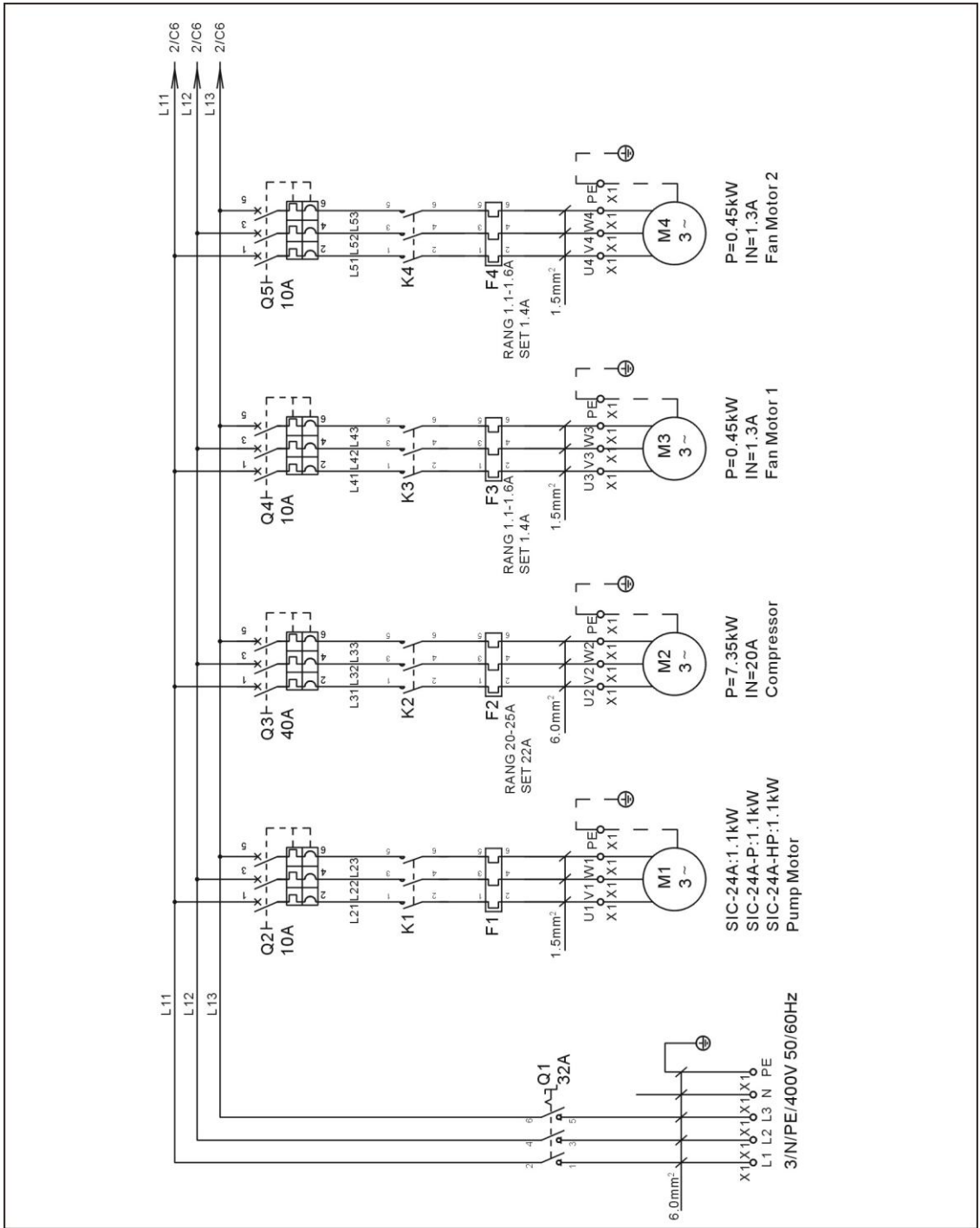

Picture 2-46: Main Electrical Circuit (SIC-24A-R2) (400V)

2.3.15 Control Circuit (SIC-24A-R2) (400V)

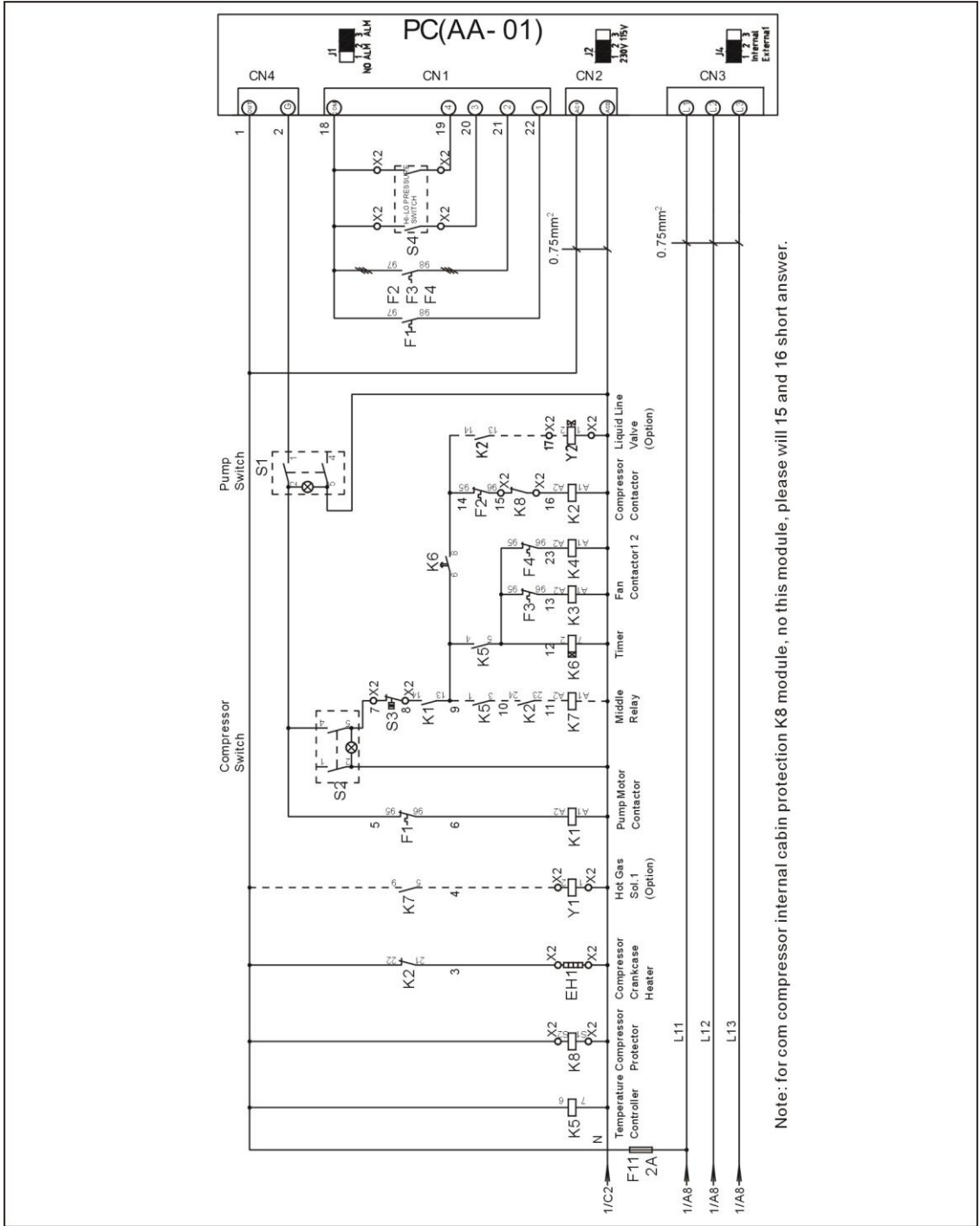

Picture 2-47: Control Circuit (SIC-24A-R2) (400V)

2.3.17 Electrical Components List (SIC-24A-R2) (400V)

Table 2-33: Electrical Components List (SIC-24A-R2) (400V)

No.	Symbol	Name	Specificatons	Parts No.
1	Q1	Main switch	32A	YE10323200000
2	Q3	Circuit breaker *	40A	YE40604000000
3	Q2 Q4 Q5	Circuit breaker *	10A	YE40600300000
4	K1	Contactor *	220VAC 50/60Hz	-
5	K2	Contactor *	220VAC 50/60Hz	YE00602722000
6	-	Auxiliary block	1NO	YE00691110000
7	K3 K4	Contactor *	220VAC 50/60Hz	YE00601521000
8	K5	Temperature controller *	115~230VAC	YE85120200000
9	K6	Timer	3S-60M AC220V	YE86300300000
10	K7	Middle realy	AC220V	YE03270700000
11	F1	Overload relay *	-	-
12	F2	Overload relay *	20~25A	YE01260200000
13	F3 F4	Overload relay *	1.1~1.6A	YE01160110000
14	F11	Fuse**	2A	YE41001000000
15	S1 S2	Control switch *	250V~10(5)A 4P WH	YE10210400000
16	S3	Anti-frozen switch *	-	-
17	S4	HI-LO pressure switch	-	-
18	PCB	Control board *	230V 50/60Hz	YE80000100000
19	X1	Terminal board	-	YE61250040000
20	-	Terminal board	-	YE61253500000
21	-	Terminal board	-	YE61060000000
22	-	Terminal board	-	YE61063500000
23	X2	Terminal board	-	YE61250040000
24	-	Terminal board	-	YE61253500000
25	-	Terminal board	-	YE61250040000
26	-	Terminal board	-	YE61253500000
27	-	Terminal board	-	YE61250040000
28	-	Terminal board	-	YE61253500000
29	M1	Pump motor	400V 50/60Hz	-
30	M2	Compressor	400V 50/60Hz 7.35kW	-
31	M3 M4	Fan motor	400V 50/60Hz 0.45kW	-
32	EH1	Compressor crankcase heater	230V 50/60Hz 45W	-
33	Y1	Solenoid valve**	230V 50/60Hz	-
34	Y2	Solenoid valve**	230V 50/60Hz	-

* means possible broken parts. ** means easy broken parts. Spare backup is suggested. Please confirm the version number of the manual before you order to ensure the stock number and the parts are consistent.

2.3.18 Main Electrical Circuit (SIC-28A-R2) (400V)

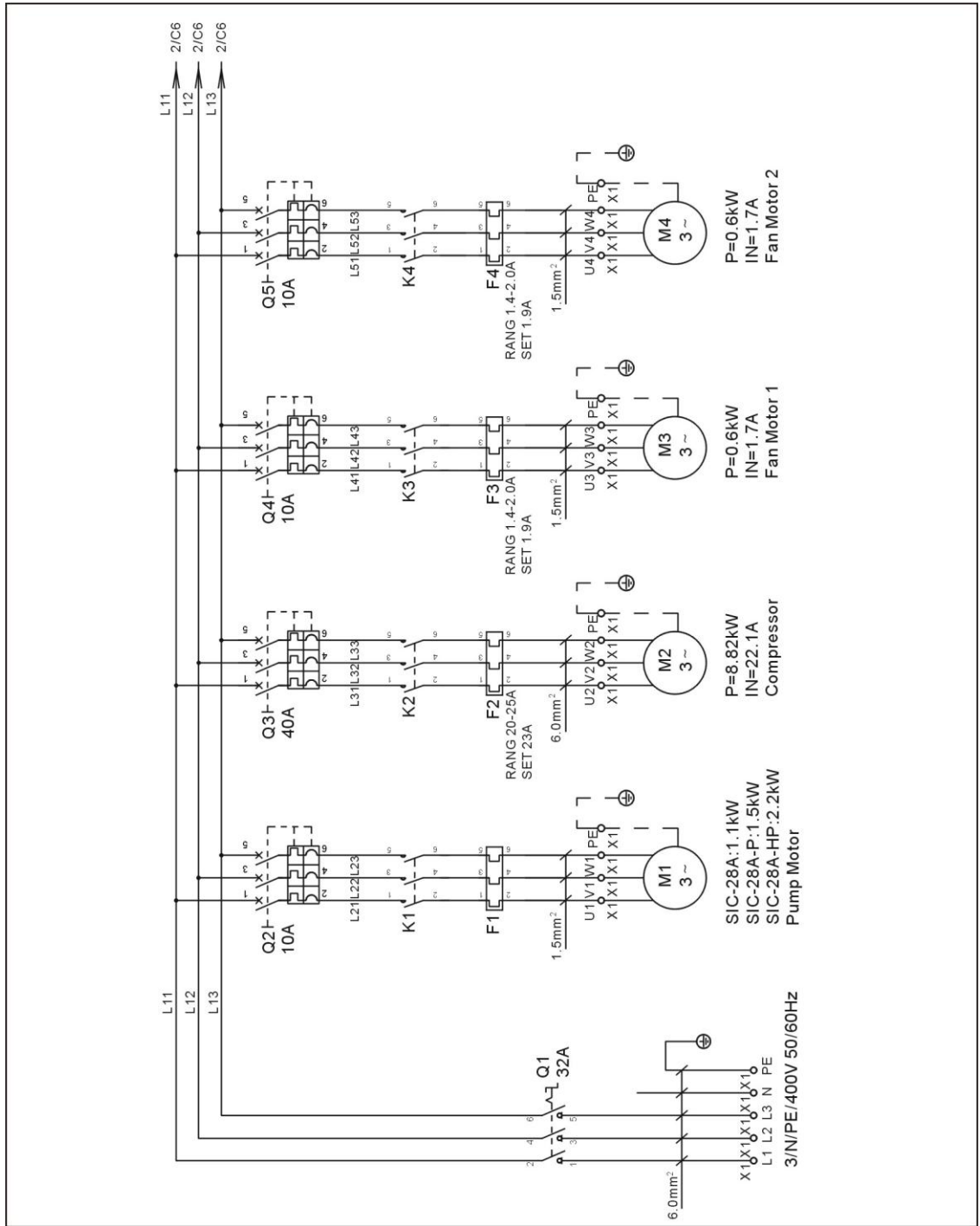

Picture 2-49: Main Electrical Circuit (SIC-28A-R2) (400V)

2.3.19 Control Circuit (SIC-28A-R2) (400V)

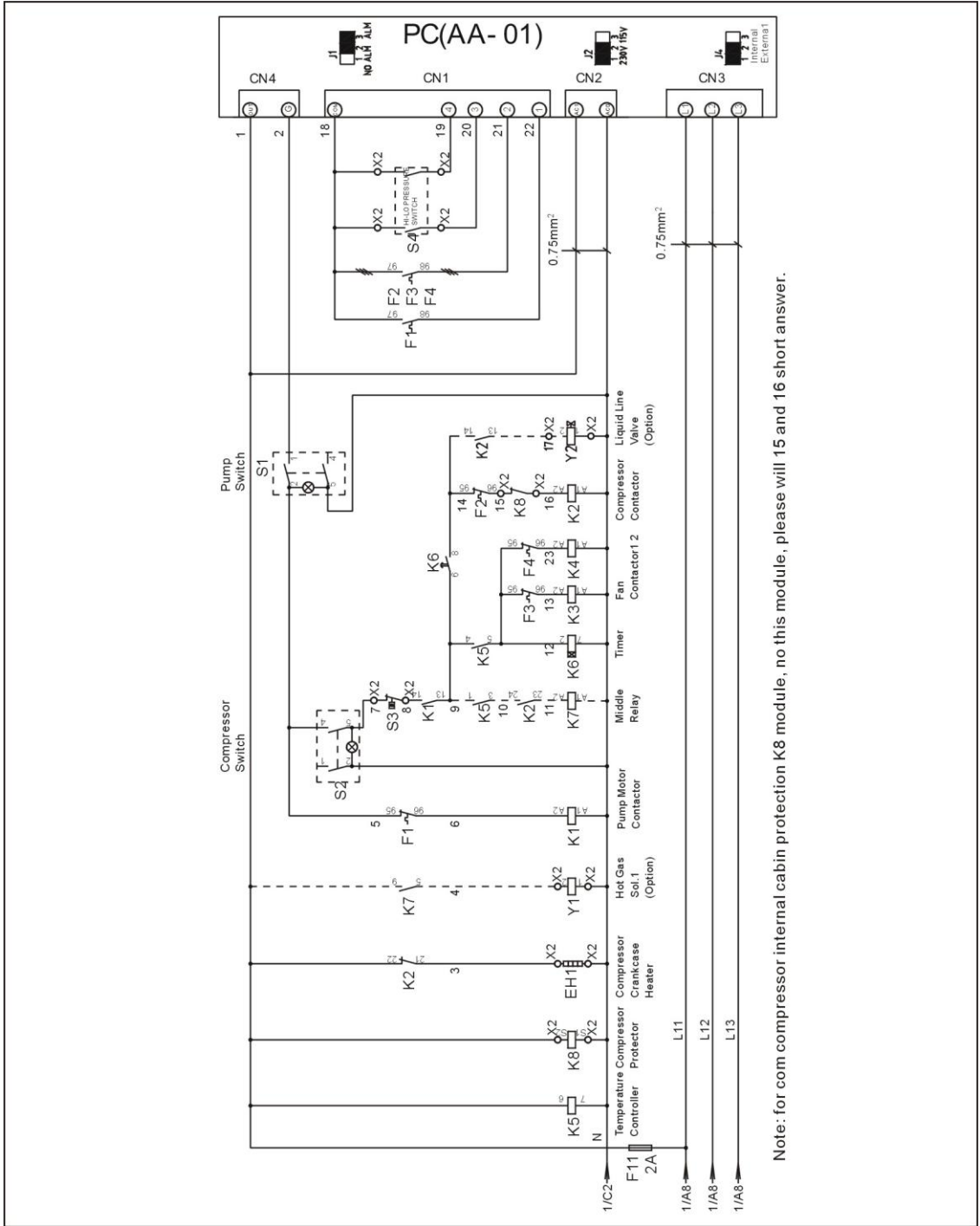

Picture 2-50: Control Circuit (SIC-28A-R2) (400V)

2.3.20 Electrical Components Layout (SIC-28A-R2) (400V)

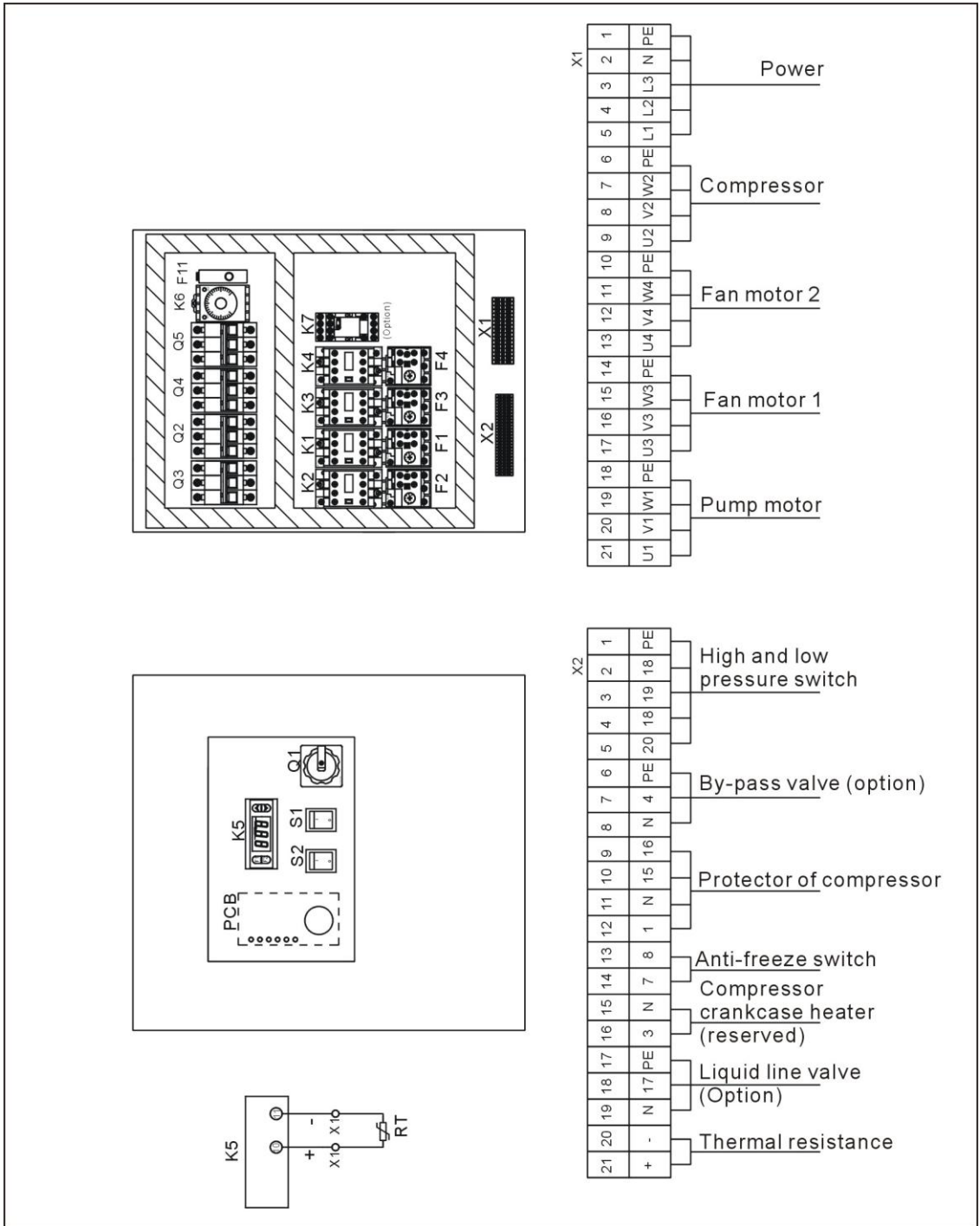

Picture 2-51: Electrical Components Layout (SIC-28A-R2) (400V)

2.3.21 Electrical Components List (SIC-28A-R2) (400V)

Table 2-34: Electrical Components List (SIC-28A-R2) (400V)

No.	Symbol	Name	Specificatons	Parts No.
1	Q1	Main switch	32A	YE10323200000
2	Q3	Circuit breaker *	40A	YE40604000000
3	Q2 Q5	Q4 Circuit breaker *	10A	YE40600300000
4	K1	Contactora *	220VAC 50/60Hz	-
5	K2	Contactora *	220VAC 50/60Hz	YE00602722000
6	-	Auxiliary block	1NO	YE00691110000
7	K3 K4	Contactora *	220VAC 50/60Hz	YE00601521000
8	K5	Temperature controller *	115~230VAC	YE85120200000
9	K6	Timer	3S-60M AC220V	YE86300300000
10	K7	Middle realy	AC220V	YE03270700000
11	F1	Overload relay *	-	-
12	F2	Overload relay *	20~25A	YE01260200000
13	F3 F4	Overload relay *	1.4~2.0A	YE01160140000
14	F11	Fuse**	2A	YE41001000000
15	S1 S2	Control switch *	250V~10(5)A 4P WH	YE10210400000
16	S3	Anti-frozen switch *	-	-
17	S4	HI-LO pressure switch	-	-
18	PCB	Control board *	230V 50/60Hz	YE80000100000
19	X1	Terminal board	-	YE61250040000
20	-	Terminal board	-	YE61253500000
21	-	Terminal board	-	YE61060000000
22	-	Terminal board	-	YE61063500000
23	X2	Terminal board	-	YE61250040000
24	-	Terminal board	-	YE61253500000
25	-	Terminal board	-	YE61250040000
26	-	Terminal board	-	YE61253500000
27	-	Terminal board	-	YE61250040000
28	-	Terminal board	-	YE61253500000
29	M1	Pump motor	400V 50/60Hz	-
30	M2	Compressor	400V 50/60Hz 8.82kW	-
31	M3 M4	Fan motor	400V 50/60Hz 0.6kW	-
32	EH1	Compressor crankcase heater	230V 50/60Hz 45W	-
33	Y1	Solenoid valve**	230V 50/60Hz	-
34	Y2	Solenoid valve**	230V 50/60Hz	-

* means possible broken parts. ** means easy broken parts. Spare backup is suggested. Please confirm the version number of the manual before you order to ensure the stock

number and the parts are consistent.

2.3.22 Main Electrical Circuit (SIC-38A-R2) (400V)

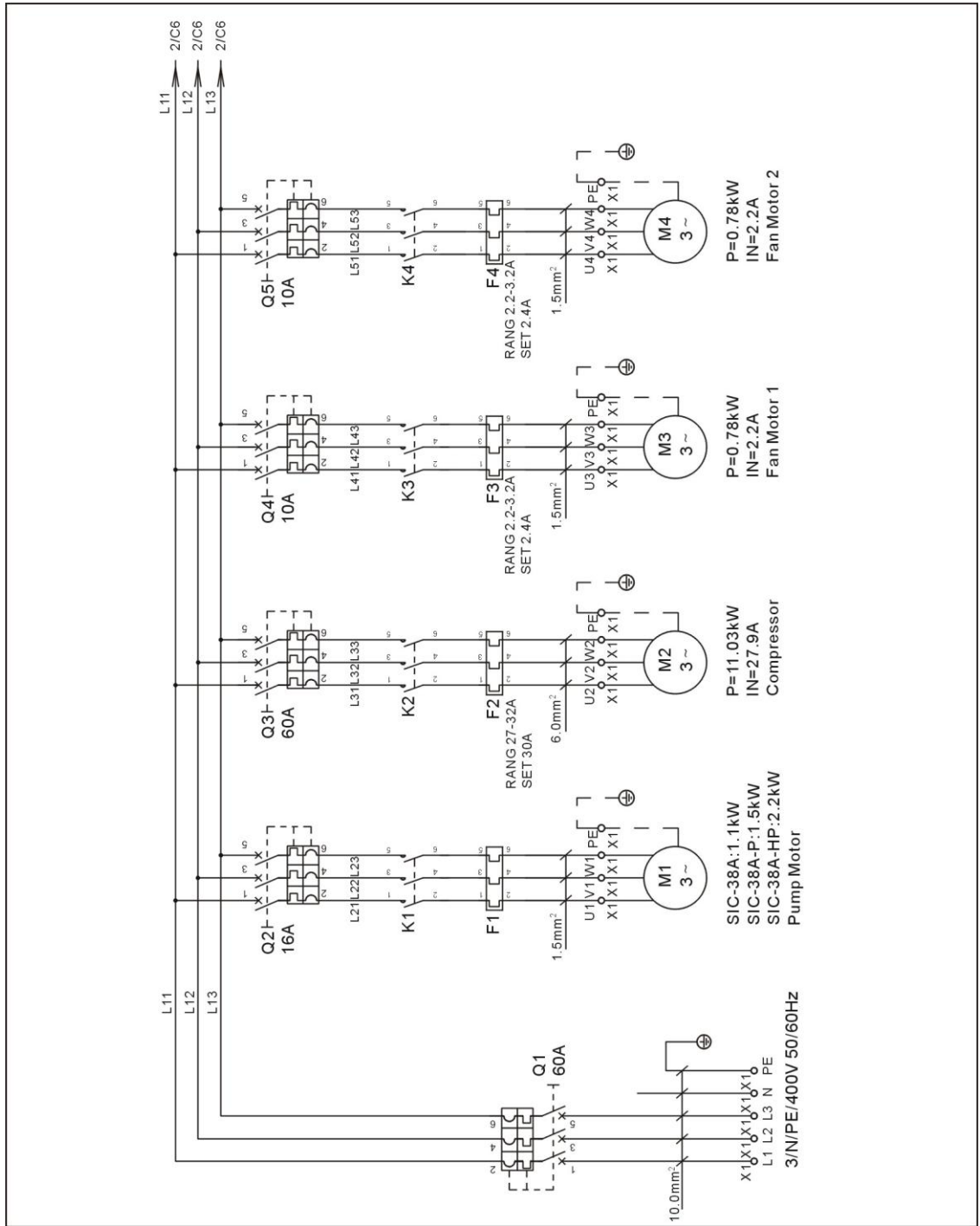

Picture 2-52: Main Electrical Circuit (SIC-38A-R2) (400V)

2.3.23 Control Circuit (SIC-38A-R2) (400V)

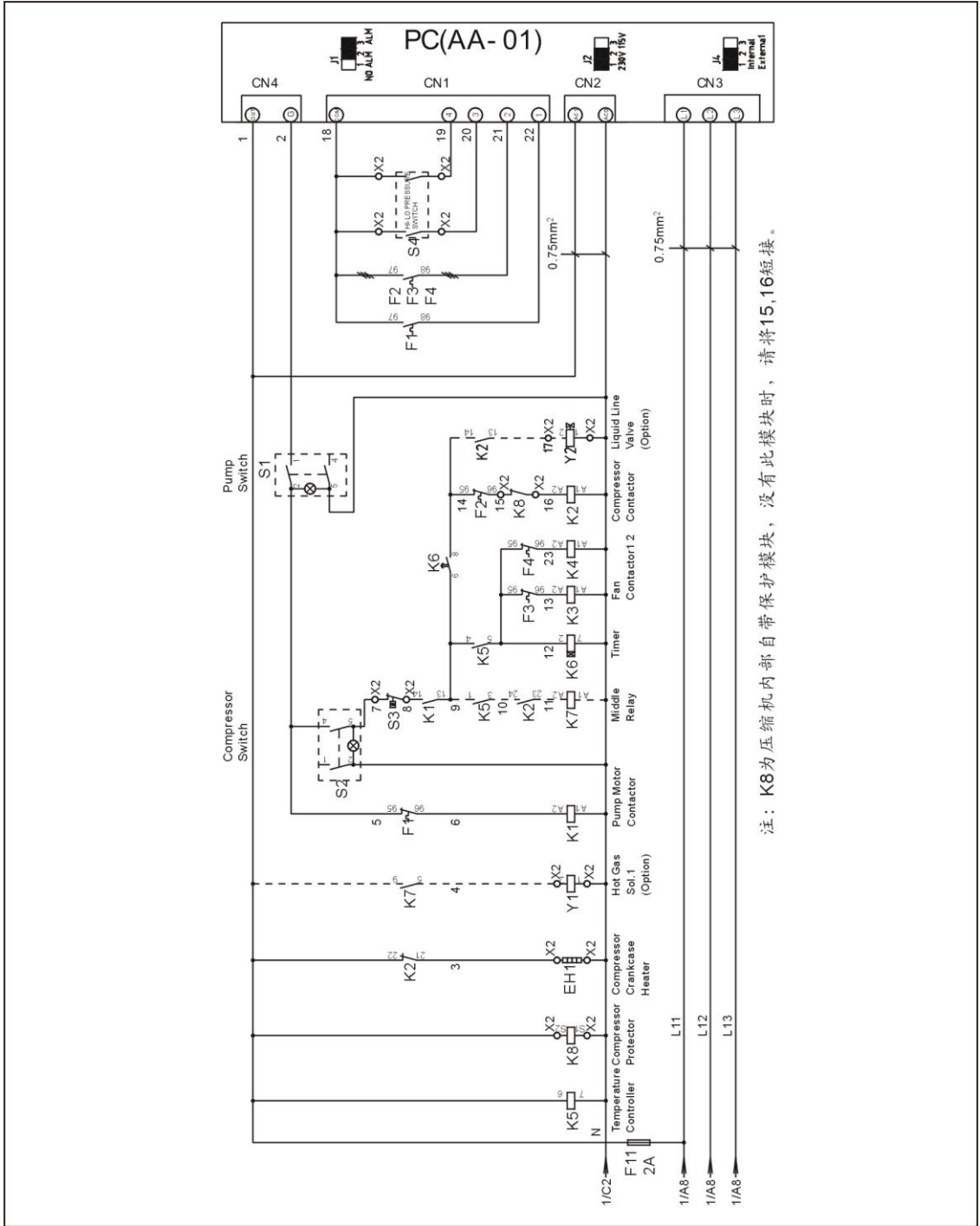

注：K8为压缩机内部自带保护模块，没有此模块时，请将15,16短接。

Picture 2-53: Control Circuit (SIC-38A-R2) (400V)

2.3.24 Electrical Components Layout (SIC-38A-R2) (400V)

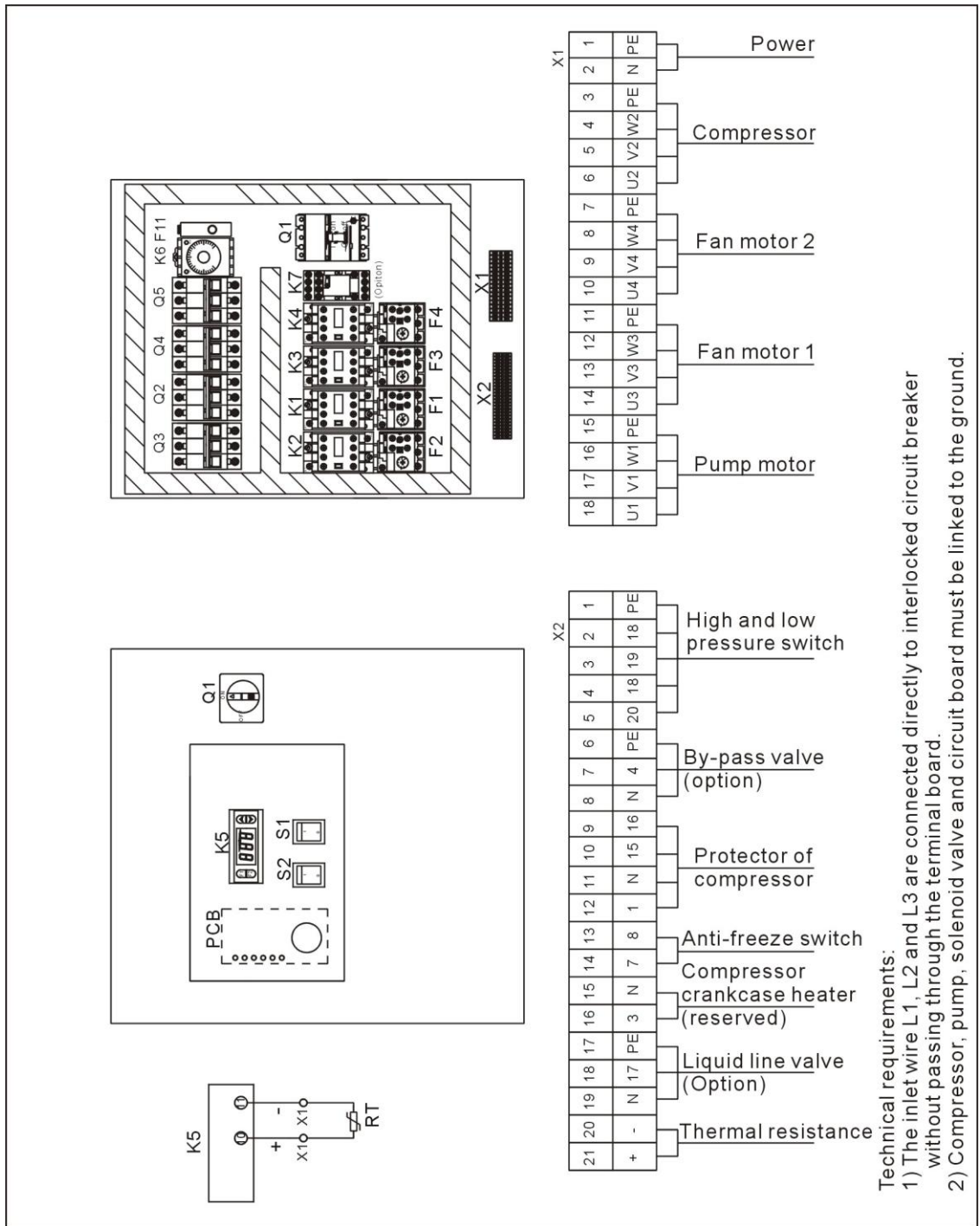

Picture 2-54: Electrical Components Layout (SIC-38A-R2) (400V)

2.3.25 Electrical Components List (SIC-38A-R2) (400V)

Table 2-35: Electrical Components List (SIC-38A-R2) (400V)

No.	Symbol	Name	Specificatons	Parts No.
1	Q1	Circuit breaker *	60A	YE40606000000
2	Q3	Circuit breaker *	60A	YE40606000000
3	Q2	Circuit breaker *	16A	YE40600300000
4	Q4 Q5	Circuit breaker *	10A	YE40600300000
5	K1	Contacto ^r *	220VAC 50/60Hz	-
6	K2	Contacto ^r *	220VAC 50/60Hz	YE00602822000
7	-	Auxiliary block	1NO	YE00691110000
8	K3 K4	Contacto ^r *	220VAC 50/60Hz	YE00601521000
9	K5	Temperature controller *	115~230VAC	YE85120200000
10	K6	Timer	3S-60M AC220V	YE86300300000
11	K7	Middle realy	AC220V	YE03270700000
12	F1	Overload relay *	-	-
13	F2	Overload relay *	27~32A	YE01260200000
14	F3 F4	Overload relay *	2.2~3.2A	YE01160220000
15	F11	Fuse**	2A	YE41001000000
16	S1 S2	Control switch *	250V~10(5)A 4P WH	YE10210400000
17	S3	Anti-frozen switch *	-	-
18	S4	HI-LO pressure switch	-	-
19	PCB	Control board *	230V 50/60Hz	YE80000100000
20	X1	Terminal board	-	YE61250040000
21	-	Terminal board	-	YE61253500000
22	-	Terminal board	-	YE61060000000
23	-	Terminal board	-	YE61063500000
24	-	Terminal board	-	YE61100000000
25	-	Terminal board	-	YE61103500000
26	X2	Terminal board	-	YE61250040000
27	-	Terminal board	-	YE61253500000
28	-	Terminal board	-	YE61250040000
29	-	Terminal board	-	YE61253500000
30	-	Terminal board	-	YE61250040000
31	-	Terminal board	-	YE61253500000
32	M1	Pump motor	400V 50/60Hz	-
33	M2	Compressor	400V 50/60Hz	-

No.	Symbol	Name	Specificatons	Parts No.
34	M3 M4	Fan motor	400V 50/60Hz 0.78kW	-
35	EH1	Compressor crankcase heater	230V 50/60Hz 45W	-
36	Y1	Solenoid valve**	230V 50/60Hz	-
37	Y2	Solenoid valve**	230V 50/60Hz	-

* means possible broken parts. ** means easy broken parts. Spare backup is suggested. Please confirm the version number of the manual before you order to ensure the stock number and the parts are consistent.

2.3.26 Main Electrical Circuit (SIC-48A-R2) (400V)

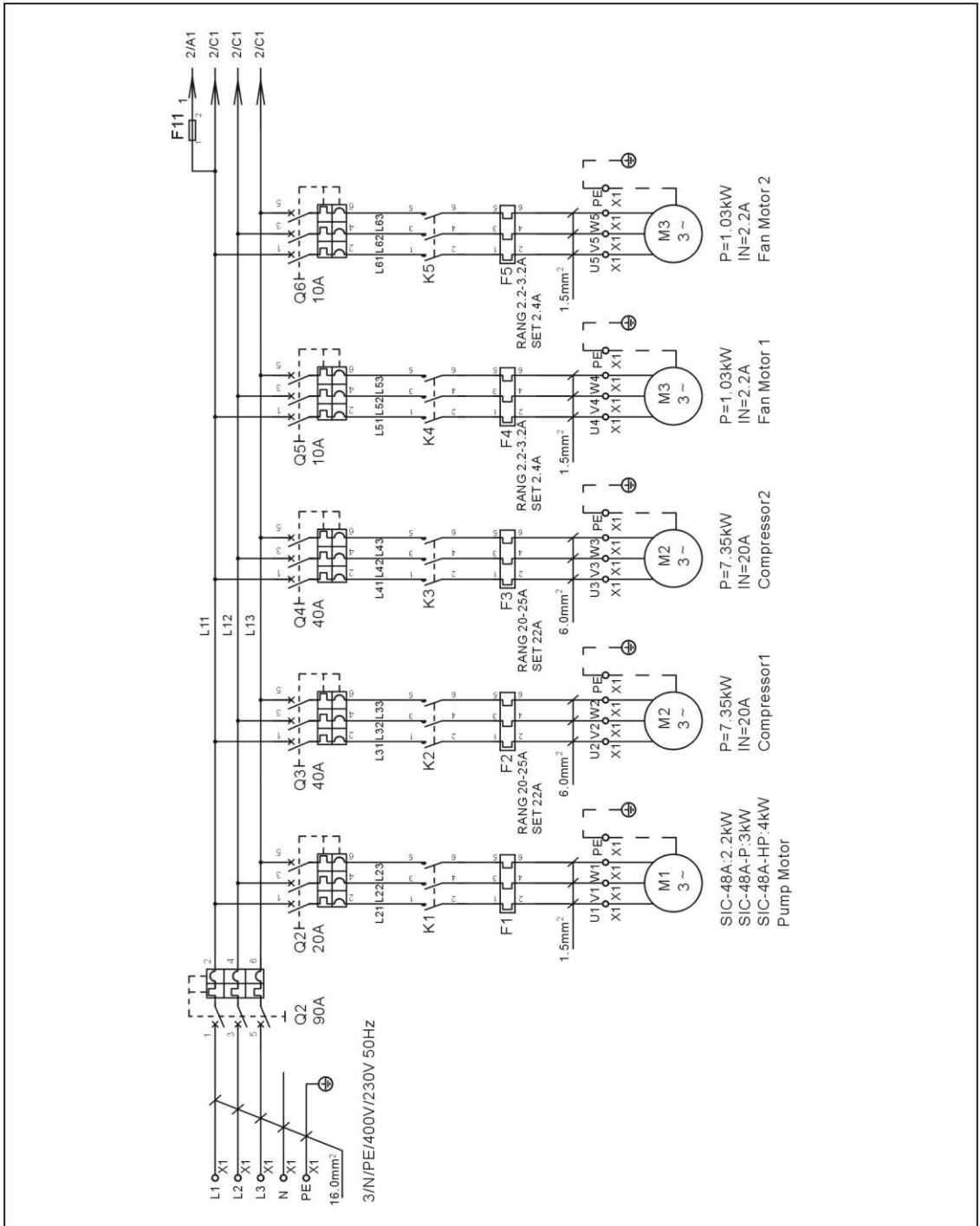

Picture 2-55: Main Electrical Circuit (SIC-48A-R2) (400V)

2.3.28 Electrical Components Layout (SIC-48A-R2) (400V)

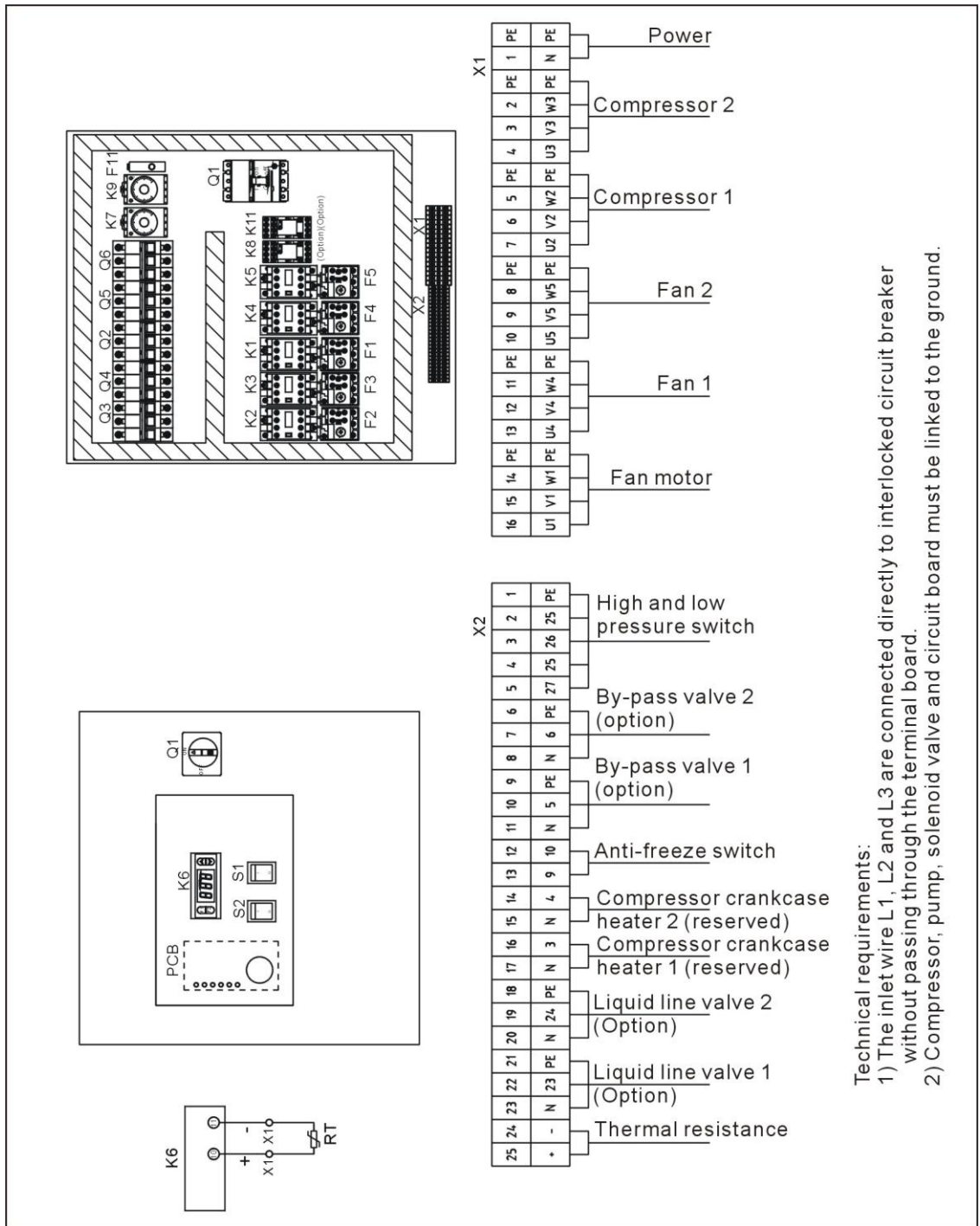

Picture 2-57: Electrical Components Layout (SIC-48A-R2) (400V)

2.3.29 Electrical Components List (SIC-48A-R2) (400V)

Table 2-36: Electrical Components List (SIC-48A-R2) (400V)

No.	Symbol	Name	Specificatons	Parts No.
1	Q1	Circuit breaker *	90A	YE41109000000
2	Q2	Circuit breaker *	20A	YE40602000000
3	Q3 Q4	Circuit breaker *	40A	YE40604000000
4	Q4 Q5	Circuit breaker *	10A	YE40600300000
5	K1	Contacto ^r *	220VAC 50/60Hz	-
6	K2 K3	Contacto ^r *	220VAC 50/60Hz	YE00602722000
7	-	Auxiliary block	2NO+2NC	YE00691100000
8	K4 K5	Contacto ^r *	220VAC 50/60Hz	YE00601521000
9	K6	Temperature controller *	115~230VAC	YE85120200000
10	K7 K9	Timer	3S-60M AC220V	YE86300300000
11	K8 K11	Middle realy	AC220V	YE03270700000
12	F1	Overload relay *	-	-
13	F2 F3	Overload relay *	20~25A	YE01260200000
14	F4 F5	Overload relay *	2.2~3.2A	YE01160220000
15	F11	Fuse**	2A	YE41001000000
16	S1 S2	Control switch *	250V~10(5)A 4P WH	YE10210400000
17	S3	Anti-frozen switch *	-	-
18	S4	HI-LO pressure switch	-	-
19	PCB	Control board *	230V 50/60Hz	YE80000100000
20	X1	Terminal board	-	YE61250040000
21	-	Terminal board	-	YE61253500000
22	-	Terminal board	-	YE61060000000
23	-	Terminal board	-	YE61063500000
24	-	Terminal board	-	YE61160000000
25	-	Terminal board	-	YE61163500000
26	X2	Terminal board	-	YE61250040000
27	-	Terminal board	-	YE61253500000
28	-	Terminal board	-	YE61250040000
29	-	Terminal board	-	YE61253500000
30	-	Terminal board	-	YE61250040000
31	-	Terminal board	-	YE61253500000
32	M1	Pump motor	400V 50/60Hz	-
33	M2 M3	Compressor	400V 50/60Hz 7.35kW	-

34	M4 M5	Fan motor	400V 50/60Hz 1.03kW	-
No.	Symbol	Name	Specificatons	Parts No.
35	EH1	Compressor crankcase heater	230V 50/60Hz	-
36	Y1 Y2	Solenoid valve**	230V 50/60Hz	-
37	Y3 Y4	Solenoid valve**	230V 50/60Hz	-

* means possible broken parts. ** means easy broken parts. Spare backup is suggested. Please confirm the version number of the manual before you order to ensure the stock number and the parts are consistent.

2.3.31 Control Circuit (SIC-58A-R2) (400V)

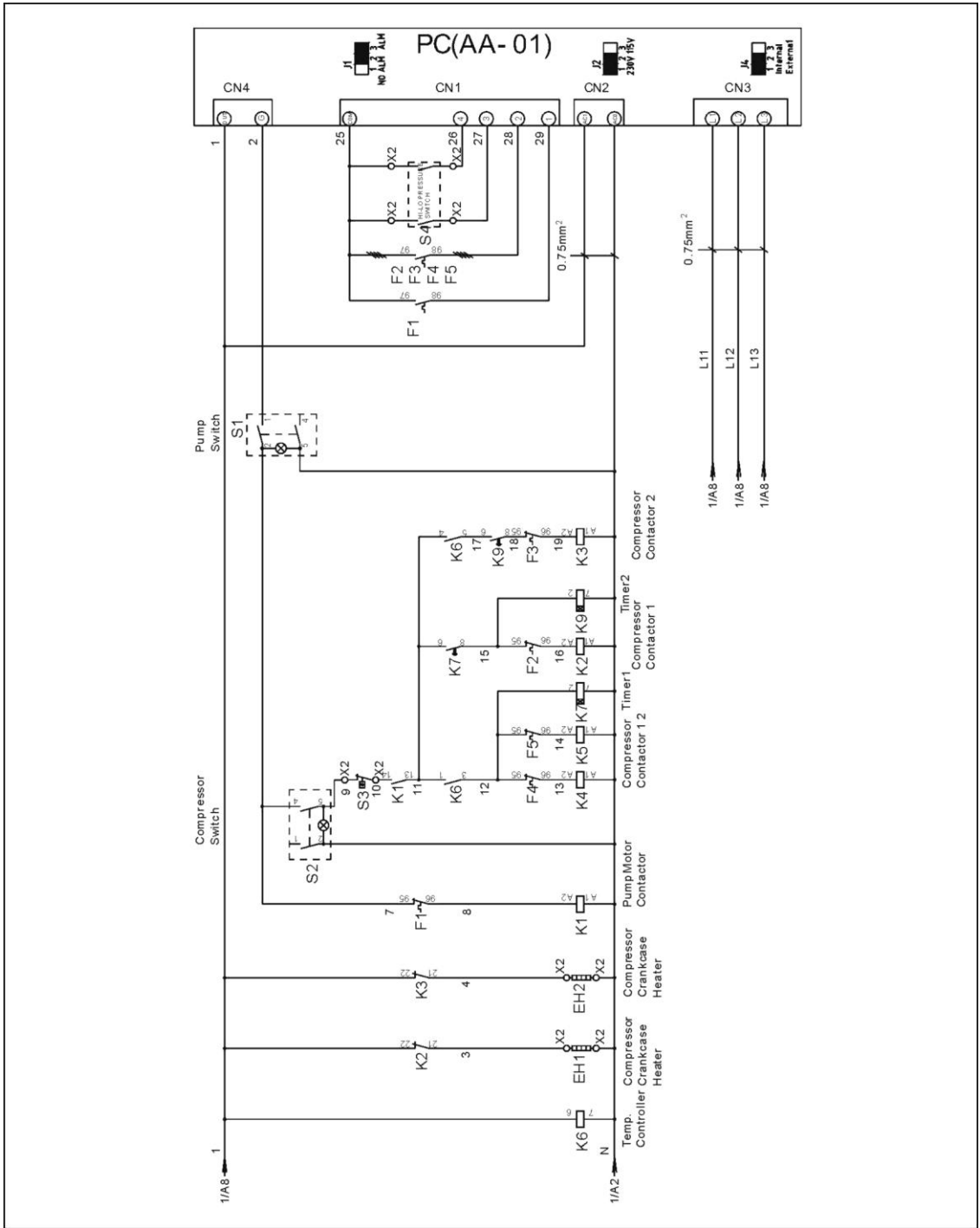

Picture 2-59: Control Circuit (SIC-58A-R2) (400V)

2.3.32 Electrical Components Layout (SIC-58A-R2) (400V)

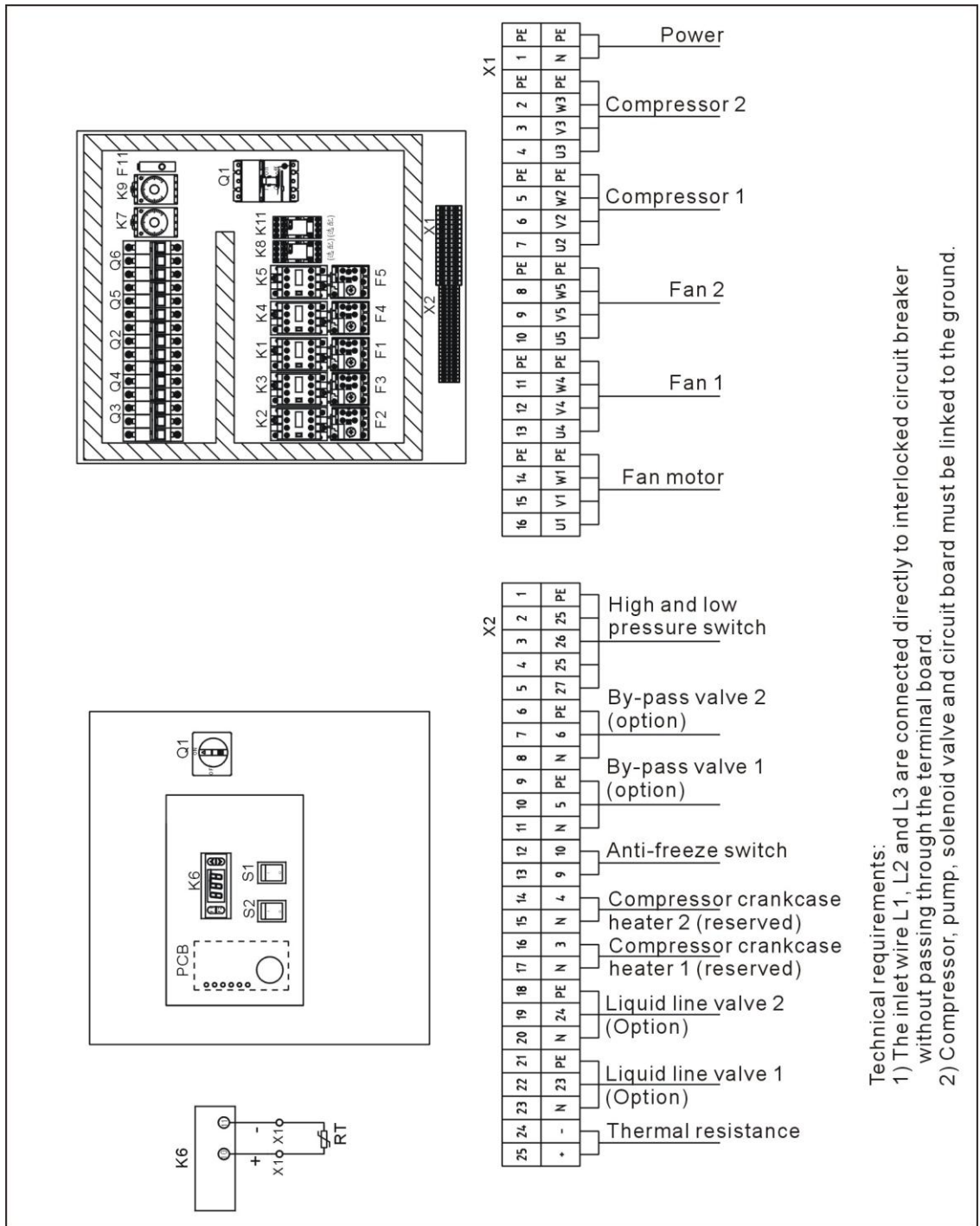

Picture 2-60: Electrical Components Layout (SIC-58A-R2) (400V)

2.3.33 Electrical Components List (SIC-58A-R2) (400V)

Table 2-37: Electrical Components List (SIC-58A-R2) (400V)

No.	Symbol	Name	Specificatons	Parts No.
1	Q1	Circuit breaker *	100A	YE41110000000
2	Q2	Circuit breaker *	20A	YE40602000000
3	Q3 Q4	Circuit breaker *	40A	YE40604000000
4	Q4 Q5	Circuit breaker *	10A	YE40600300000
5	K1	Contacto ^r *	220VAC 50/60Hz	-
6	K2 K3	Contacto ^r *	220VAC 50/60Hz	YE00602722000
7	-	Auxiliary block	2NO+2NC	YE00691100000
8	K4 K5	Contacto ^r *	220VAC 50/60Hz	YE00601521000
9	K6	Temperature controller *	115~230VAC	YE85120200000
10	K7 K9	Timer	3S-60M AC220V	YE86300300000
11	K8 K11	Middle realy	AC220V	YE03270700000
12	F1	Overload relay *	-	-
13	F2 F3	Overload relay *	20~25A	YE01260200000
14	F4 F5	Overload relay *	2.2~3.2A	YE01160220000
15	F11	Fuse**	2A	YE41001000000
16	S1 S2	Control switch *	250V~10(5)A 4P WH	YE10210400000
17	S3	Anti-frozen switch *	-	-
18	S4	HI-LO pressure switch	-	-
19	PCB	Control board *	230V 50/60Hz	YE80000100000
20	X1	Terminal board	-	YE61250040000
21	-	Terminal board	-	YE61253500000
22	-	Terminal board	-	YE61060000000
23	-	Terminal board	-	YE61063500000
24	-	Terminal board	-	YE61160000000
25	-	Terminal board	-	YE61163500000
26	X2	Terminal board	-	YE61250040000
27	-	Terminal board	-	YE61253500000
28	-	Terminal board	-	YE61250040000
29	-	Terminal board	-	YE61253500000
30	-	Terminal board	-	YE61250040000
31	-	Terminal board	-	YE61253500000
32	M1	Pump motor	400V 50/60Hz	-
33	M2 M3	Compressor	400V 50/60Hz 8.82kW	-

34	M4 M5	Fan motor	400V 50/60Hz 1.03kW	-
No.	Symbol	Name	Specificatons	Parts No.
35	EH1	Compressor crankcase heater	230V 50/60Hz	-
36	Y1 Y2	Solenoid valve**	230V 50/60Hz	-
37	Y3 Y4	Solenoid valve**	230V 50/60Hz	-

* means possible broken parts. ** means easy broken parts. Spare backup is suggested. Please confirm the version number of the manual before you order to ensure the stock number and the parts are consistent.

2.3.35 Control Circuit (SIC-75A-R2) (400V)

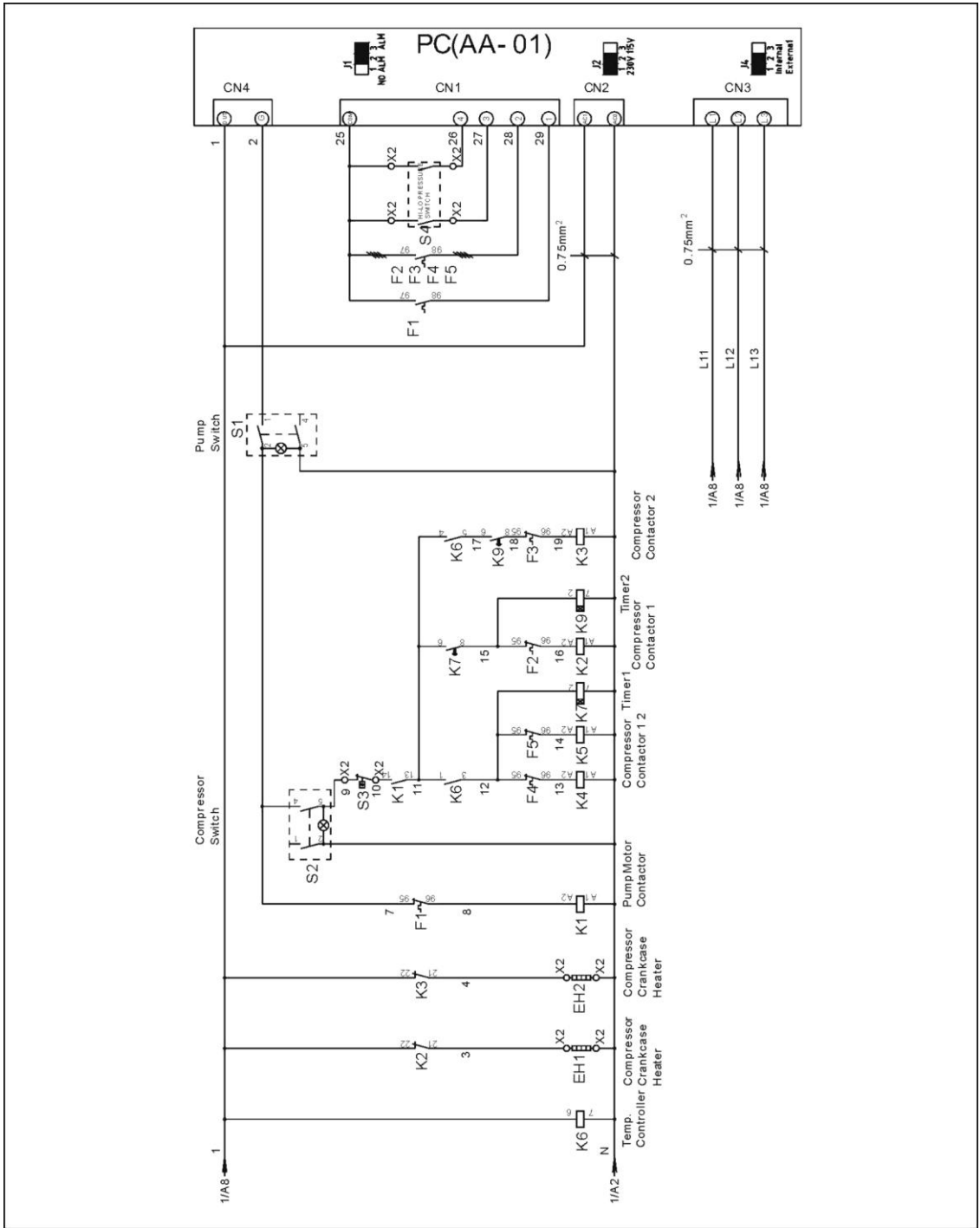

Picture 2-62: Control Circuit (SIC-75A-R2) (400V)

2.3.36 Electrical Components Layout (SIC-75A-R2) (400V)

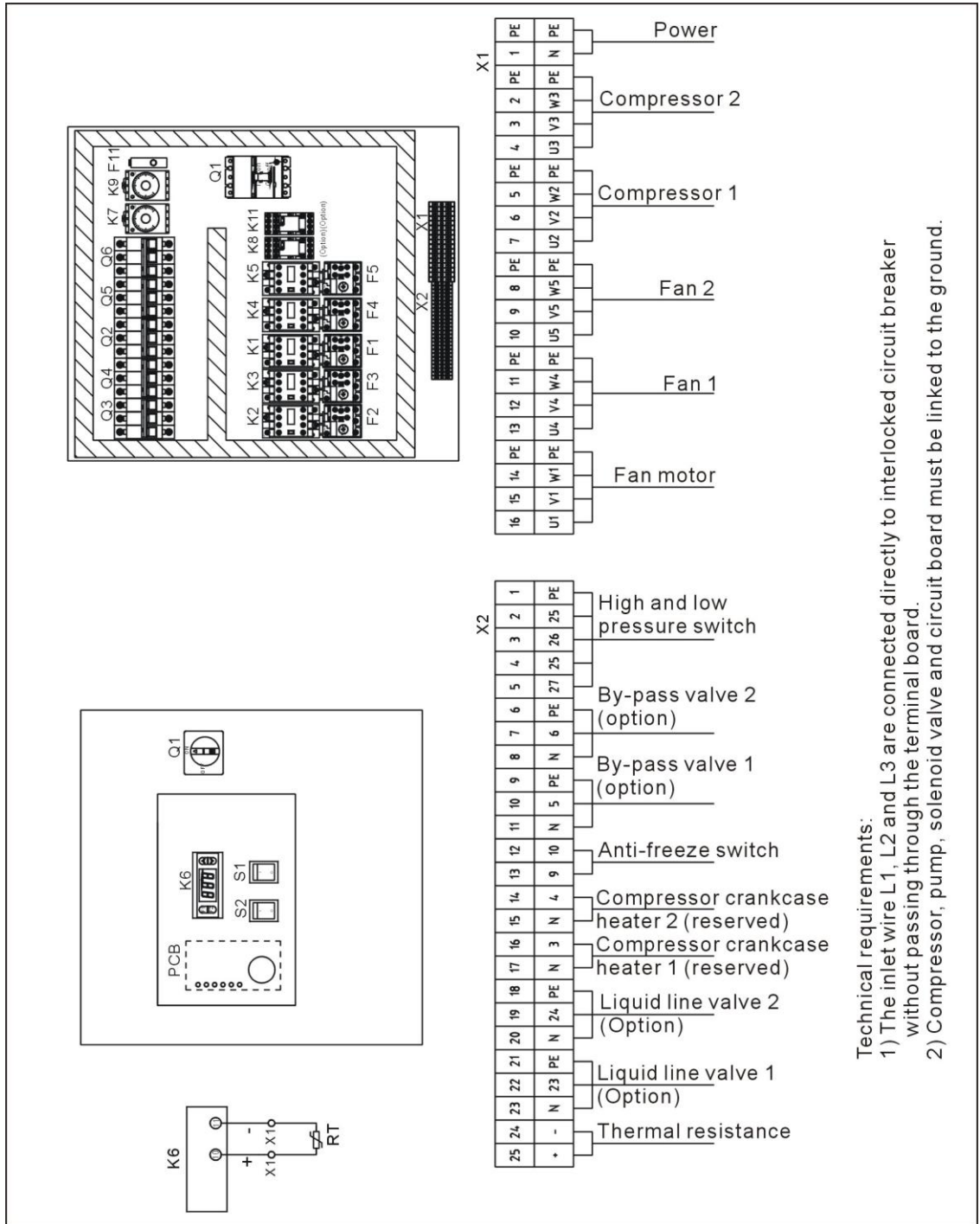

Picture 2-63: Electrical Components Layout (SIC-75A-R2) (400V)

2.3.37 Electrical Components List (SIC-75A-R2) (400V)

Table 2-38: Electrical Components List (SIC-75A-R2) (400V)

No.	Symbol	Name	Specificatons	Parts No.
1	Q1	Circuit breaker *	100A	YE41110000000
2	Q2	Circuit breaker *	20A	YE40602000000
3	Q3 Q4	Circuit breaker *	60A	YE40606000000
4	Q4 Q5	Circuit breaker *	10A	YE40600300000
5	K1	Contactor *	220VAC 50/60Hz	-
6	K2 K3	Contactor *	220VAC 50/60Hz	YE00602822000
7	-	Auxiliary block	2NO+2NC	YE00691100000
8	K4 K5	Contactor *	220VAC 50/60Hz	YE00601521000
9	K6	Temperature controller *	115~230VAC	YE85120200000
10	K7 K9	Timer	3S-60M AC220V	YE86300300000
11	K8 K11	Middle realy	AC220V	YE03270700000
12	F1	Overload relay *	-	-
13	F2 F3	Overload relay *	27~32A	YE01612600600
14	F4 F5	Overload relay *	3.5~5A	YE01160350000
15	F11	Fuse**	2A	YE41001000000
16	S1 S2	Control switch *	250V~10(5)A 4P WH	YE10210400000
17	S3	Anti-frozen switch *	-	-
18	S4	HI-LO pressure switch	-	-
19	PCB	Control board *	230V 50/60Hz	YE80000100000
20	X1	Terminal board	-	YE61250040000
21	-	Terminal board	-	YE61253500000
22	-	Terminal board	-	YE61060000000
23	-	Terminal board	-	YE61063500000
24	-	Terminal board	-	YE61350040000
25	-	Terminal board	-	YE61353500000
26	X2	Terminal board	-	YE61250040000
27	-	Terminal board	-	YE61253500000
28	-	Terminal board	-	YE61250040000
29	-	Terminal board	-	YE61253500000
30	-	Terminal board	-	YE61250040000
31	-	Terminal board	-	YE61253500000
32	M1	Pump motor	400V 50/60Hz	-
33	M2 M3	Compressor	400V 50/60Hz 11.03kW	-

34	M4 M5	Fan motor	400V 50/60Hz 1.92kW	-
No.	Symbol	Name	Specificatons	Parts No.
35	EH1	Compressor crankcase heater	230V 50/60Hz	-
36	Y1 Y2	Solenoid valve**	230V 50/60Hz	-
37	Y3 Y4	Solenoid valve**	230V 50/60Hz	-

* means possible broken parts. ** means easy broken parts. Spare backup is suggested. Please confirm the version number of the manual before you order to ensure the stock number and the parts are consistent.

2.3.38 Main Electrical Circuit (SIC-100A-R2) (400V)

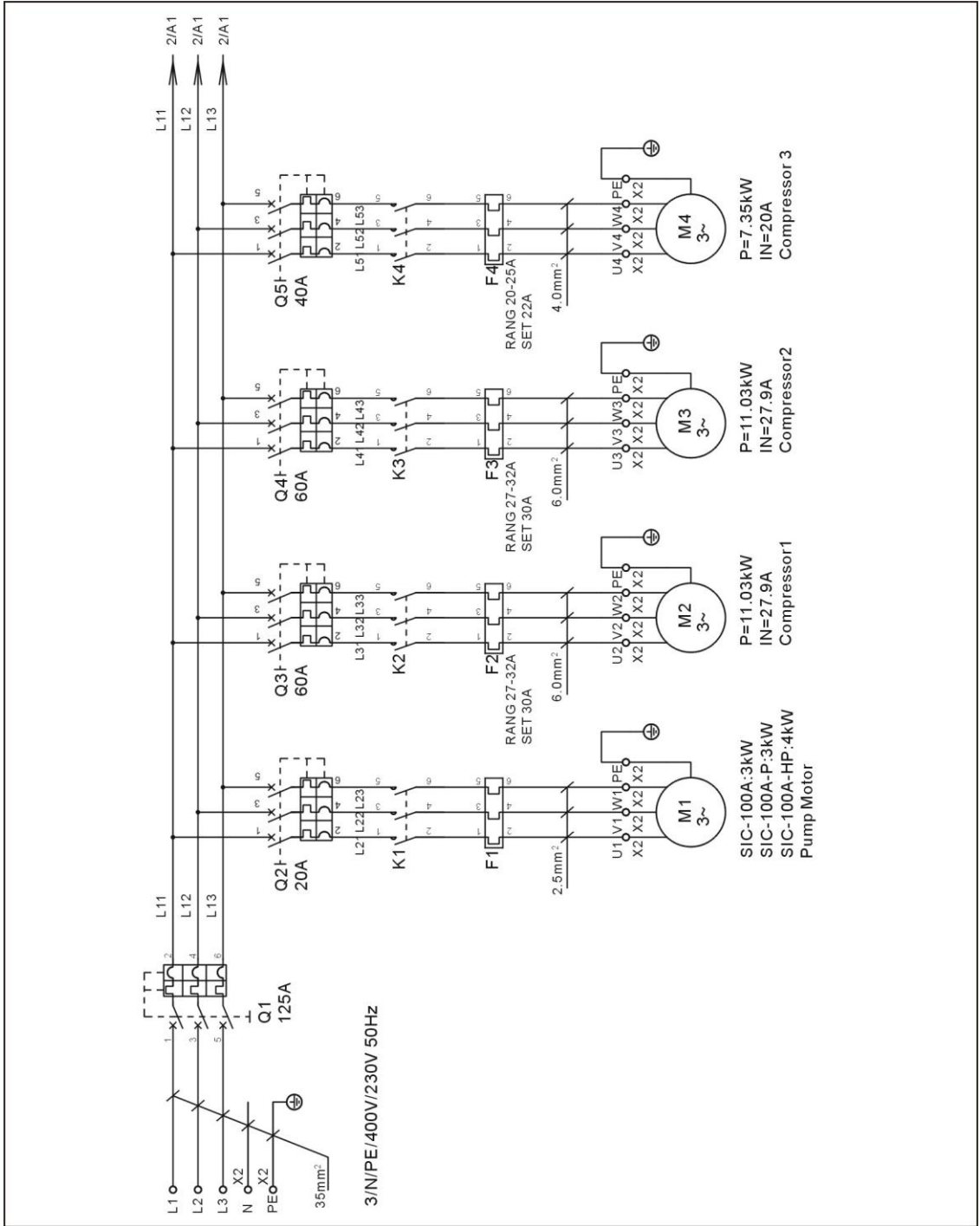

Picture 2-64: Main Electrical Circuit 1(SIC-100A-R2) (400V)

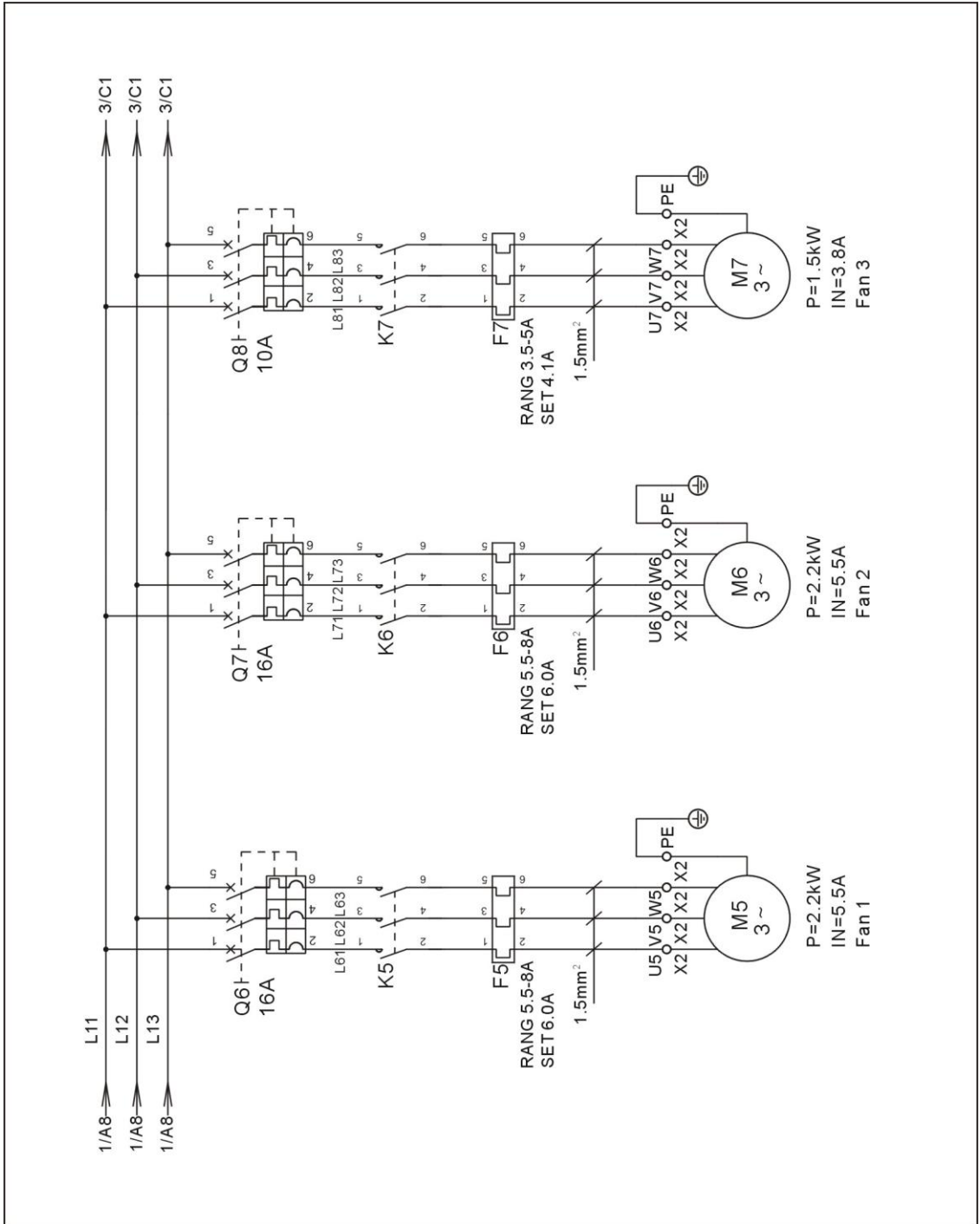

Picture 2-65: Main Electrical Circuit 2(SIC-100A-R2) (400V)

2.3.39 Control Circuit (SIC-100A-R2) (400V)

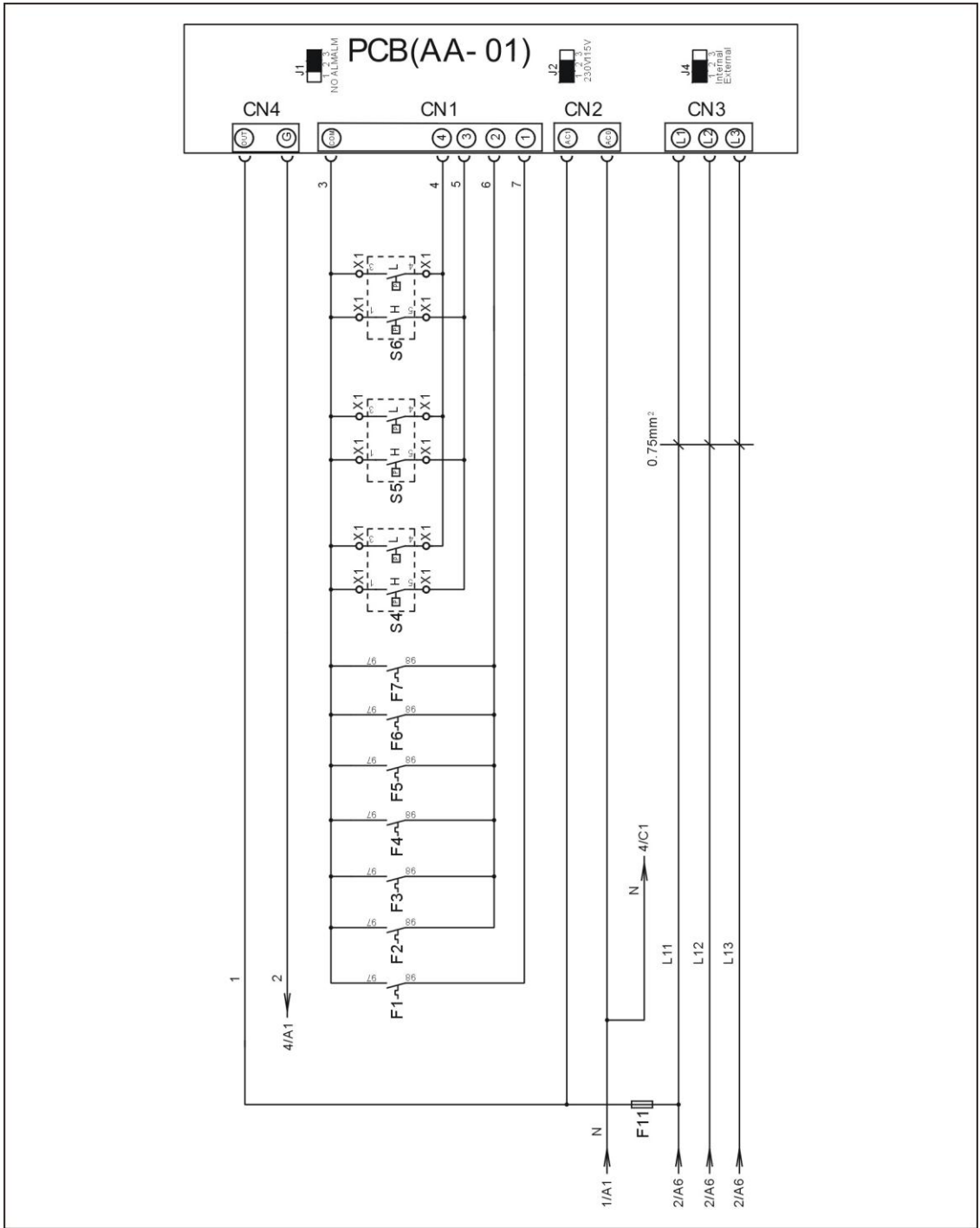

Picture 2-66: Control Circuit 1(SIC-100A-R2) (400V)

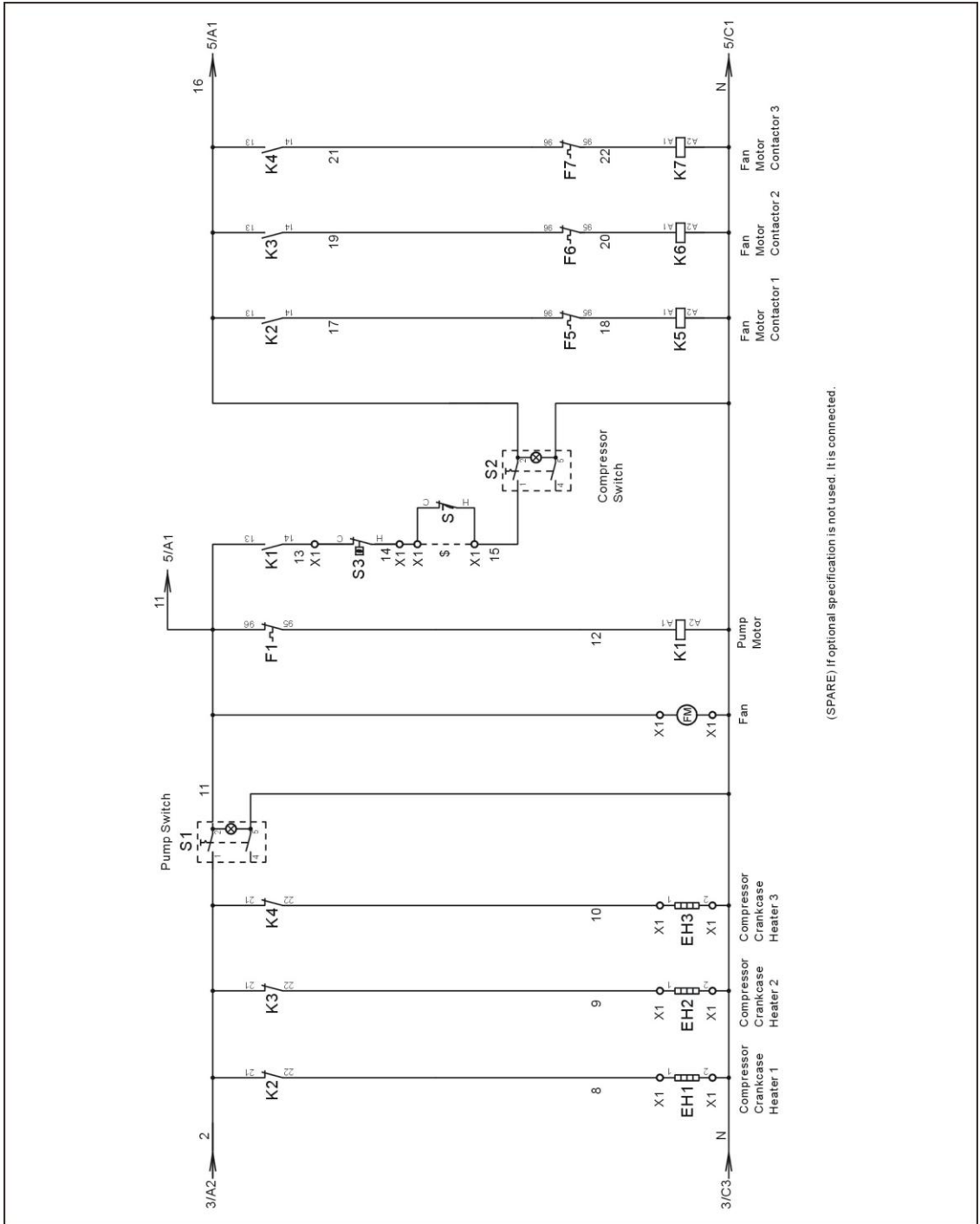

(SPARE) If optional specification is not used, it is connected.

Picture 2-67: Control Circuit 2(SIC-100A-R2) (400V)

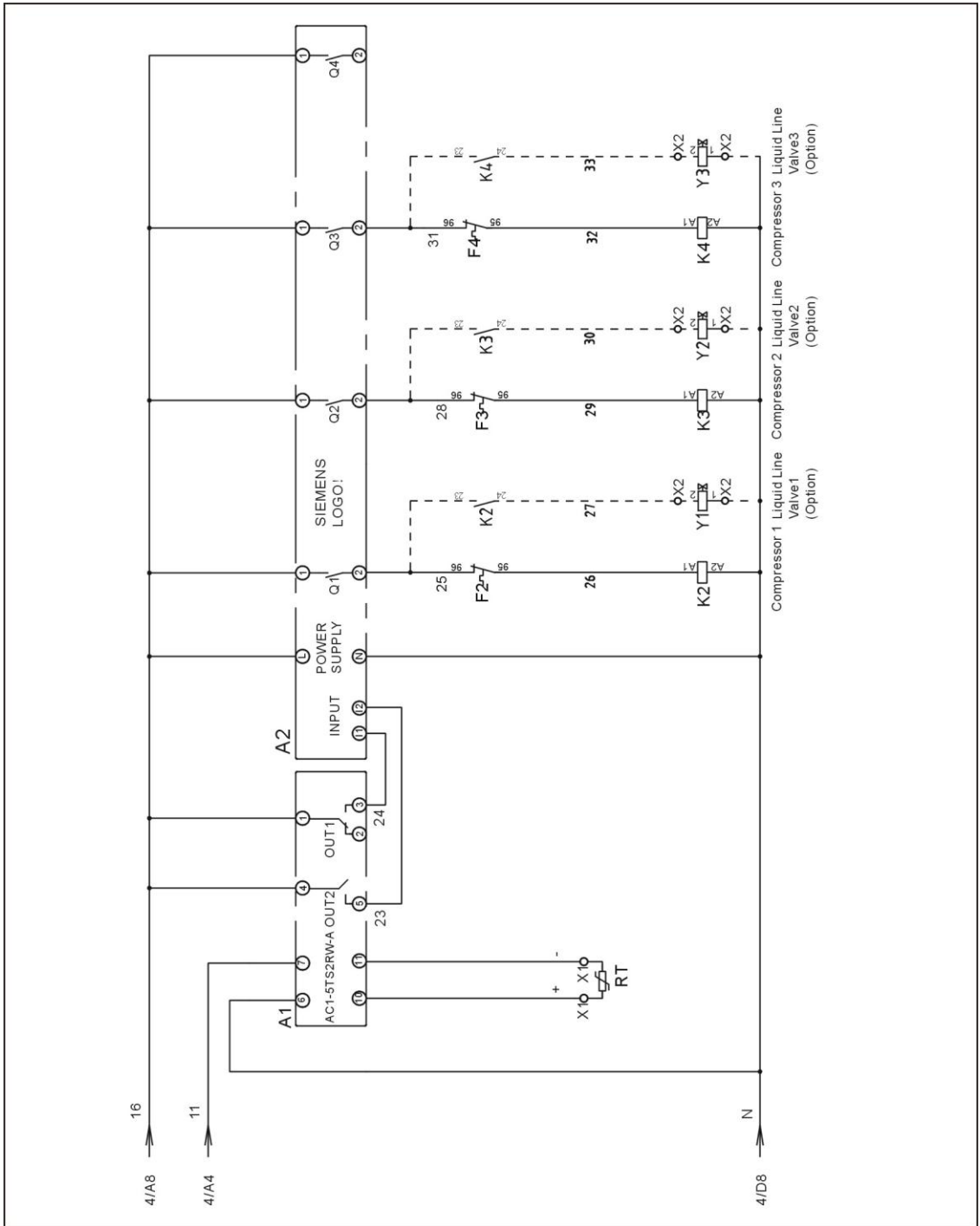

Picture 2-68: Control Circuit 3(SIC-100A-R2) (400V)

2.3.40 Electrical Components Layout (SIC-100A-R2) (400V)

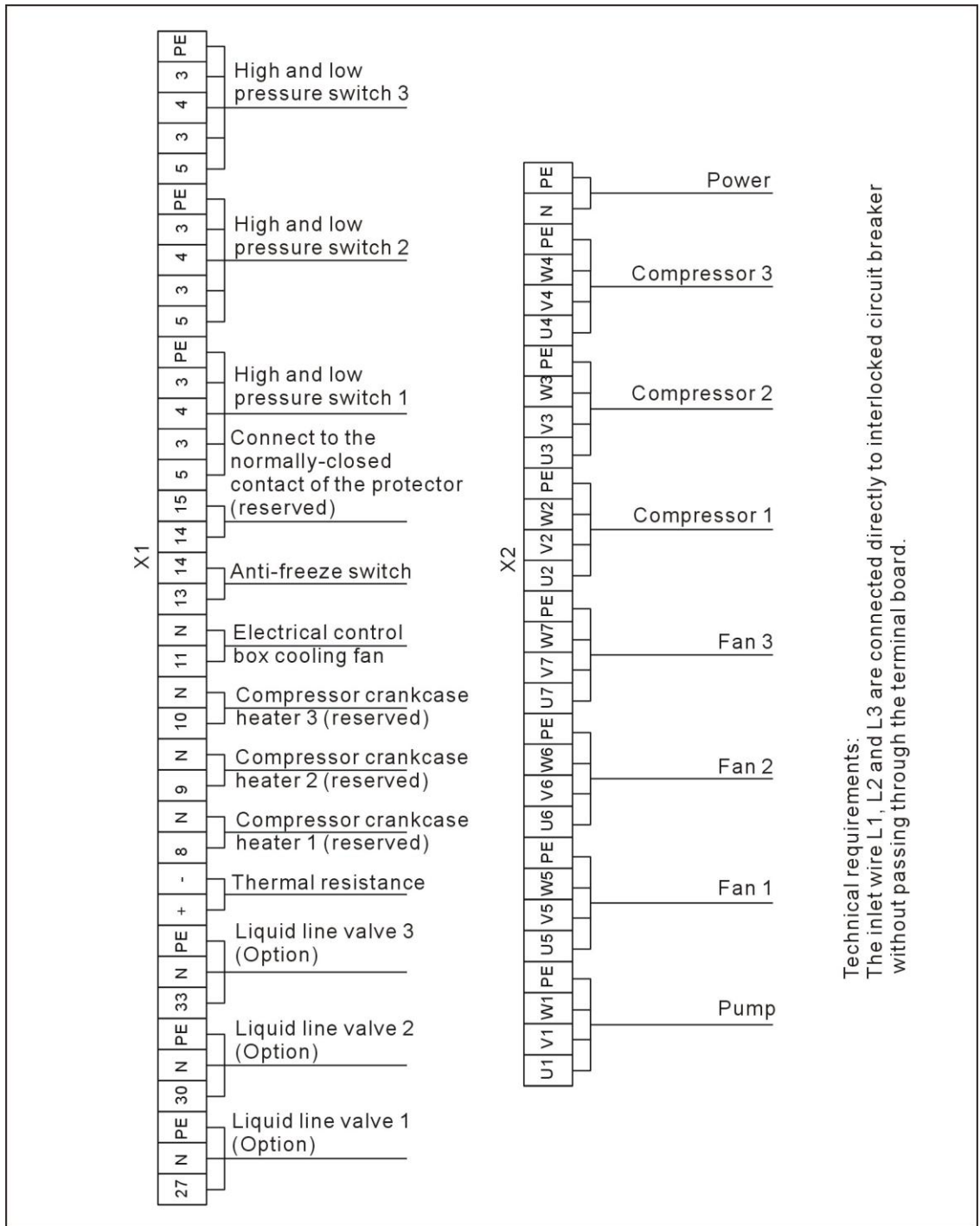

Picture 2-69: Electrical Components Layout 1(SIC-100A-R2) (400V)

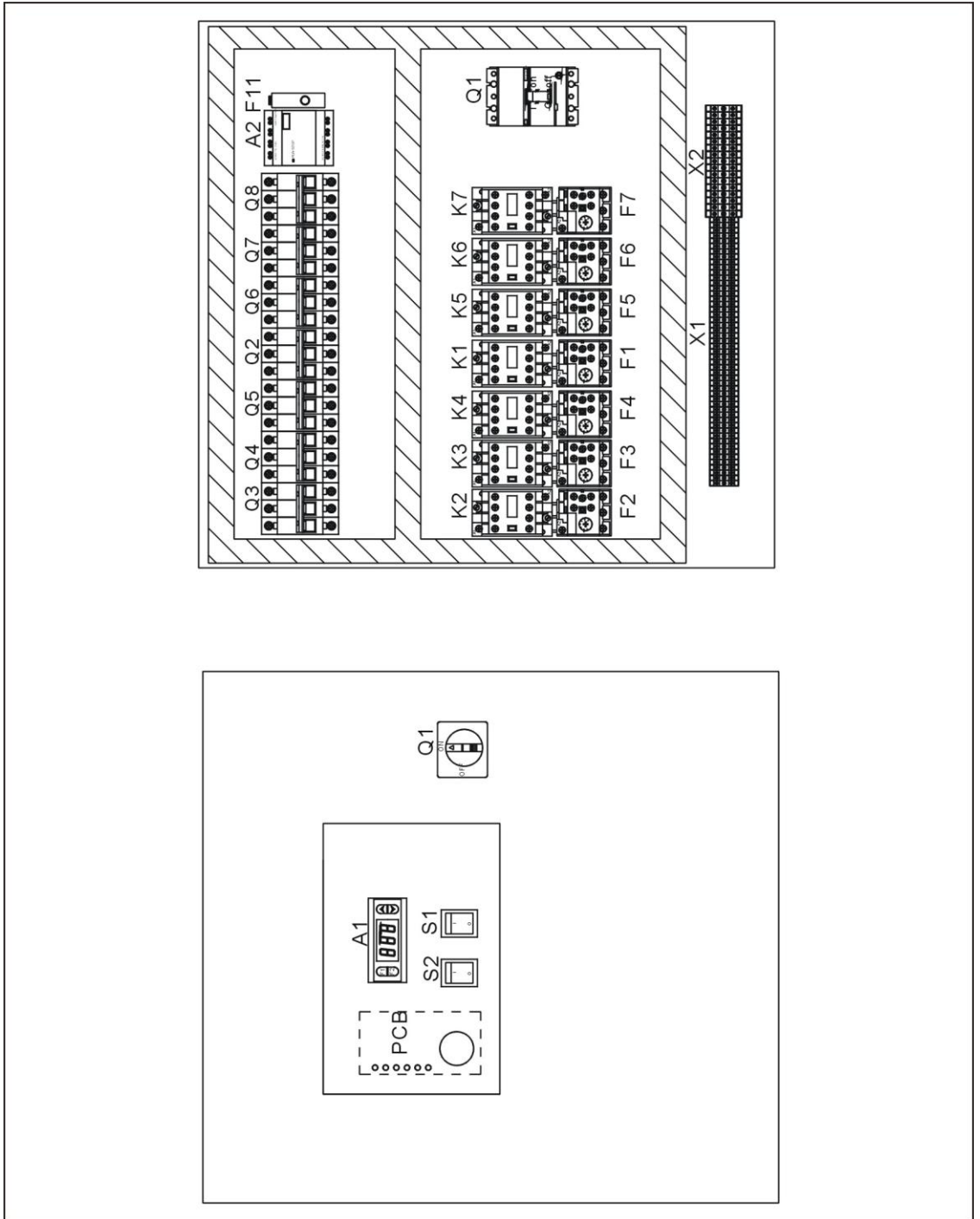

Picture 2-70: Electrical Components Layout 2(SIC-100A-R2) (400V)

2.3.41 Electrical Components List (SIC-100A-R2) (400V)

Table 2-39: Electrical Components List (SIC-100A-R2) (400V)

No.	Symbol	Name	Specificatons	Parts No.
1	Q1	Circuit breaker *	125A	YE41161200000
2	Q2	Circuit breaker *	20A	YE40602000000
3	Q3 Q4	Circuit breaker *	60A	YE40606000000
4	Q5	Circuit breaker *	40A	YE40600400000
5	Q6 Q7	Circuit breaker *	16A	YE40601500000
6	Q8	Circuit breaker *	10A	YE40600300000
7	K1	Contactor *	220VAC 50/60Hz	-
8	K2 K3	Contactor *	220VAC 50/60Hz	YE00602822000
9	K4	Contactor *	220VAC 50/60Hz	YE00602722000
10	-	Auxiliary block	1NO	YE00691110000
11	K5~K7	Contactor *	220VAC 50/60Hz	YE00601521000
12	A1	Temperature controller *	115~230VAC	YE85120200000
13	A2	LOGO! Controller	AC115~230V	YE81023000000
14	RT	Temperature sensor	-	-
15	F1	Overload relay *	-	-
16	F2 F3	Overload relay *	27~32A	YE01612600600
17	F4	Overload relay *	20~25A	YE01260200000
18	F5 F6	Overload relay *	5.5~8A	YE01160550000
19	F7	Overload relay *	3.5~5A	YE01160350000
20	F11	Fuse**	2A	YE41001000000
21	S1 S2	Control switch *	250V~10(5)A 4P WH	YE10210400000
22	S3	Anti-frozen switch *	-	-
23	S4~S6	HI-LO pressure switch	H:5~30bar L:-0.7~6bar	-
24	PCB	Control board *	230V 50/60Hz	YE80000100000
25	X1	Terminal board	-	YE61250040000
26	-	Terminal board	-	YE61253500000
27	-	Terminal board	-	YE61250040000
28	-	Terminal board	-	YE61253500000
29	X2	Terminal board	-	YE61040000000
30	-	Terminal board	-	YE61043500000
31	-	Terminal board	-	YE61060000000
32	-	Terminal board	-	YE61063500000
33	-	Terminal board	-	YE61350040000

34	-	Terminal board	-	YE61253500000
No.	Symbol	Name	Specificatons	Parts No.
35	-	Terminal board	-	YE61250040000
36	-	Terminal board	-	YE61253500000
37	M1	Pump motor	400V 50/60Hz	-
38	M2 M3	Compressor	400V 50/60Hz 11.03kW	-
39	M4	Compressor	400V 50/60Hz 7.35kW	-
40	M5	Fan motor	400V 50/60Hz 2.2kW	-
41	M6 M7	Fan motor	400V 50/60Hz 1.5kW	-
42	EH1~EH3	Compressor crankcase heater	230V 50/60Hz 45W	-
43	Y1~Y3	Solenoid valve**	230V 50/60Hz	-

* means possible broken parts. ** means easy broken parts. Spare backup is suggested. Please confirm the version number of the manual before you order to ensure the stock number and the parts are consistent.

2.3.42 Main Electrical Circuit (SIC-114A-R2) (400V)

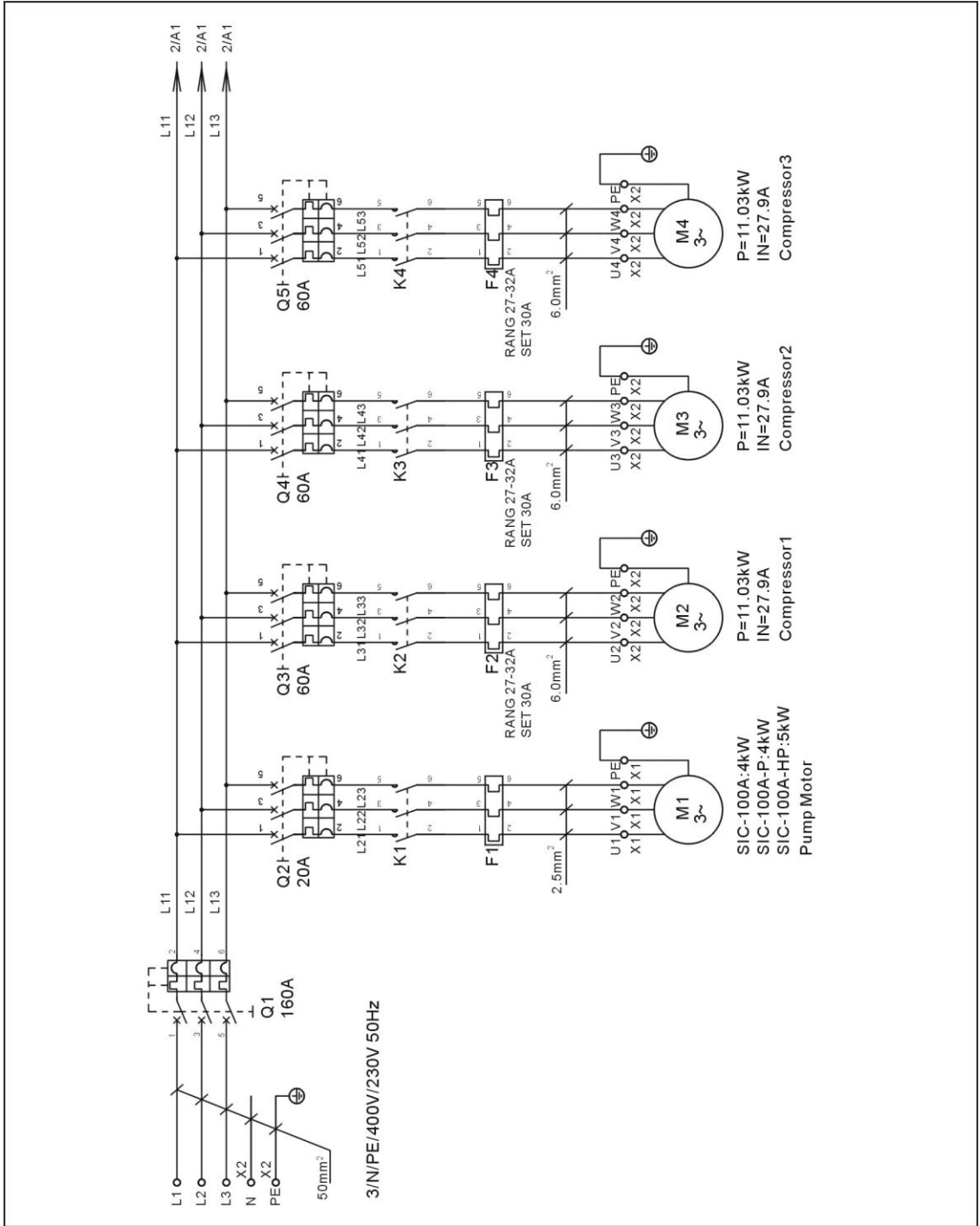

Picture 2-71: Main Electrical Circuit 1(SIC-114A-R2) (400V)

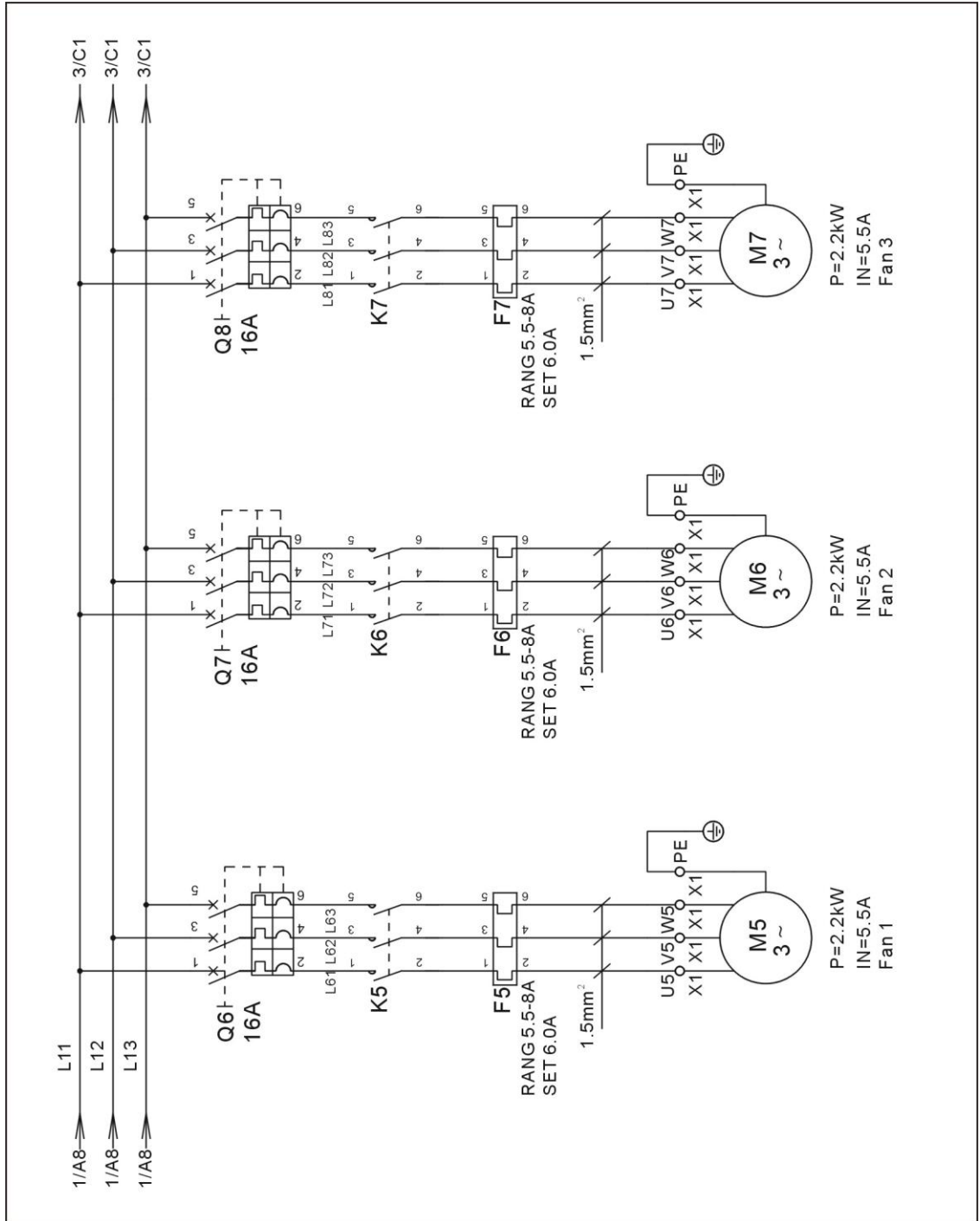

Picture 2-72: Main Electrical Circuit 2(SIC-114A-R2) (400V)

2.3.43 Control Circuit (SIC-114A-R2) (400V)

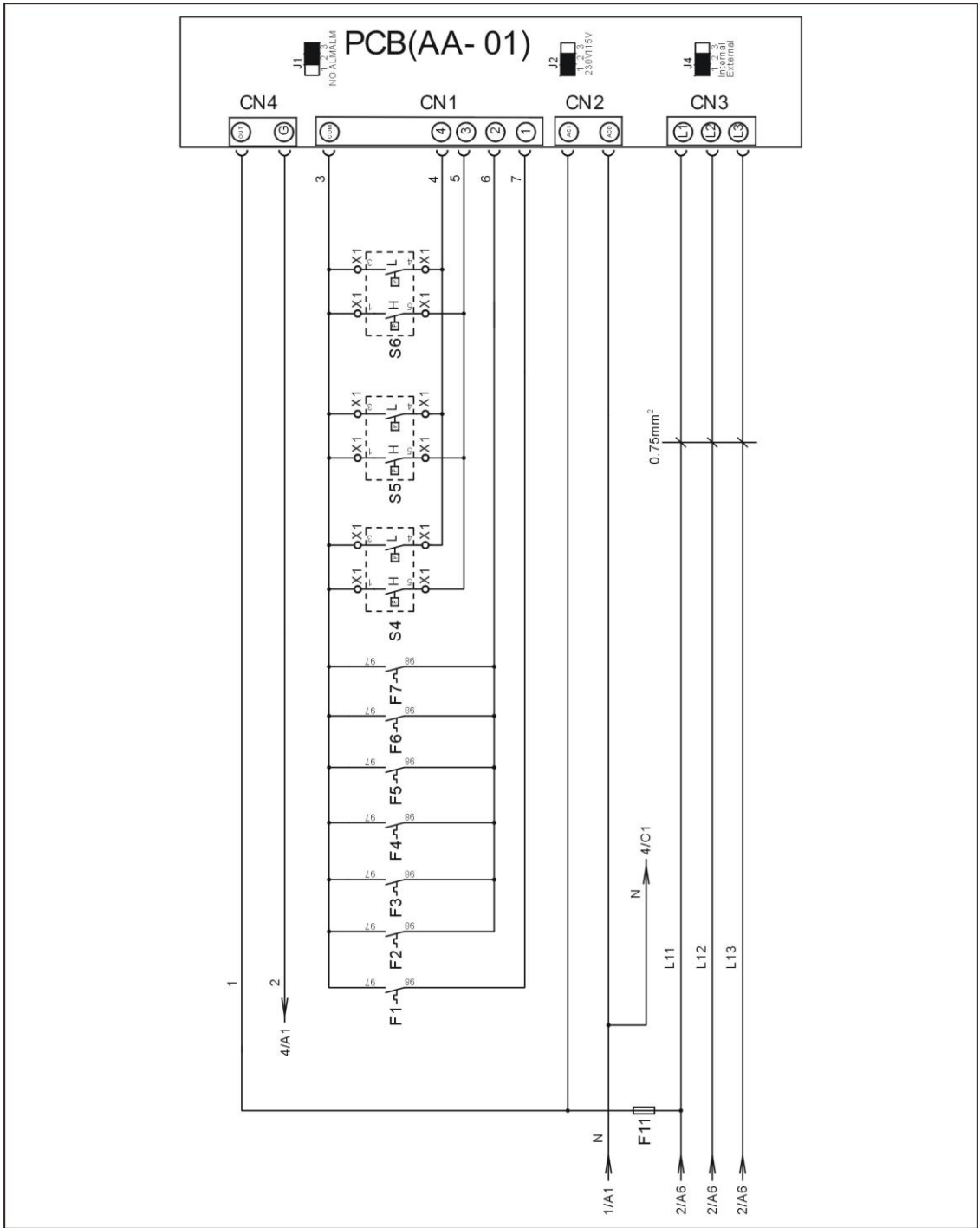

Picture 2-73: Control Circuit 1(SIC-114A-R2) (400V)

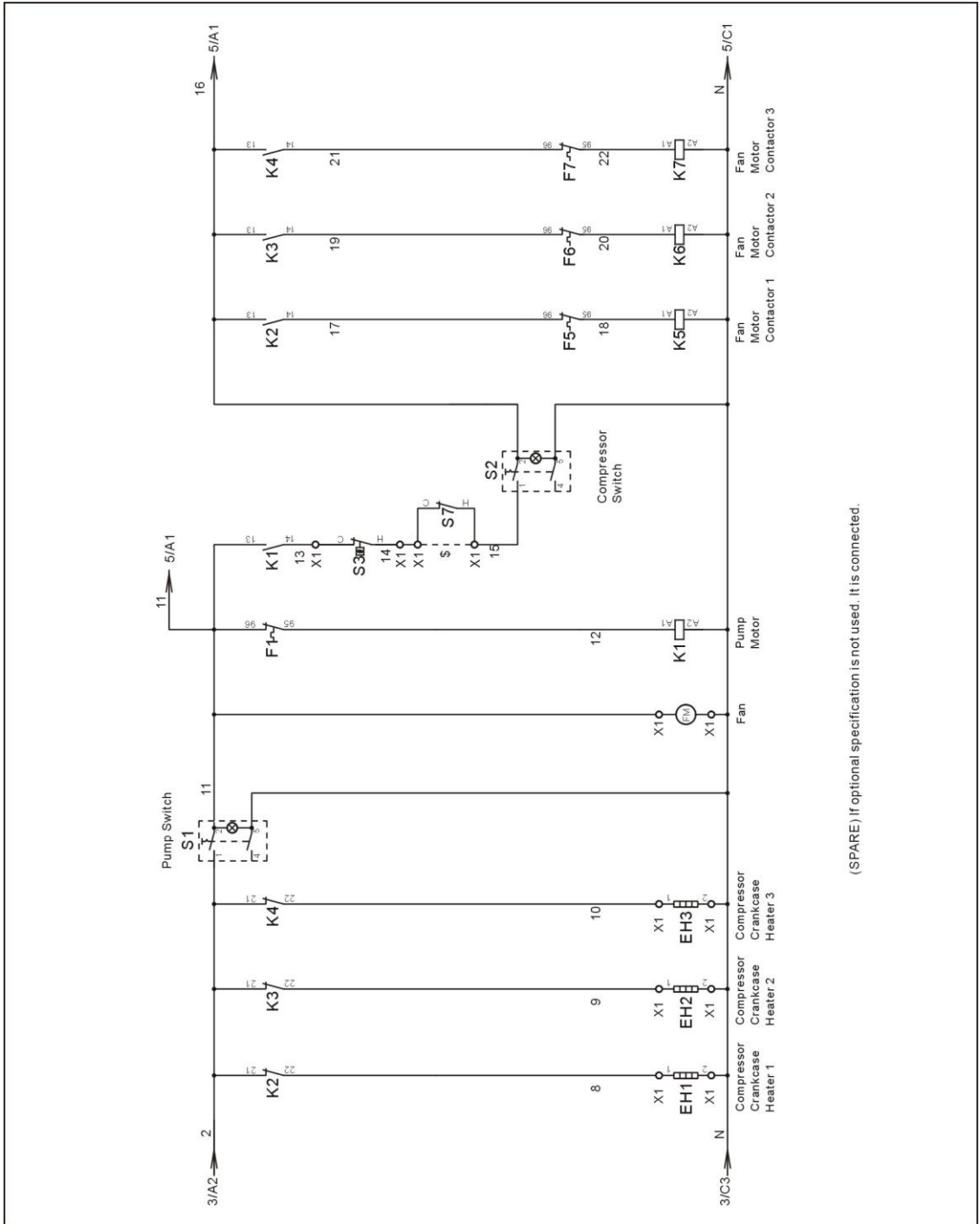

(SPARE) If optional specification is not used, it is connected.

Picture 2-74: Control Circuit 2(SIC-114A-R2) (400V)

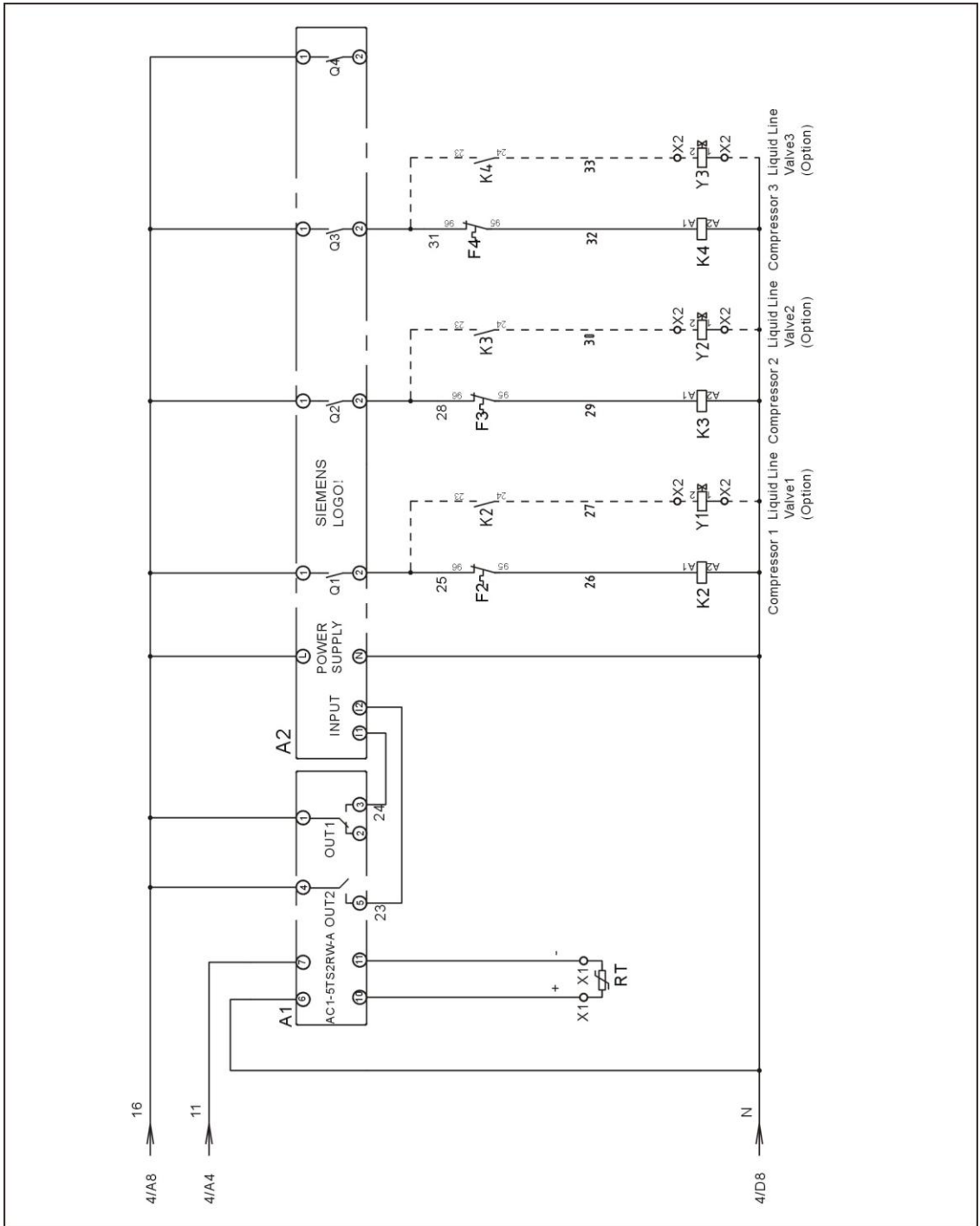

Picture 2-75: Control Circuit 3(SIC-114A-R2) (400V)

2.3.44 Electrical Components Layout (SIC-114A-R2) (400V)

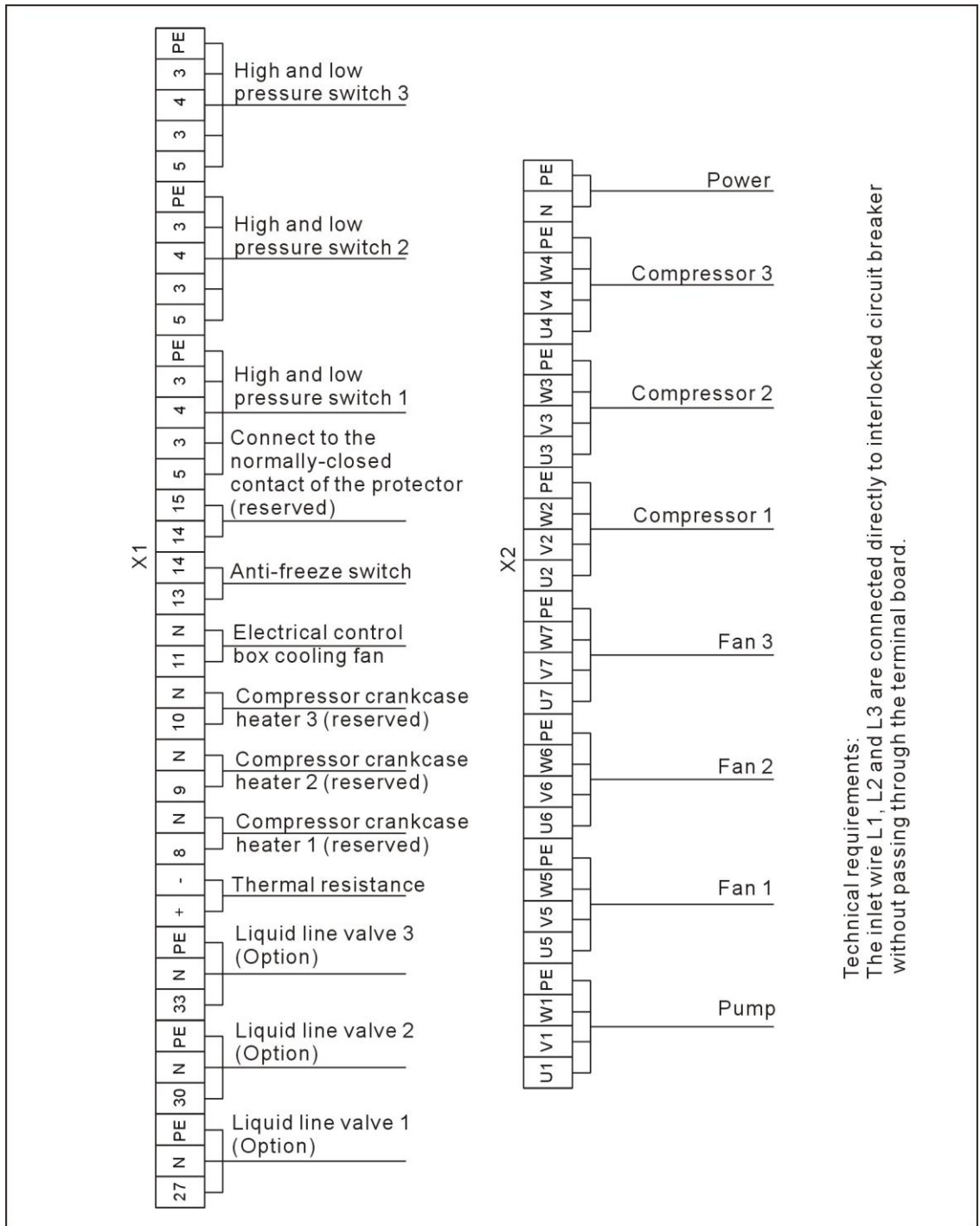

Picture 2-76: Electrical Components Layout 1(SIC-114A-R2) (400V)

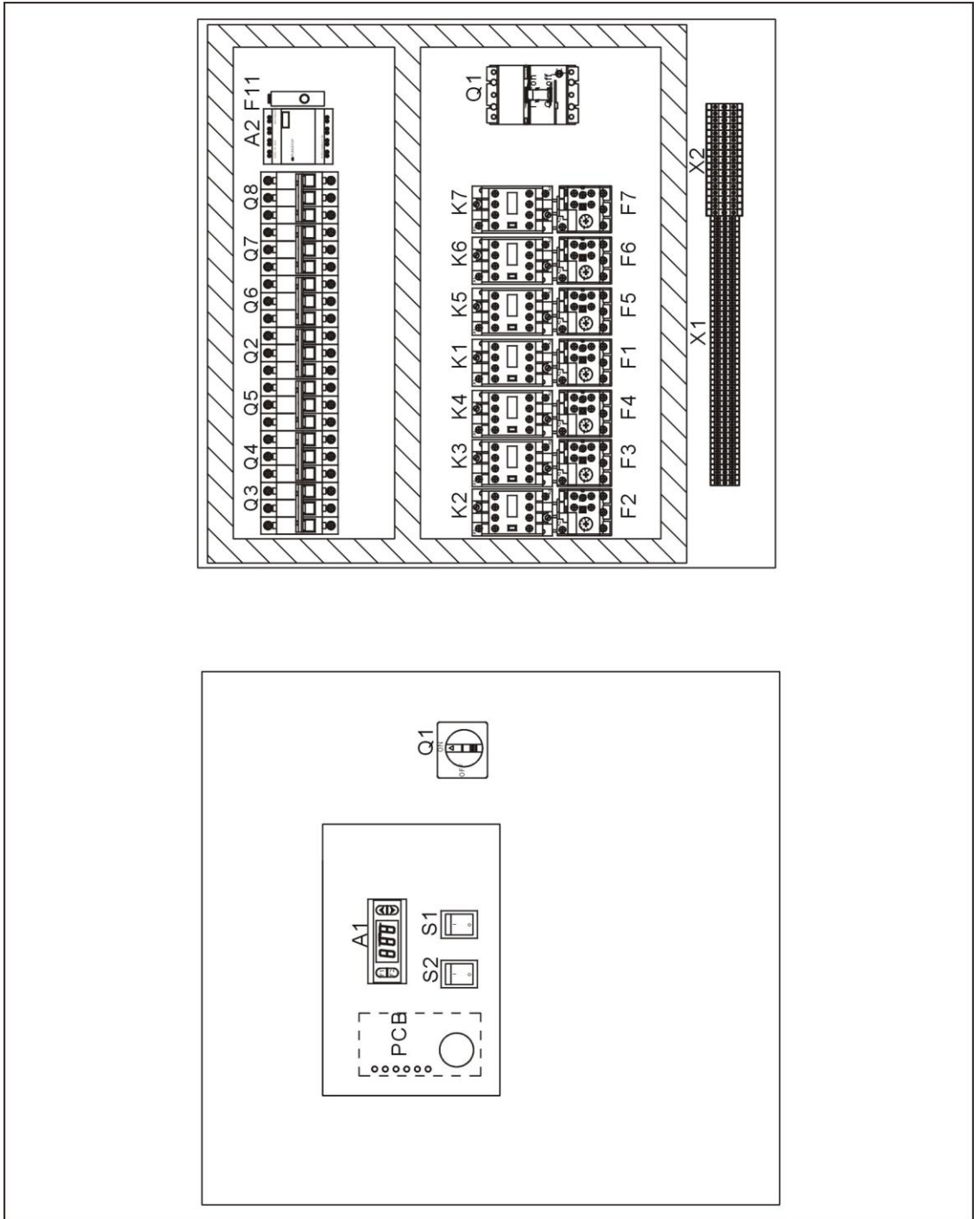

Picture 2-77: Electrical Components Layout 2(SIC-114A-R2) (400V)

2.3.45 Electrical Components List (SIC-114A-R2) (400V)

Table 2-40: Electrical Components List (SIC-114A-R2) (400V)

No.	Symbol	Name	Specificatons	Parts No.
1	Q1	Circuit breaker *	160A	YE41161600000
2	Q2	Circuit breaker *	20A	YE40602000000
3	Q3~Q5	Circuit breaker *	60A	YE40606000000
4	Q6~Q8	Circuit breaker *	16A	YE40601500000
5	K1	Contactora *	220VAC 50/60Hz	-
6	K2~K4	Contactora *	220VAC 50/60Hz	YE00602822000
7	-	Auxiliary block	1NO	YE00691110000
8	K5~K7	Contactora *	220VAC 50/60Hz	YE00601521000
9	A1	Temperature controller *	115~230VAC	YE85120200000
10	A2	LOGO! Controller	AC115~230V	YE81023000000
11	RT	Temperature sensor	-	-
12	F1	Overload relay *	-	-
13	F2~F4	Overload relay *	27~32A	YE01612600600
14	F5~F7	Overload relay *	5.5~8A	YE01160550000
15	F11	Fuse**	2A	YE41001000000
16	S1 S2	Control switch *	250V~10(5)A 4P WH	YE10210400000
17	S3	Anti-frozen switch *	-	-
18	S4~S6	HI-LO pressure switch	H:5~30bar L:-0.7~6bar	-
19	PCB	Control board *	230V 50/60Hz	YE80000100000
20	X1	Terminal board	-	YE61250040000
21	-	Terminal board	-	YE61253500000
22	-	Terminal board	-	YE61250040000
23	-	Terminal board	-	YE61253500000
24	X2	Terminal board	-	YE61040000000
25	-	Terminal board	-	YE61043500000
26	-	Terminal board	-	YE61060000000
27	-	Terminal board	-	YE61063500000
28	-	Terminal board	-	YE61350040000
29	-	Terminal board	-	YE61253500000
30	-	Terminal board	-	YE61250040000
31	-	Terminal board	-	YE61253500000
32	M1	Pump motor	400V 50/60Hz	-
33	M2~M4	Compressor	400V 50/60Hz 11.03kW	-

34	M5~M7	Fan motor	400V 50/60Hz 2.2kW	-
No.	Symbol	Name	Specificatons	Parts No.
35	EH1~EH3	Compressor crankcase heater	230V 50/60Hz 45W	-
36	Y1~Y3	Solenoid valve**	230V 50/60Hz	-

* means possible broken parts. ** means easy broken parts. Spare backup is suggested. Please confirm the version number of the manual before you order to ensure the stock number and the parts are consistent.

2.3.46 Selection Table of Pump Contactor and Thermal Overload Relay (230V)

Table 2-41: Selection Table of Pump Contactor and Thermal Overload Relay (Low Pressure) (230V)

Model	Power (kw)	Stock No.	
		Contactor	Thermal Overload Relay
SIC-7.5A-R2	0.75	YE00601521000	YE01160280000
SIC-12A-R2	0.75	YE00601521000	YE01160280000
SIC-18A-R2	1.1	YE00601521000	YE01160450000
SIC-24A-R2	1.1	YE00601521000	YE01160450000
SIC-28A-R2	1.1	YE00601521000	YE01160450000
SIC-38A-R2	1.1	YE00601521000	YE01160450000
SIC-48A-R2	2.2	YE00601721000	YE01169125000
SIC-58A-R2	2.2	YE00601721000	YE01169125000
SIC-75A-R2	2.2	YE00601721000	YE01169125000
SIC-100A-R2	3.0	YE00602522000	YE01260110000
SIC-114A-R2	4.0	YE00602622000	YE01260140000

Table 2-42: Selection Table of Pump Contactor and Thermal Overload Relay (Medium Pressure) (230V)

Model	Power (kw)	Stock No.	
		Contactor	Thermal Overload Relay
SIC-7.5A-R2-P	0.75	YE00601521000	YE01160280000
SIC-12A-R2-P	0.75	YE00601521000	YE01160280000
SIC-18A-R2-P	1.1	YE00601521000	YE01160450000
SIC-24A-R2-P	1.1	YE00601521000	YE01160450000
SIC-28A-R2-P	1.5	YE00601521000	YE01160550000
SIC-38A-R2-P	1.5	YE00601521000	YE01160550000
SIC-48A-R2-P	3.0	YE00602522000	YE01260110000
SIC-58A-R2-P	3.0	YE00602522000	YE01260110000
SIC-75A-R2-P	3.0	YE00602522000	YE01260110000
SIC-100A-R2-P	3.0	YE00602522000	YE01260110000
SIC-114A-R2-P	4.0	YE00602622000	YE01260140000

Table 2-43: Selection Table of Pump Contactor and Thermal Overload Relay (High Pressure) (230V)

Model	Power (kw)	Stock No.	
		Contactor	Thermal Overload Relay
SIC-7.5A-R2-HP	1.1	YE00601521000	YE01160450000
SIC-12A-R2-HP	1.1	YE00601521000	YE01160450000
SIC-18A-R2-HP	1.1	YE00601521000	YE01160450000
SIC-24A-R2-HP	1.1	YE00601521000	YE01160450000
SIC-28A-R2-HP	2.2	YE00601721000	YE01169125000
SIC-38A-R2-HP	2.2	YE00601721000	YE01169125000
SIC-48A-R2-HP	4.0	YE00602622000	YE01160140000
SIC-58A-R2-HP	4.0	YE00602622000	YE01160140000
SIC-75A-R2-HP	4.0	YE00602622000	YE01160140000
SIC-100A-R2-HP	4.0	YE00602622000	YE01160140000
SIC-114A-R2-HP	5.5	YE00602722000	YE01260200000

2.3.47 Main Electrical Circuit (SIC-7.5A-R2) (230V)

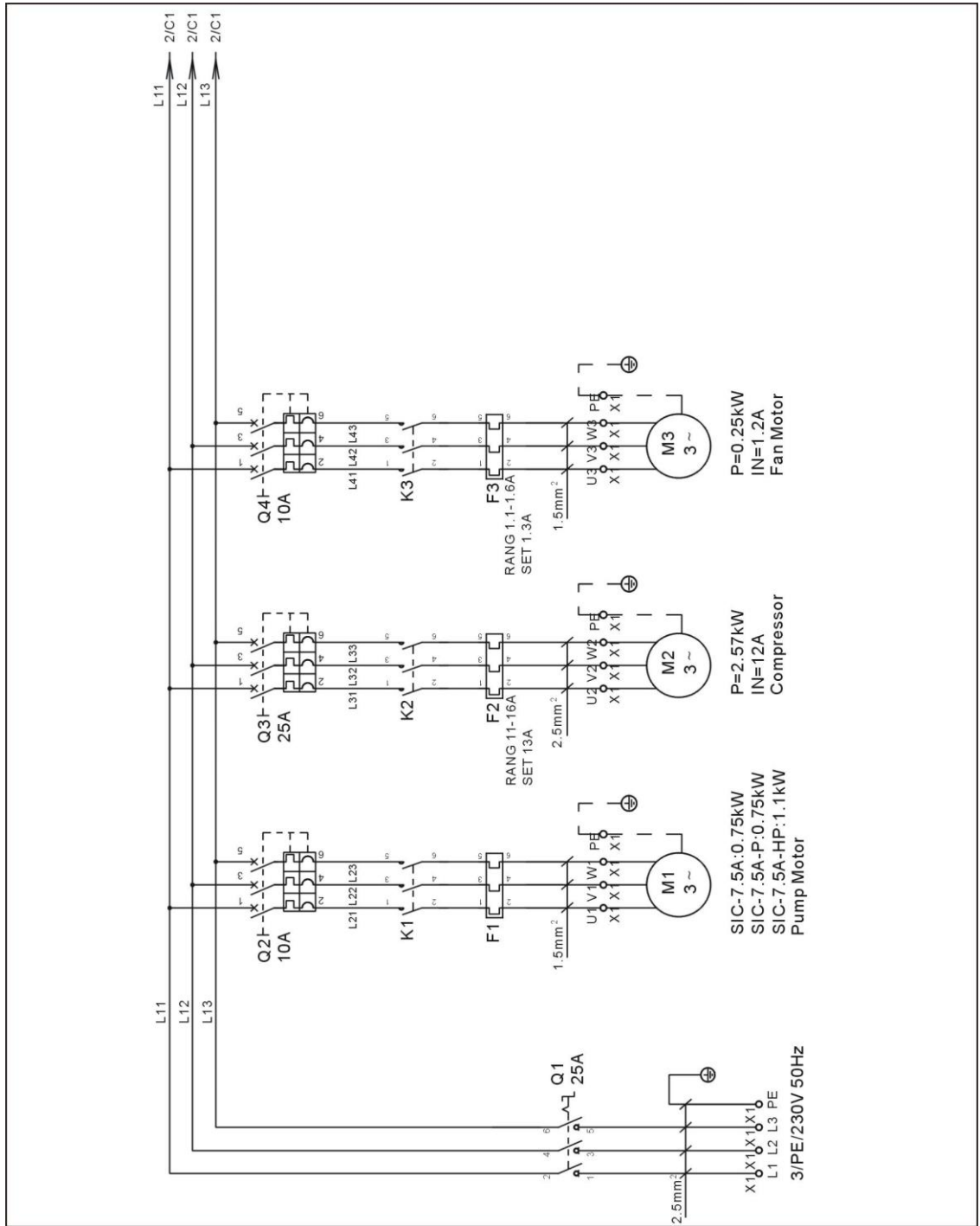

Picture 2-78: Main Electrical Circuit (SIC-7.5A-R2) (230V)

2.3.48 Control Circuit (SIC-7.5A-R2) (230V)

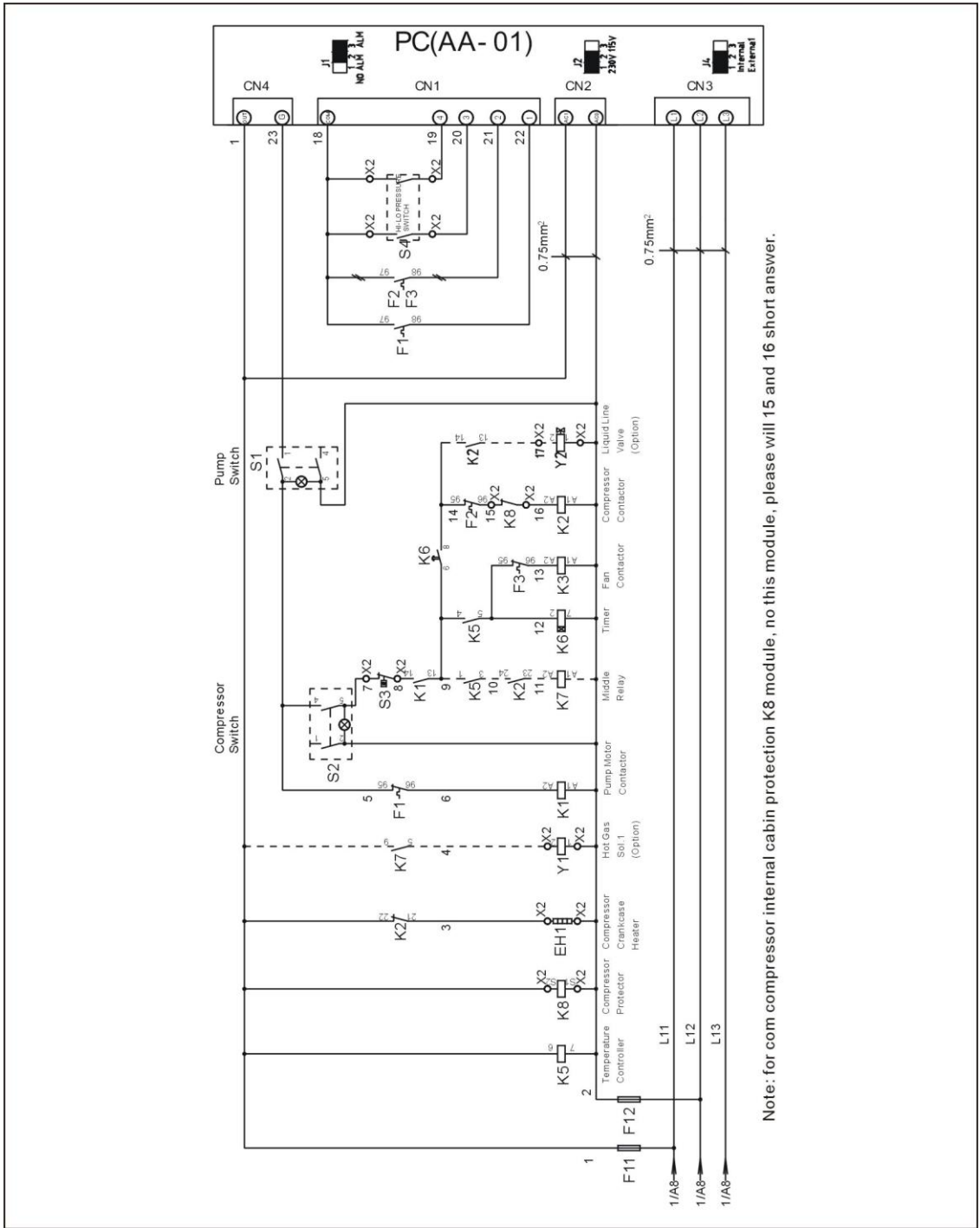

Note: for com compressor internal cabin protection K8 module, no this module, please will 15 and 16 short answer.

Picture 2-79: Control Circuit (SIC-7.5A-R2) (230V)

2.3.49 Electrical Components Layout (SIC-7.5A-R2) (230V)

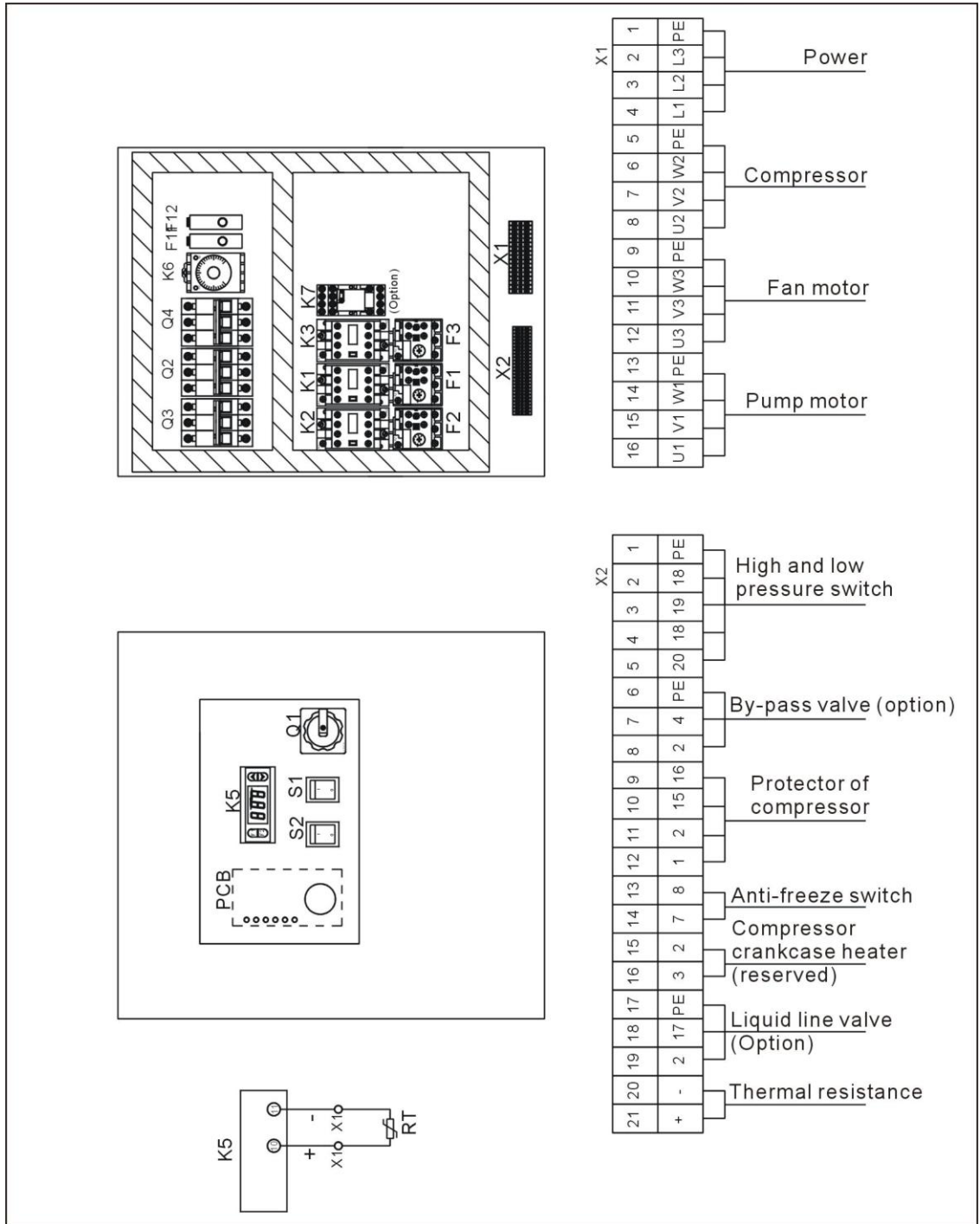

Picture 2-80: Electrical Components Layout (SIC-7.5A-R2) (230V)

2.3.50 Electrical Components List (SIC-7.5A-R2) (230V)

Table 2-44: Electrical Components List (SIC-7.5A-R2) (230V)

No.	Symbol	Name	Specificatons	Parts No.
1	Q1	Main switch	25A	YE10125250000
2	Q3	Circuit breaker *	25A	YE40602500000
3	Q2 Q4	Circuit breaker *	10A	YE40600300000
4	K1	Contactor *	220VAC 50/60Hz	-
5	K2	Contactor *	220VAC 50/60Hz	YE00602522000
6	-	Auciliary block	1NO	YE00691110000
7	K3	Contactor *	220VAC 50/60Hz	YE00601521000
8	K5	Temperature controller *	115~230VAC	YE85120200000
9	K6	Timer	3S-60M AC220V	YE86300300000
10	K7	Middle realy	AC220V	YE03270700000
11	F1	Overload relay *	-	-
12	F2	Overload relay *	11~16A	YE01260110000
13	F3	Overload relay *	1.1~1.6A	YE01160110000
14	F11 F12	Fuse**	2A	YE41001000000
15	S1 S2	Control switch *	250V~10(5)A 4P WH	YE10210400000
16	S3	Anti-frozen switch *	-	-
17	S4	HI-LO pressure switch	-	-
18	PCB	Control board *	230V 50/60Hz	YE80000100000
19	X1	Terminal board	-	YE61250040000
20	-	Terminal board	-	YE61253500000
21	X2	Terminal board	-	YE61250040000
22	-	Terminal board	-	YE61253500000
23	-	Terminal board	-	YE61250040000
24	-	Terminal board	-	YE61253500000
25	-	Terminal board	-	YE61250040000
26	-	Terminal board	-	YE61253500000
27	M1	Pump motor	230V 50/60Hz	-
28	M2	Compressor	230V 50/60Hz 2.57kW	-
29	M3	Fan motor	230V 50/60Hz 0.25kW	-
30	EH1	Compressor crankcase heater	230V 50/60Hz 45W	-
31	Y1	Solenoid valve**	230V 50/60Hz	-
32	Y2	Solenoid valve**	230V 50/60Hz	-

* means possible broken parts. ** means easy broken parts. Spare backup is suggested. Please confirm the version number of the manual before you order to ensure the stock

number and the parts are consistent.

2.3.54 Electrical Components List (SIC-12A-R2) (230V)

Table 2-45: Electrical Components List (SIC-12A-R2) (230V)

No.	Symbol	Name	Specificatons	Parts No.
1	Q1	Main switch	32A	YE10323200000
2	Q3	Circuit breaker *	40A	YE40604000000
3	Q2 Q4	Circuit breaker *	10A	YE40600300000
4	K1	Contactora *	220VAC 50/60Hz	-
5	K2	Contactora *	220VAC 50/60Hz	YE00602622000
6	-	Auciliary block	1NO	YE00691110000
7	K3	Contactora *	220VAC 50/60Hz	YE00601521000
8	K5	Temperature controller *	115~230VAC	YE85120200000
9	K6	Timer	3S-60M AC220V	YE86300300000
10	K7	Middle realy	AC220V	YE03270700000
11	F1	Overload relay *	-	-
12	F2	Overload relay *	17~22A	YE01260170000
13	F3	Overload relay *	1.4~2A	YE01160140000
14	F11 F12	Fuse**	2A	YE41001000000
15	S1 S2	Control switch *	250V~10(5)A 4P WH	YE10210400000
16	S3	Anti-frozen switch *	-	-
17	S4	HI-LO pressure switch	-	-
18	PCB	Control board *	230V 50/60Hz	YE80000100000
19	X1	Terminal board	-	YE61250040000
20	-	Terminal board	-	YE61253500000
21	-	Terminal board	-	YE61400010000
22	-	Terminal board	-	YE61403510000
23	X2	Terminal board	-	YE61250040000
24	-	Terminal board	-	YE61253500000
25	-		-	YE61250040000
26	-		-	YE61253500000
27	-		-	YE61250040000
28	-		-	YE61253500000
29	M1	Pump motor	230V 50/60Hz	-
30	M2	Compressor	230V 50/60Hz 3.68kW	-
31	M3	Fan motor	230V 50/60Hz 0.38kW	-
32	EH1	Compressor crankcase heater	230V 50/60Hz 45W	-
33	Y1	Solenoid valve**	230V 50/60Hz	-
34	Y2	Solenoid valve**	230V 50/60Hz	-

* means possible broken parts. ** means easy broken parts. Spare backup is suggested. Please confirm the version number of the manual before you order to ensure the stock number and the parts are consistent.

2.3.55 Main Electrical Circuit (SIC-18A-R2) (230V)

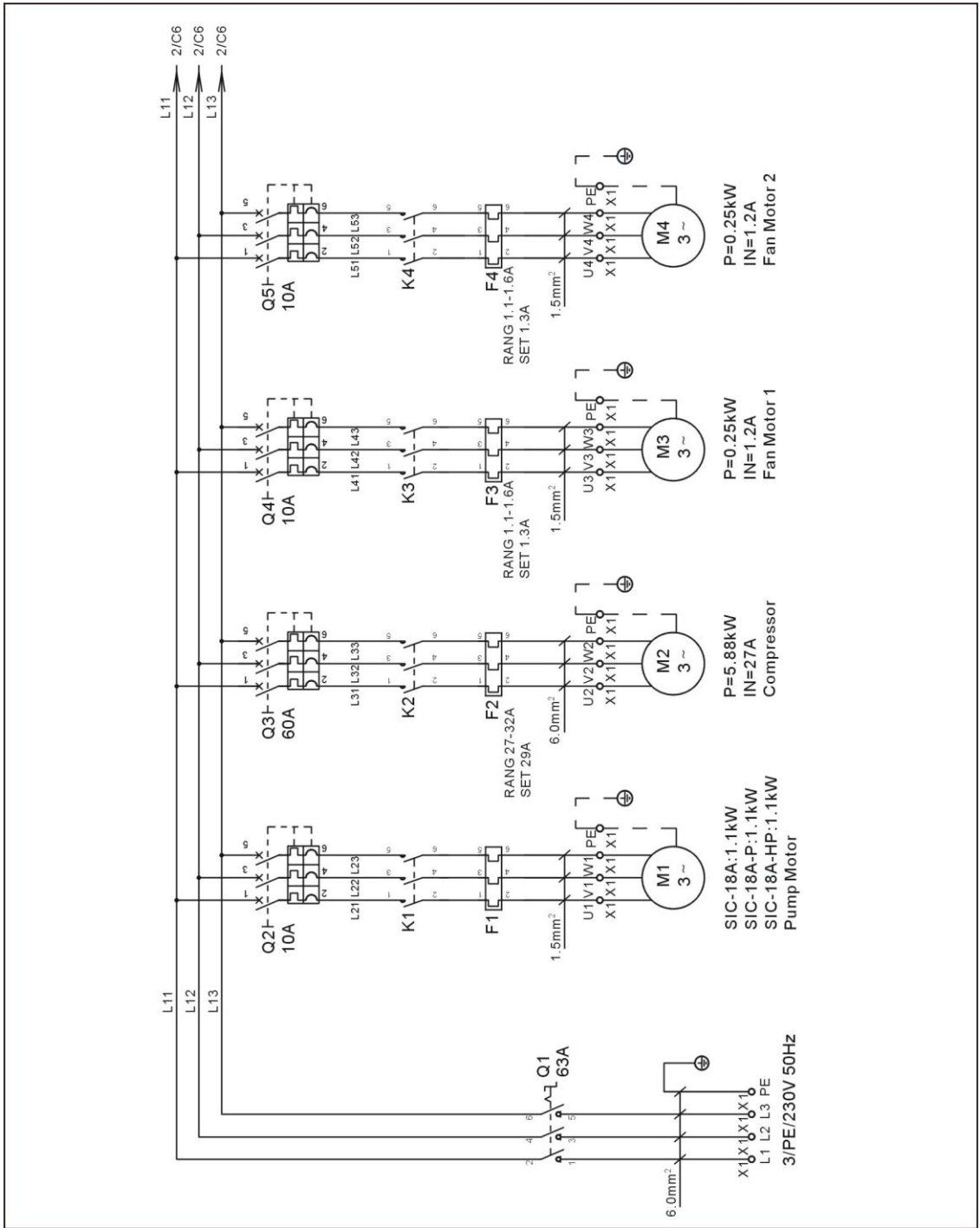

Picture 2-84: Main Electrical Circuit (SIC-18A-R2) (230V)

2.3.56 Control Circuit (SIC-18A-R2) (230V)

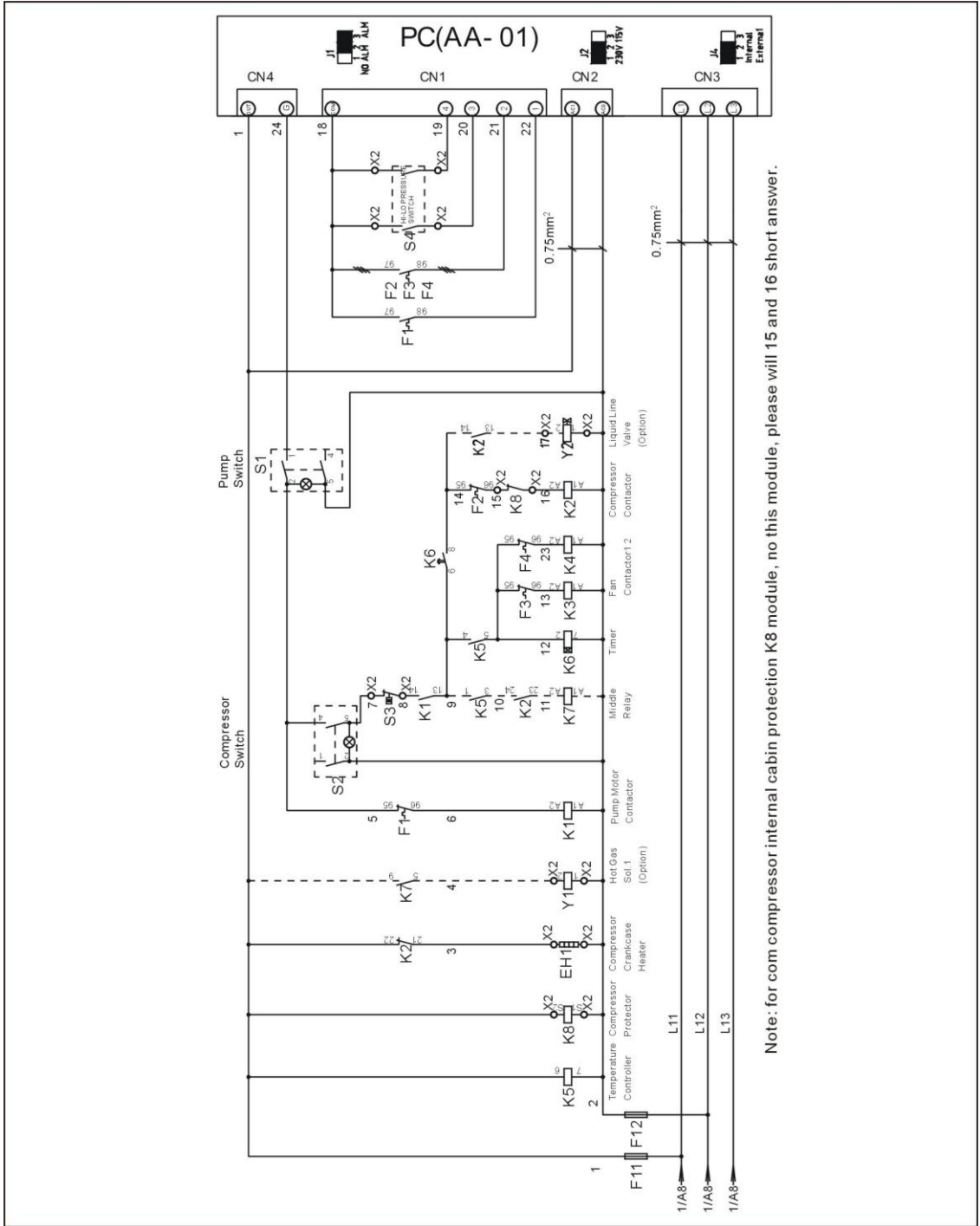

Note: for com compressor internal cabin protection K8 module, no this module, please will 15 and 16 short answer.

Picture 2-85: Control Circuit (SIC-18A-R2) (230V)

2.3.57 Electrical Components Layout (SIC-18A-R2) (230V)

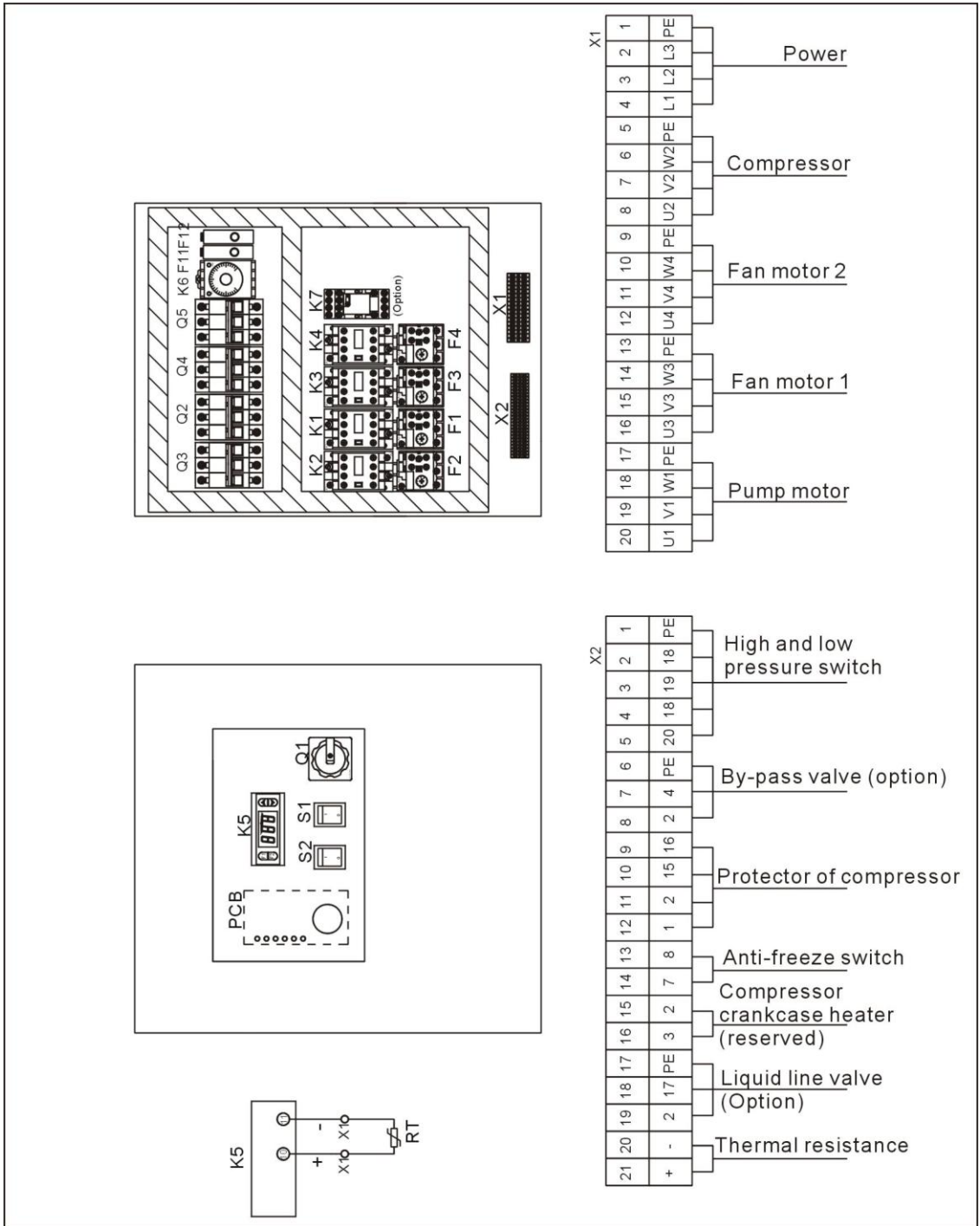

Picture 2-86: Electrical Components Layout (SIC-18A-R2) (230V)

2.3.58 Electrical Components List (SIC-18A-R2) (230V)

Table 2-46: Electrical Components List (SIC-18A-R2) (230V)

No.	Symbol	Name	Specificatons	Parts No.
1	Q1	Main switch	63A	YE10636300000
2	Q3	Circuit breaker *	60A	YE40606000000
3	Q2 Q4 Q5	Circuit breaker *	10A	YE40600300000
4	K1	Contactor *	220VAC 50/60Hz	-
5	K2	Contactor *	220VAC 50/60Hz	YE00602722000
6	-	Auxiliary block	1NO	YE00691110000
7	K3 K4	Contactor *	220VAC 50/60Hz	YE00601521000
8	K5	Temperature controller *	115~230VAC	YE85120200000
9	K6	Timer	3S-60M AC220V	YE86300300000
10	K7	Middle realy	AC220V	YE03270700000
11	F1	Overload relay *	-	-
12	F2	Overload relay *	27~32A	YE01612600600
13	F3 F4	Overload relay *	1.1~1.6A	YE01160110000
14	F11 F12	Fuse**	2A	YE41001000000
15	S1 S2	Control switch *	250V~10(5)A 4P WH	YE10210400000
16	S3	Anti-frozen switch *	-	-
17	S4	HI-LO pressure switch	-	-
18	PCB	Control board *	230V 50/60Hz	YE80000100000
19	X1	Terminal board	-	YE61250040000
20	-	Terminal board	-	YE61253500000
21	-	Terminal board	-	YE61060000000
22	-	Terminal board	-	YE61063500000
23	X2	Terminal board	-	YE61250040000
24	-	Terminal board	-	YE61253500000
25	-	Terminal board	-	YE61250040000
26	-	Terminal board	-	YE61253500000
27	-	Terminal board	-	YE61250040000
28	-	Terminal board	-	YE61253500000
29	M1	Pump motor	230V 50/60Hz	-
30	M2	Compressor	230V 50/60Hz 5.88kW	-
31	M3 M4	Fan motor	230V 50/60Hz 0.25kW	-
32	EH1	Compressor crankcase heater	230V 50/60Hz 45W	-
33	Y1	Solenoid valve**	230V 50/60Hz	-
34	Y2	Solenoid valve**	230V 50/60Hz	-

* means possible broken parts. ** means easy broken parts. Spare backup is suggested. Please confirm the version number of the manual before you order to ensure the stock number and the parts are consistent.

2.3.59 Main Electrical Circuit (SIC-24A-R2) (230V)

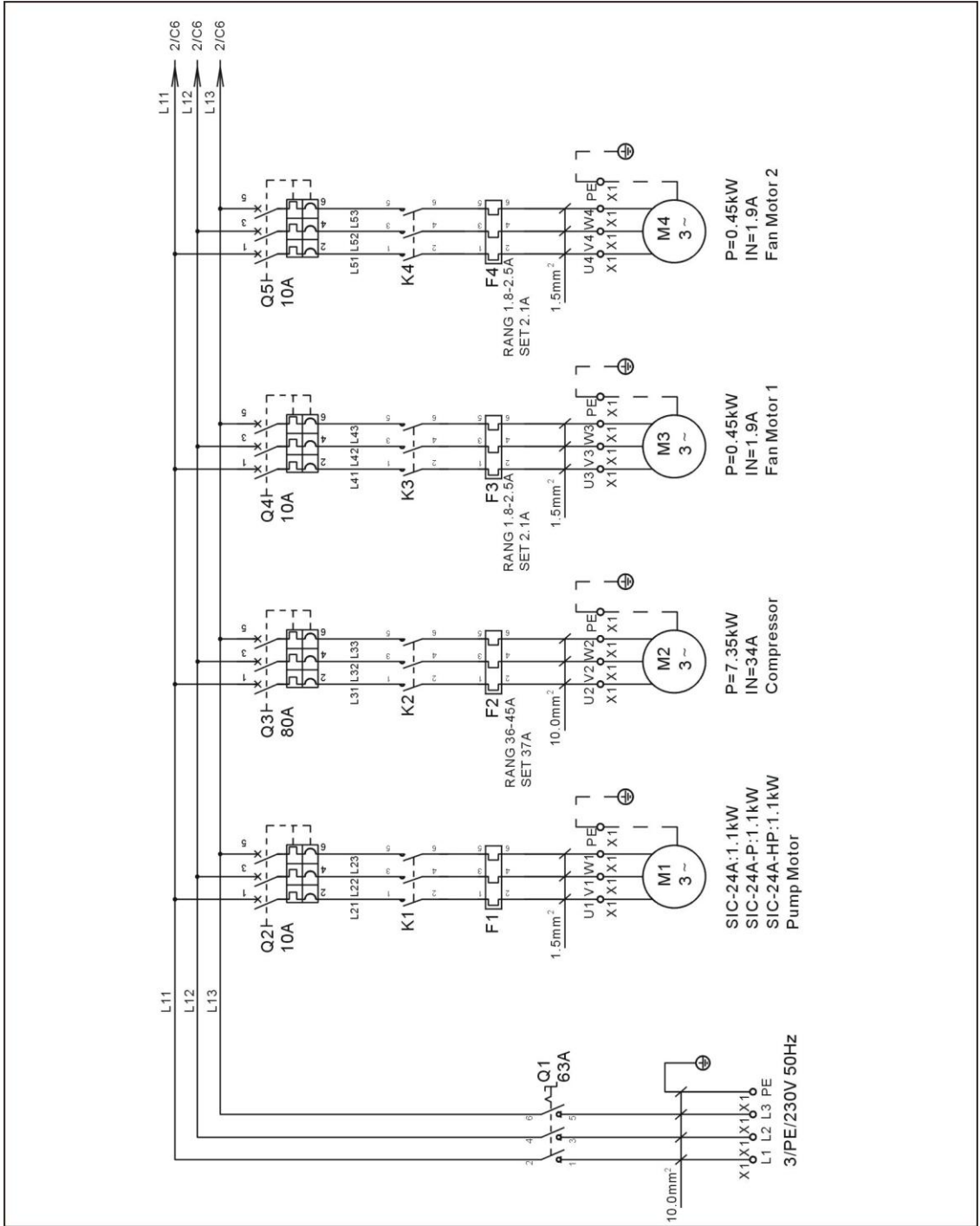

Picture 2-87: Main Electrical Circuit (SIC-24A-R2) (230V)

2.3.60 Control Circuit (SIC-24A-R2) (230V)

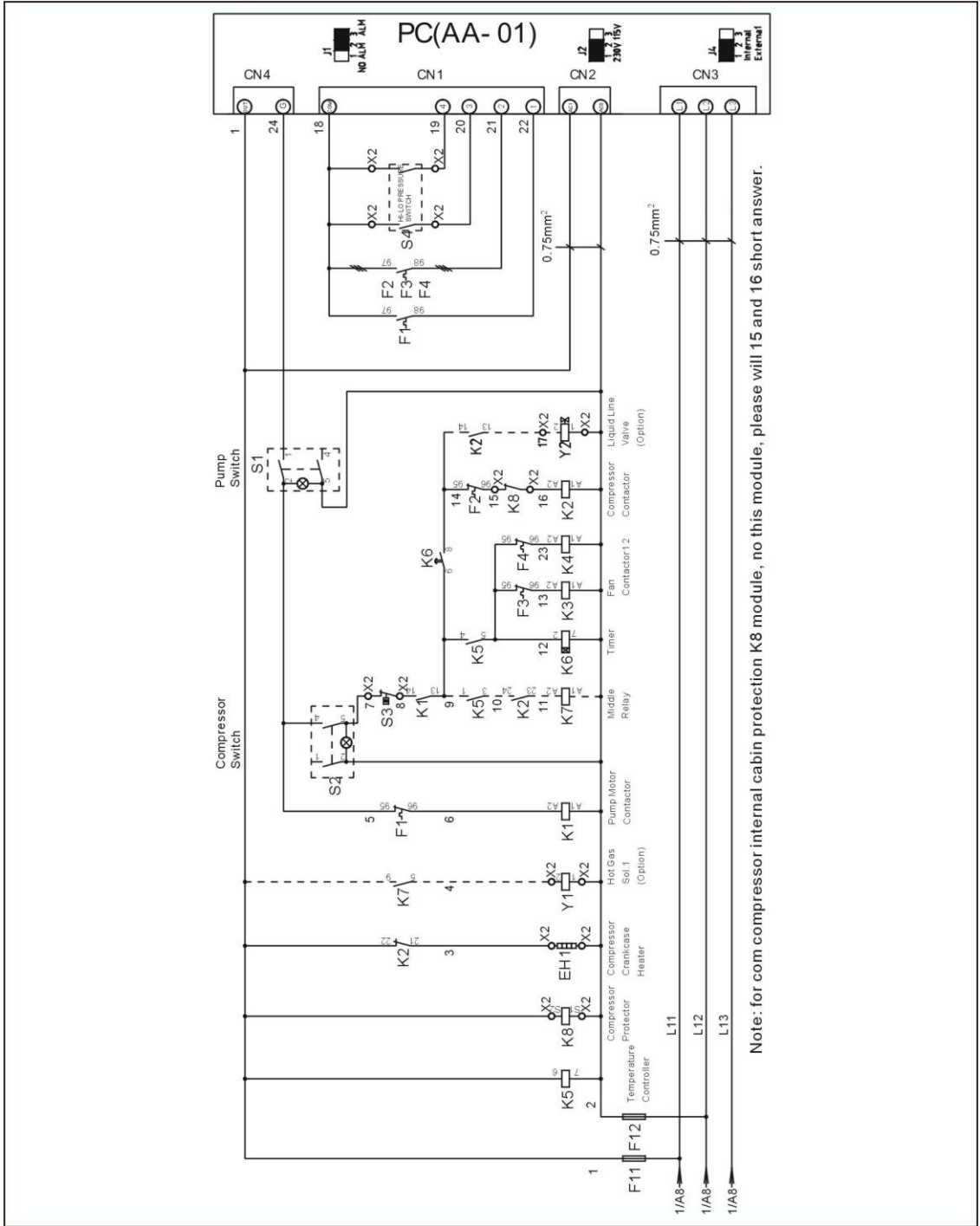

Picture 2-88: Control Circuit (SIC-24A-R2) (230V)

2.3.61 Electrical Components Layout (SIC-24A-R2) (230V)

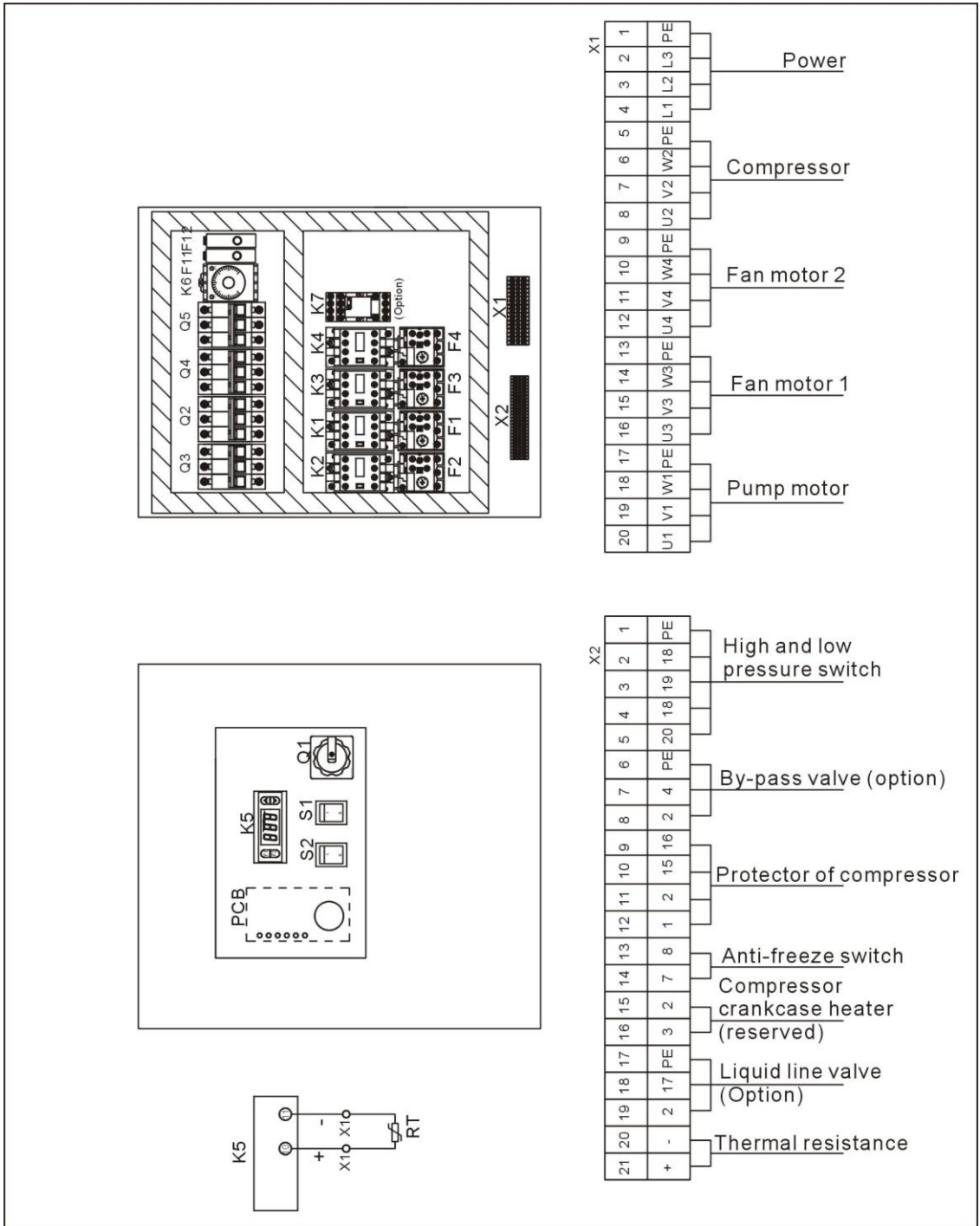

Picture 2-89: Electrical Components Layout (SIC-24A-R2) (230V)

2.3.62 Electrical Components List (SIC-24A-R2) (230V)

Table 2-47: Electrical Components List (SIC-24A-R2) (230V)

No.	Symbol	Name	Specificatons	Parts No.
1	Q1	Main switch	63A	YE10636300000
2	Q3	Circuit breaker *	80A	YE40800300000
3	Q2 Q4 Q5	Circuit breaker *	10A	YE40600300000
4	K1	Contactoer *	220VAC 50/60Hz	-
5	K2	Contactoer *	220VAC 50/60Hz	YE00503500000
6	-	Auxiliary block	1NC	YE00592110100
7	-	Auxiliary block	1NO	YE00592110000
8	-	Auxiliary block	1NO	YE00592110000
9	K3 K4	Contactoer *	220VAC 50/60Hz	YE00601521000
10	K5	Temperature controller *	115~230VAC	YE85120200000
11	K6	Timer	3S-60M AC220V	YE86300300000
12	K7	Middle realy	AC220V	YE03270700000
13	F1	Overload relay *	-	-
14	F2	Overload relay *	36~45A	YE01612660000
15	F3 F4	Overload relay *	1.8~2.5A	YE01160180000
16	F11 F12	Fuse**	2A	YE41001000000
17	S1 S2	Control switch *	250V~10(5)A 4P WH	YE10210400000
18	S3	Anti-frozen switch *	-	-
19	S4	HI-LO pressure switch	-	-
20	PCB	Control board *	230V 50/60Hz	YE80000100000
21	X1	Terminal board	-	YE61250040000
22	-	Terminal board	-	YE61253500000
23	-	Terminal board	-	YE61100000000
24	-	Terminal board	-	YE61103500000
25	X2	Terminal board	-	YE61250040000
26	-	Terminal board	-	YE61253500000
27	-	Terminal board	-	YE61250040000
28	-	Terminal board	-	YE61253500000
29	-	Terminal board	-	YE61250040000
30	-	Terminal board	-	YE61253500000
31	M1	Pump motor	230V 50/60Hz	-
32	M2	Compressor	230V 50/60Hz 7.35kW	-
33	M3 M4	Fan motor	230V 50/60Hz 0.45kW	-
34	EH1	Compressor crankcase heater	230V 50/60Hz 45W	-
35	Y1	Solenoid valve**	230V 50/60Hz	-
36	Y2	Solenoid valve**	230V 50/60Hz	-

* means possible broken parts. ** means easy broken parts. Spare backup is suggested. Please confirm the version number of the manual before you order to ensure the stock

number and the parts are consistent.

2.3.63 Main Electrical Circuit (SIC-28A-R2) (230V)

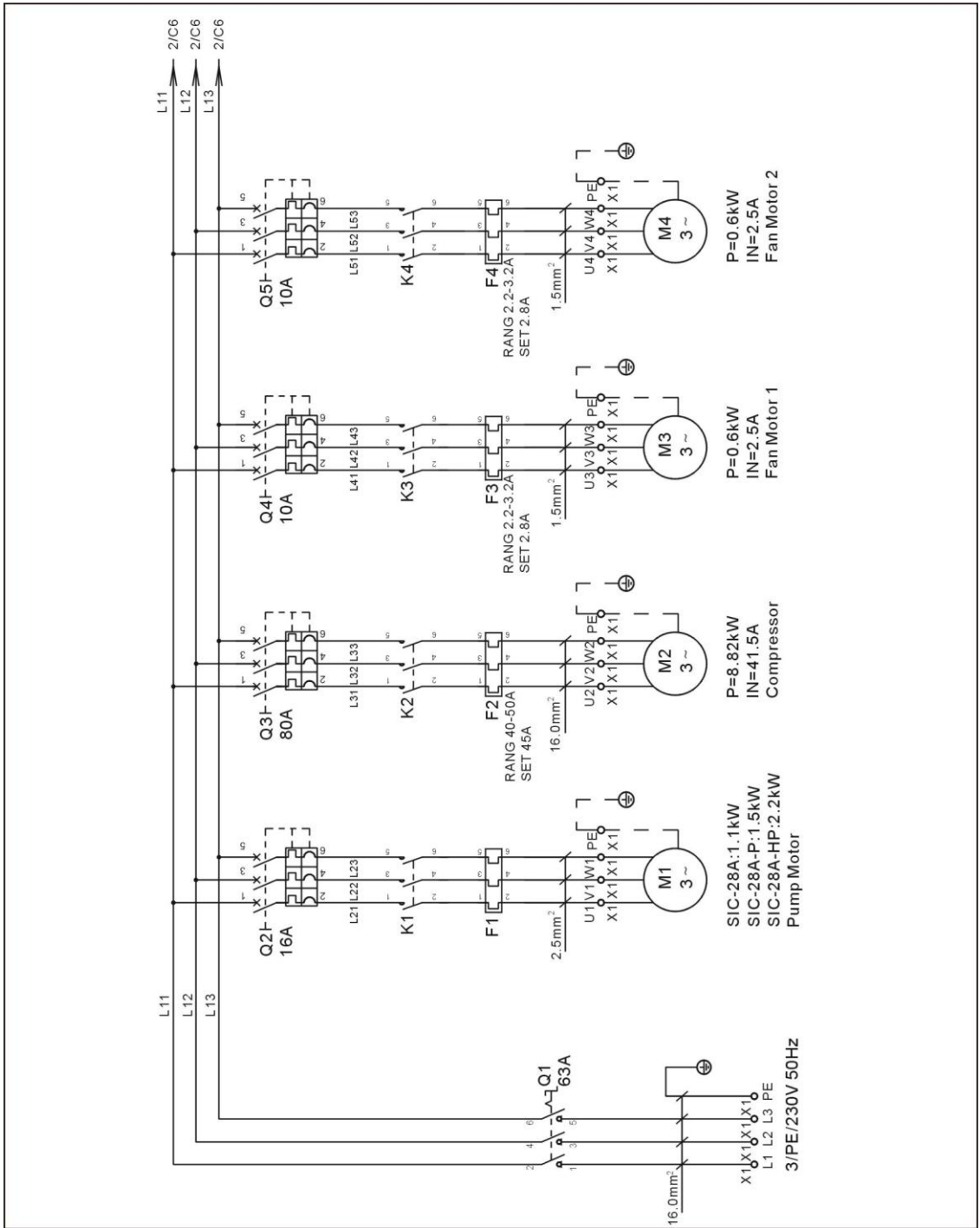

Picture 2-90: Main Electrical Circuit (SIC-28A-R2) (230V)

2.3.64 Control Circuit (SIC-28A-R2) (230V)

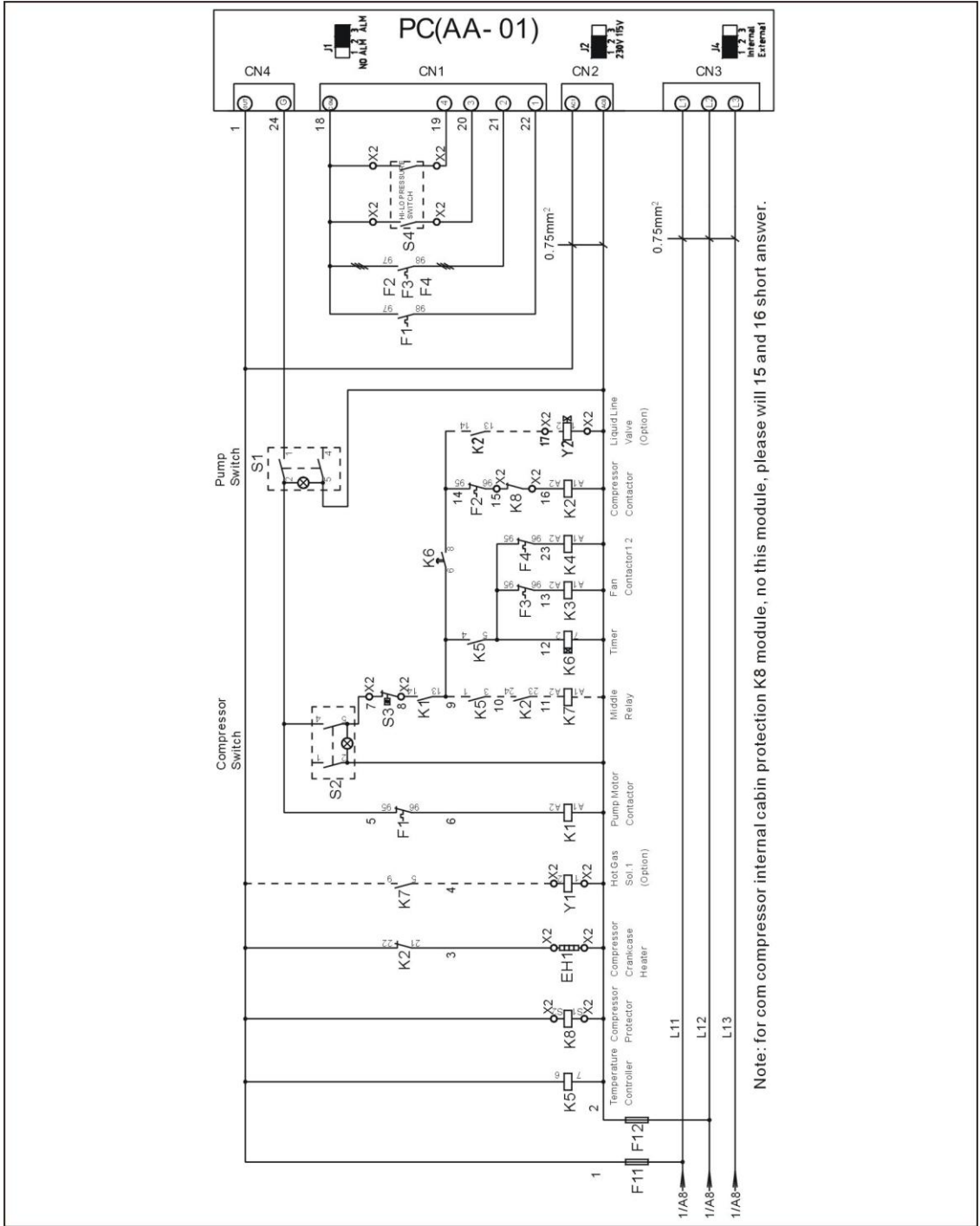

Picture 2-91: Control Circuit (SIC-28A-R2) (230V)

2.3.65 Electrical Components Layout (SIC-28A-R2) (230V)

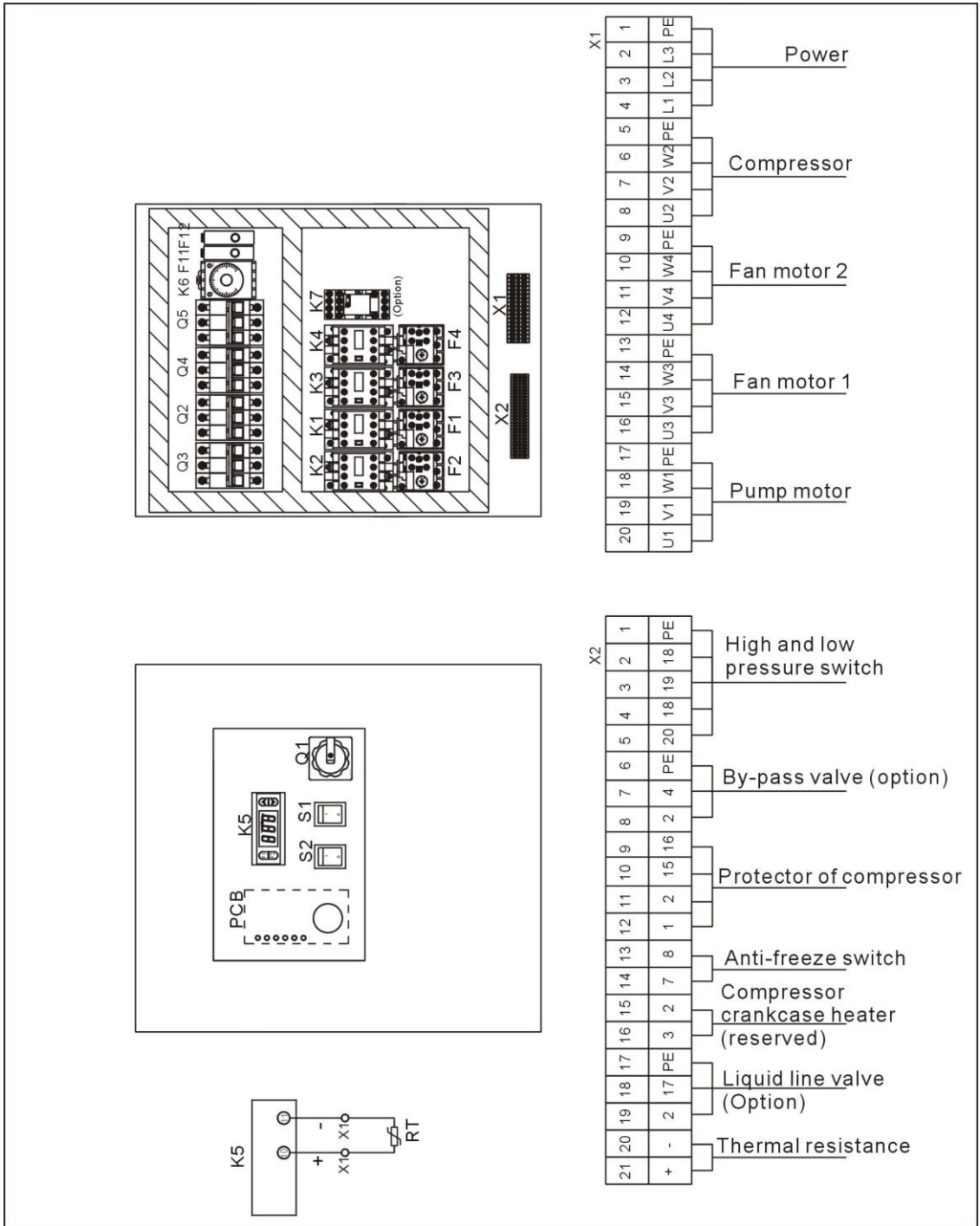

Picture 2-92: Electrical Components Layout (SIC-28A-R2) (230V)

2.3.66 Electrical Components List (SIC-28A-R2) (230V)

Table 2-48: Electrical Components List (SIC-28A-R2) (230V)

No.	Symbol	Name	Specificatons	Parts No.
1	Q1	Main switch	63A	YE10636300000
2	Q3	Circuit breaker *	80A	YE40800300000
3	Q2	Circuit breaker *	16A	YE40601500000
4	Q4 Q5	Circuit breaker *	10A	YE40600300000
5	K1	Contactor *	220VAC 50/60Hz	-
6	K2	Contactor *	220VAC 50/60Hz	YE00503600000
7	-	Auxiliary block	1NC	YE00592110100
8	-	Auxiliary block	1NO	YE00592110000
9	-	Auxiliary block	1NO	YE00592110000
10	K3 K4	Contactor *	220VAC 50/60Hz	YE00601521000
11	K5	Temperature controller *	115~230VAC	YE85120200000
12	K6	Timer	3S-60M AC220V	YE86300300000
13	K7	Middle realy	AC220V	YE03270700000
14	F1	Overload relay *	-	-
15	F2	Overload relay *	40~50A	YE01513600900
16	F3 F4	Overload relay *	1.8~2.5A	YE01160180000
17	F11	Fuse**	2A	YE41001000000
18	S1 S2	Control switch *	250V~10(5)A 4P WH	YE10210400000
19	S3	Anti-frozen switch *	-	-
20	S4	HI-LO pressure switch	-	-
21	PCB	Control board *	230V 50/60Hz	YE80000100000
22	X1	Terminal board	-	YE61250040000
23	-	Terminal board	-	YE61253500000
24	-	Terminal board	-	YE61160000000
25	-	Terminal board	-	YE61163500000
26	X2	Terminal board	-	YE61250040000
27	-	Terminal board	-	YE61253500000
28	-	Terminal board	-	YE61250040000
29	-	Terminal board	-	YE61253500000
30	-	Terminal board	-	YE61250040000
31	-	Terminal board	-	YE61253500000
32	M1	Pump motor	230V 50/60Hz	-
33	M2	Compressor	230V 50/60Hz 8.82kW	-
34	M3 M4	Fan motor	230V 50/60Hz 0.6kW	-
35	EH1	Compressor crankcase heater	230V 50/60Hz 45W	-
36	Y1	Solenoid valve**	230V 50/60Hz	-
37	Y2	Solenoid valve**	230V 50/60Hz	-

* means possible broken parts. ** means easy broken parts. Spare backup is suggested. Please confirm the version number of the manual before you order to ensure the stock number and the parts are consistent.

2.3.67 Main Electrical Circuit (SIC-38A-R2) (230V)

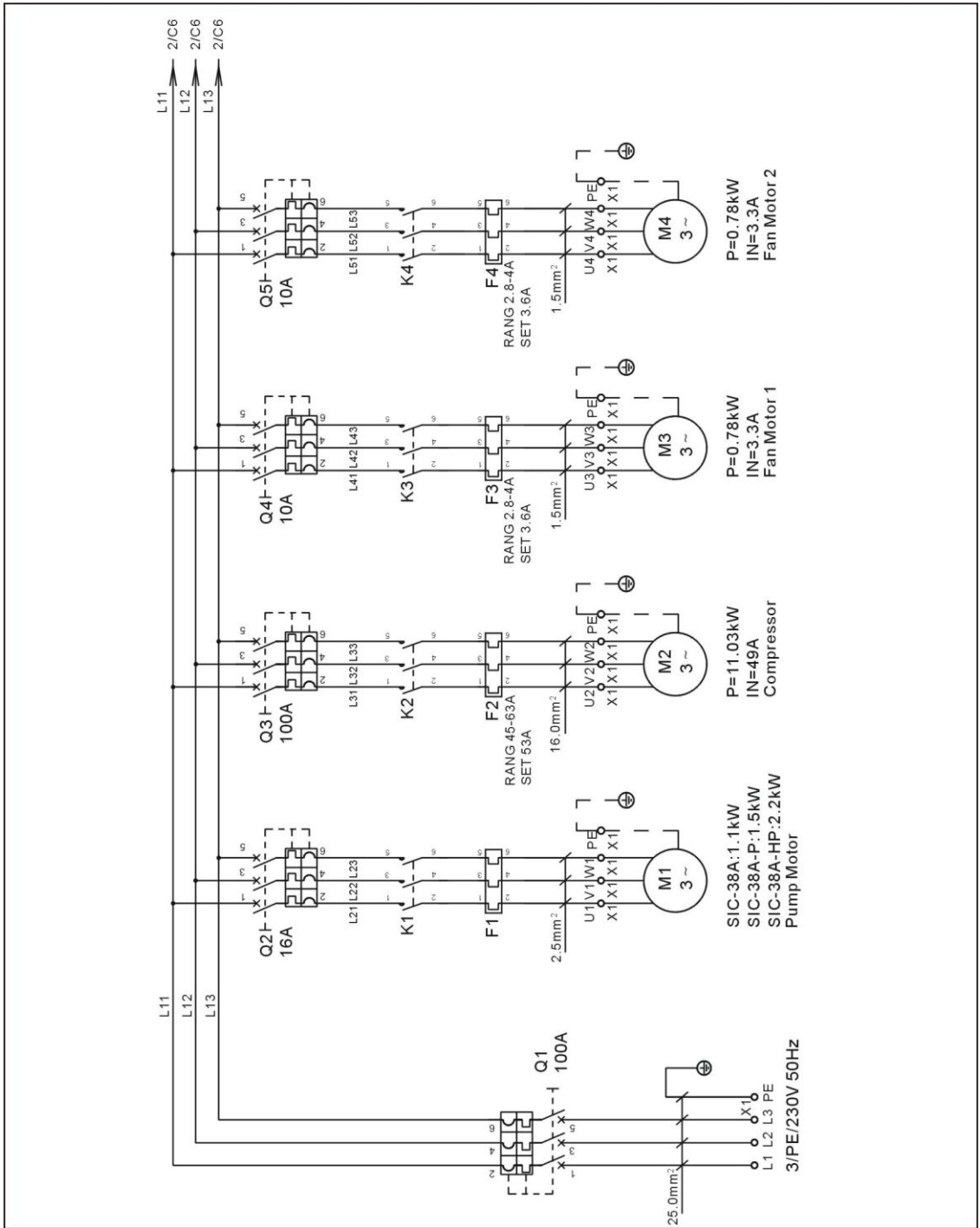

Picture 2-93: Main Electrical Circuit (SIC-38A-R2) (230V)

2.3.68 Control Circuit (SIC-38A-R2) (230V)

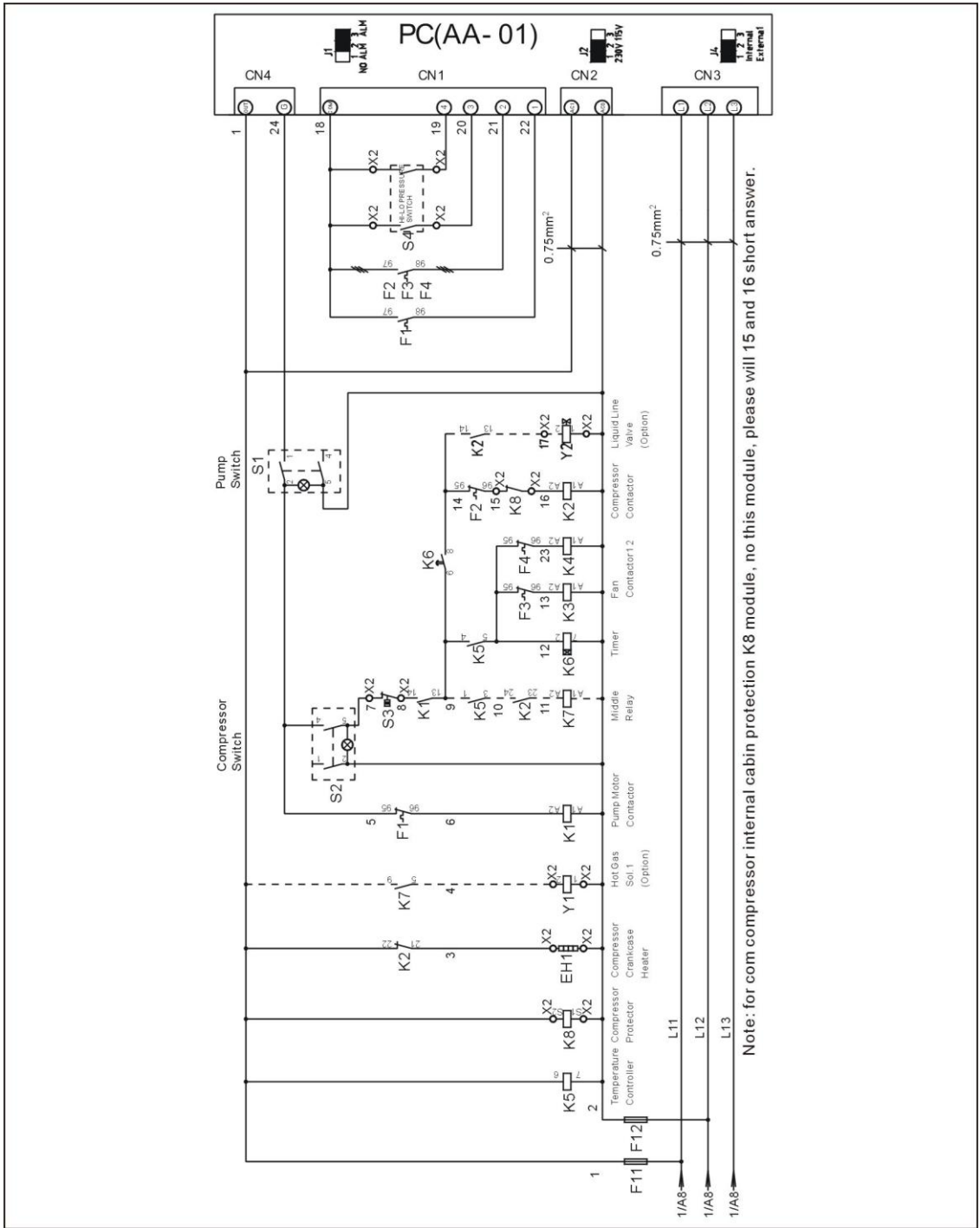

Picture 2-94: Control Circuit (SIC-38A-R2) (230V)

2.3.69 Electrical Components Layout (SIC-38A-R2) (230V)

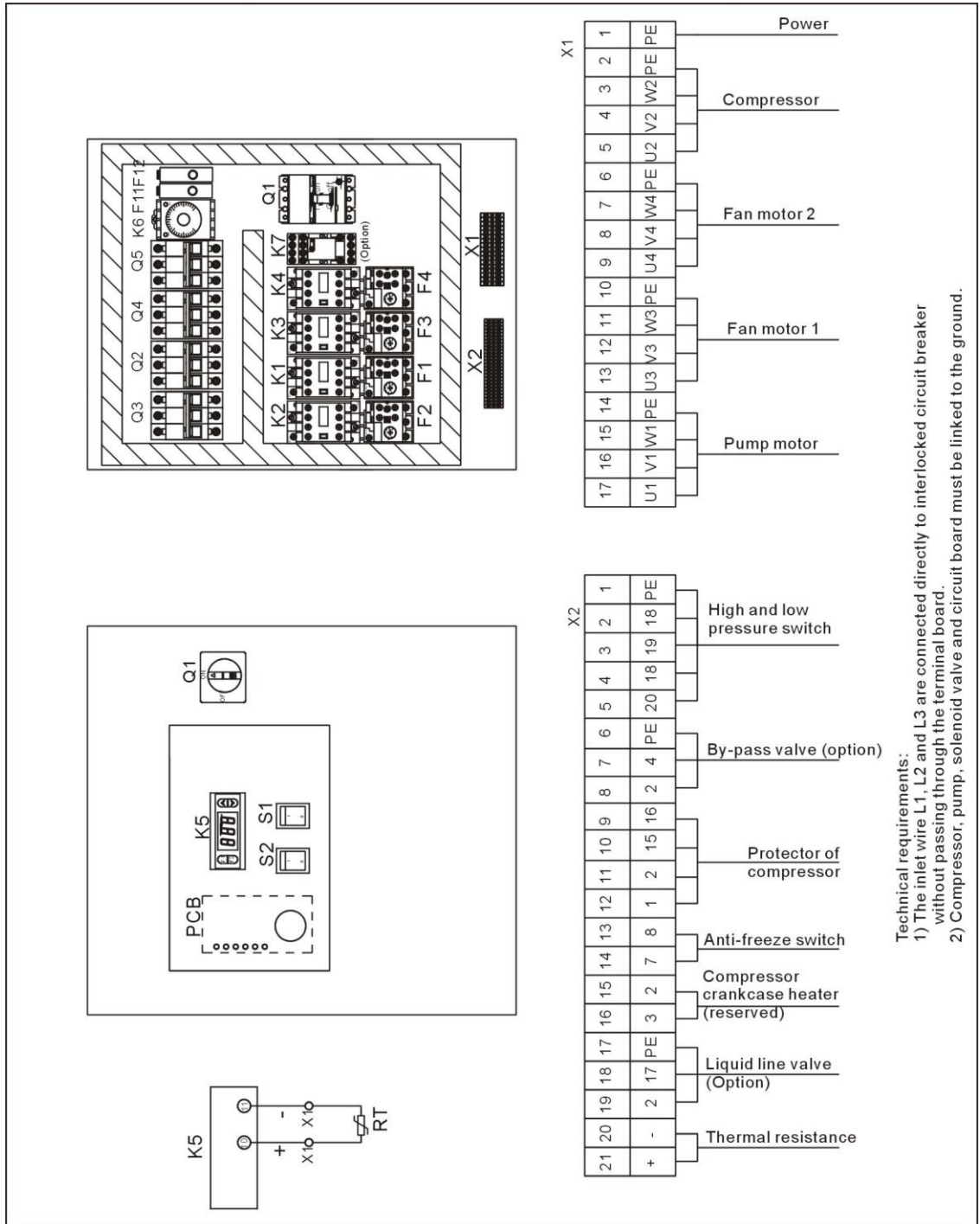

Picture 2-95: Electrical Components Layout (SIC-38A-R2) (230V)

2.3.70 Electrical Components List (SIC-38A-R2) (230V)

Table 2-49: Electrical Components List (SIC-38A-R2) (230V)

No.	Symbol	Name	Specifications	Parts No.
1	Q1	Circuit breaker *	100A	YE41110000000
2	Q3	Circuit breaker *	100A	YE40100300000
3	Q2	Circuit breaker *	16A	YE40601500000
4	Q4 Q5	Circuit breaker *	10A	YE40600300000
5	K1	Contactor *	220VAC 50/60Hz	-
6	K2	Contactor *	220VAC 50/60Hz	YE00504400000
7	-	Auxiliary block	1NC	YE00592110100
8	-	Auxiliary block	1NO	YE00592110000
9	-	Auxiliary block	1NO	YE00592110000
10	K3 K4	Contactor *	220VAC 50/60Hz	YE00601521000
11	K5	Temperature controller *	115~230VAC	YE85120200000
12	K6	Timer	3S-60M AC220V	YE86300300000
13	K7	Middle realy	AC220V	YE03270700000
14	F1	Overload relay *	-	-
15	F2	Overload relay *	45~63A	YE01514640000
16	F3 F4	Overload relay *	2.8~4A	YE01160280000
17	F11 F12	Fuse**	2A	YE41001000000
18	S1 S2	Control switch *	250V~10(5)A 4P WH	YE10210400000
19	S3	Anti-frozen switch *	-	-
20	S4	HI-LO pressure switch	-	-
21	PCB	Control board *	230V 50/60Hz	YE80000100000
22	X1	Terminal board	-	YE61253500000
23	-	Terminal board	-	YE61160000000
24	-	Terminal board	-	YE61163500000
25	-	Terminal board	-	YE61250040000
26	-	Terminal board	-	YE61253500000
27	X2	Terminal board	-	YE61250040000
28	-	Terminal board	-	YE61253500000
29	-	Terminal board	-	YE61250040000
30	-	Terminal board	-	YE61253500000
31	-	Terminal board	-	YE61250040000
32	-	Terminal board	-	YE61253500000
33	M1	Pump motor	230V 50/60Hz	-
34	M2	Compressor	230V 50/60Hz 11.03kW	-
35	M3 M4	Fan motor	230V 50/60Hz 0.78kW	-
36	EH1	Compressor crankcase heater	230V 50/60Hz 45W	-
37	Y1	Solenoid valve**	230V 50/60Hz	-
38	Y2	Solenoid valve**	230V 50/60Hz	-

* means possible broken parts. ** means easy broken parts. Spare backup is suggested. Please confirm the version number of the manual before you order to ensure the stock

number and the parts are consistent.

2.3.71 Main Electrical Circuit (SIC-48A-R2) (230V)

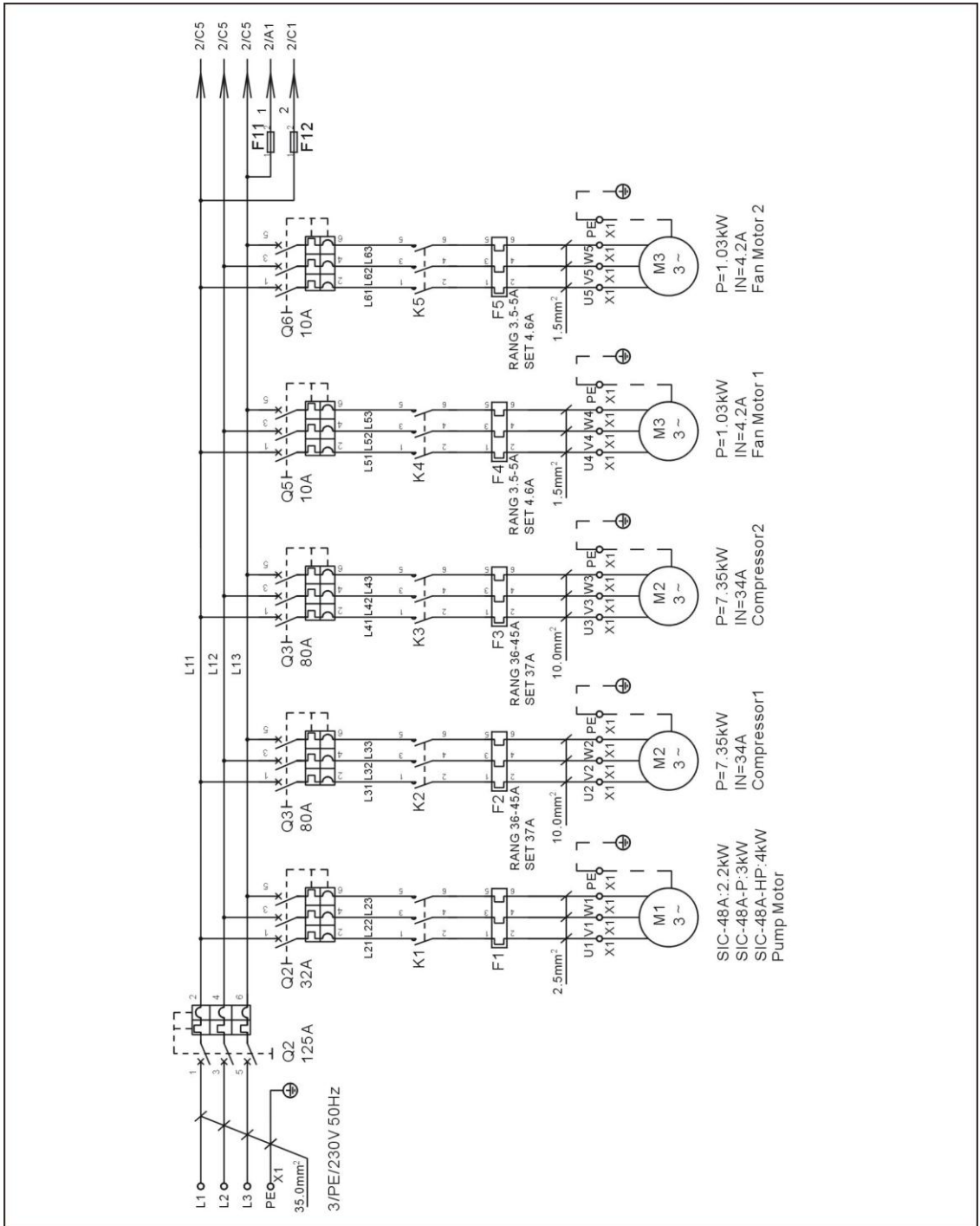

Picture 2-96: Main Electrical Circuit (SIC-48A-R2) (230V)

2.3.72 Control Circuit (SIC-48A-R2) (230V)

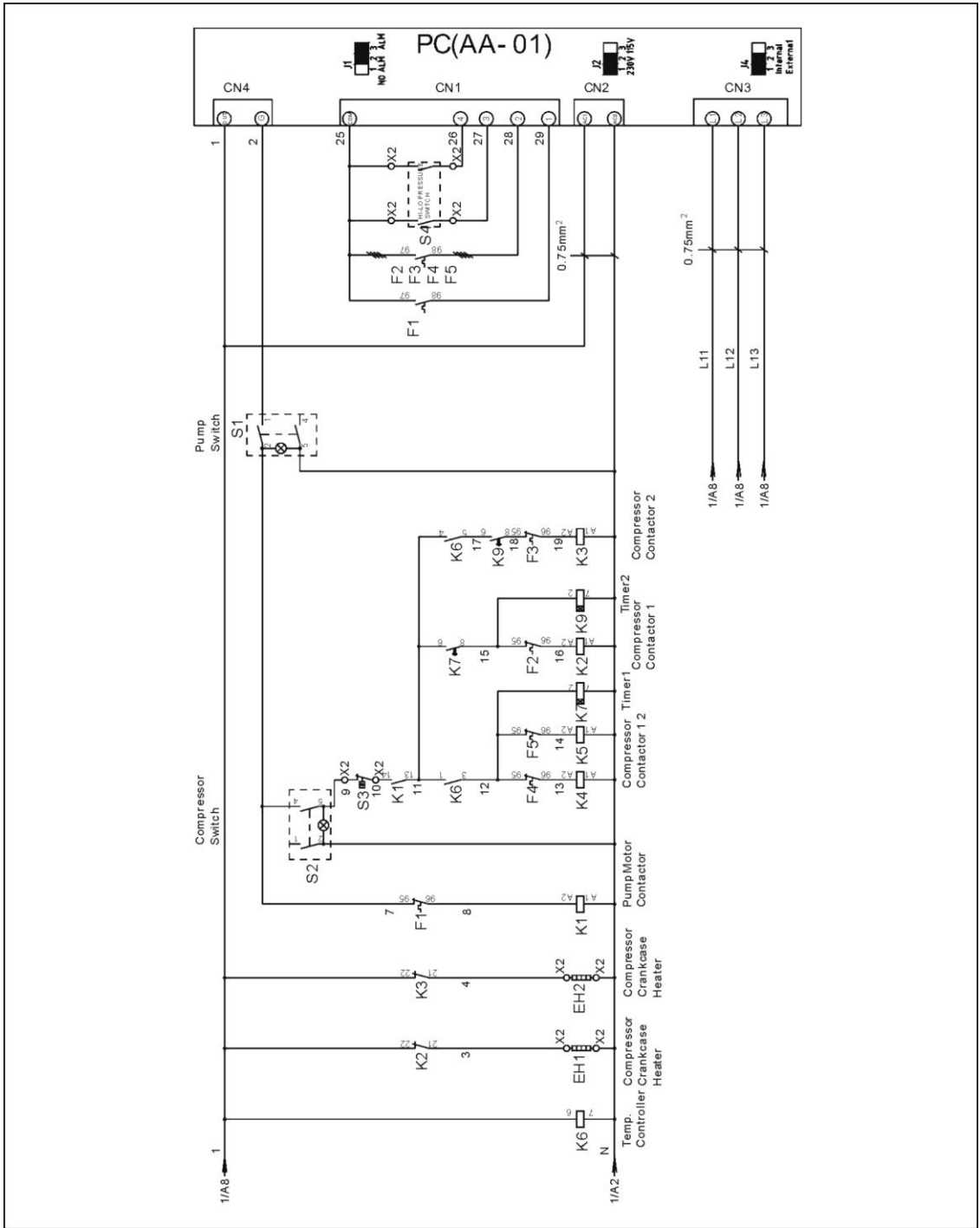

Picture 2-97: Control Circuit (SIC-48A-R2) (230V)

2.3.73 Electrical Components Layout (SIC-48A-R2) (230V)

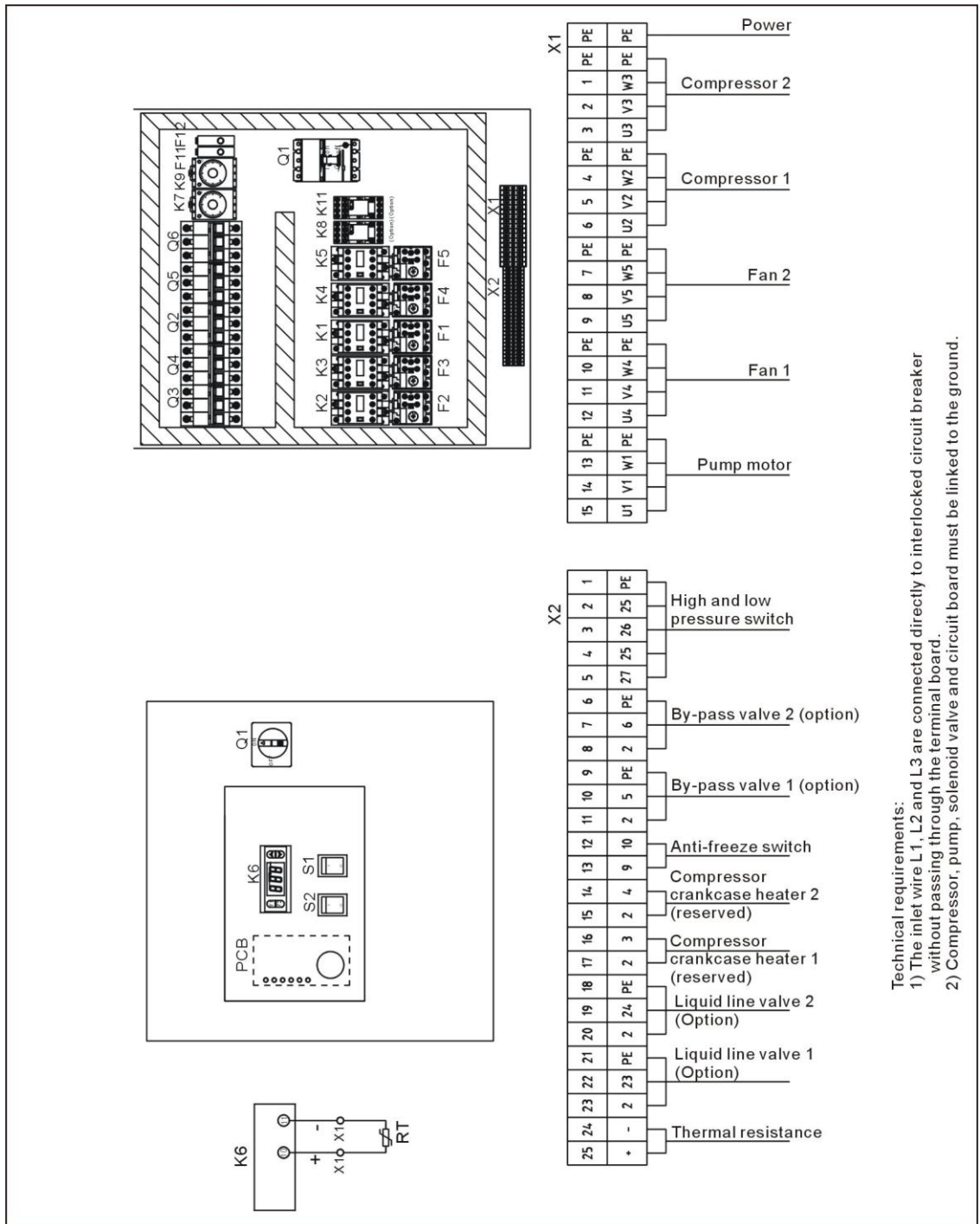

Picture 2-98: Electrical Components Layout (SIC-48A-R2) (230V)

2.3.74 Electrical Components List (SIC-48A-R2) (230V)

Table 2-50: Electrical Components List (SIC-48A-R2) (230V)

No.	Symbol	Name	Specificatons	Parts No.
1	Q1	Circuit breaker *	125A	YE41161200000
2	Q2	Circuit breaker *	32A	YE40603200000
3	Q3 Q4	Circuit breaker *	80A	YE40800300000
4	Q4 Q5	Circuit breaker *	10A	YE40600300000
5	K1	Contactora *	220VAC 50/60Hz	-
6	K2 K3	Contactora *	220VAC 50/60Hz	YE00503500000
7	-	Auxiliary block	1NC	YE00592110100
8	-	Auxiliary block	1NO	YE00592110000
9	-	Auxiliary block	1NO	YE00592110000
10	-	Auxiliary block	1NO	YE00592110000
11	K4 K5	Contactora *	220VAC 50/60Hz	YE00601521000
12	K6	Temperature controller *	115~230VAC	YE85120200000
13	K7 K9	Timer	3S-60M AC220V	YE86300300000
14	K8 K11	Middle realy	AC220V	YE03270700000
15	F1	Overload relay *	-	-
16	F2 F3	Overload relay *	36~45A	YE01612660000
17	F4 F5	Overload relay *	3.5~5A	YE01160350000
18	F11 F12	Fuse**	2A	YE41001000000
19	S1 S2	Control switch *	250V~10(5)A 4P WH	YE10210400000
20	S3	Anti-frozen switch *	-	-
21	S4	HI-LO pressure switch	-	-
22	PCB	Control board *	230V 50/60Hz	YE80000100000
23	X1	Terminal board	-	YE61353500000
24	-	Terminal board	-	YE61100000000
25	-	Terminal board	-	YE61103500000
26	-	Terminal board	-	YE61250040000
27	-	Terminal board	-	YE61253500000
28	X2	Terminal board	-	YE61250040000
29	-	Terminal board	-	YE61253500000
30	-	Terminal board	-	YE61250040000
31	-	Terminal board	-	YE61253500000
32	-	Terminal board	-	YE61250040000
33	-	Terminal board	-	YE61253500000
34	M1	Pump motor	230V 50/60Hz	-
35	M2 M3	Compressor	230V 50/60Hz 7.35kW	-
36	M4 M5	Fan motor	230V 50/60Hz 1.03kW	-
37	EH1	Compressor crankcase heater	230V 50/60Hz	-
38	Y1 Y2	Solenoid valve**	230V 50/60Hz	-
39	Y3 Y4	Solenoid valve**	230V 50/60Hz	-

* means possible broken parts. ** means easy broken parts. Spare backup is suggested.



Please confirm the version number of the manual before you order to ensure the stock number and the parts are consistent.

2.3.75 Main Electrical Circuit (SIC-58A-R2) (230V)

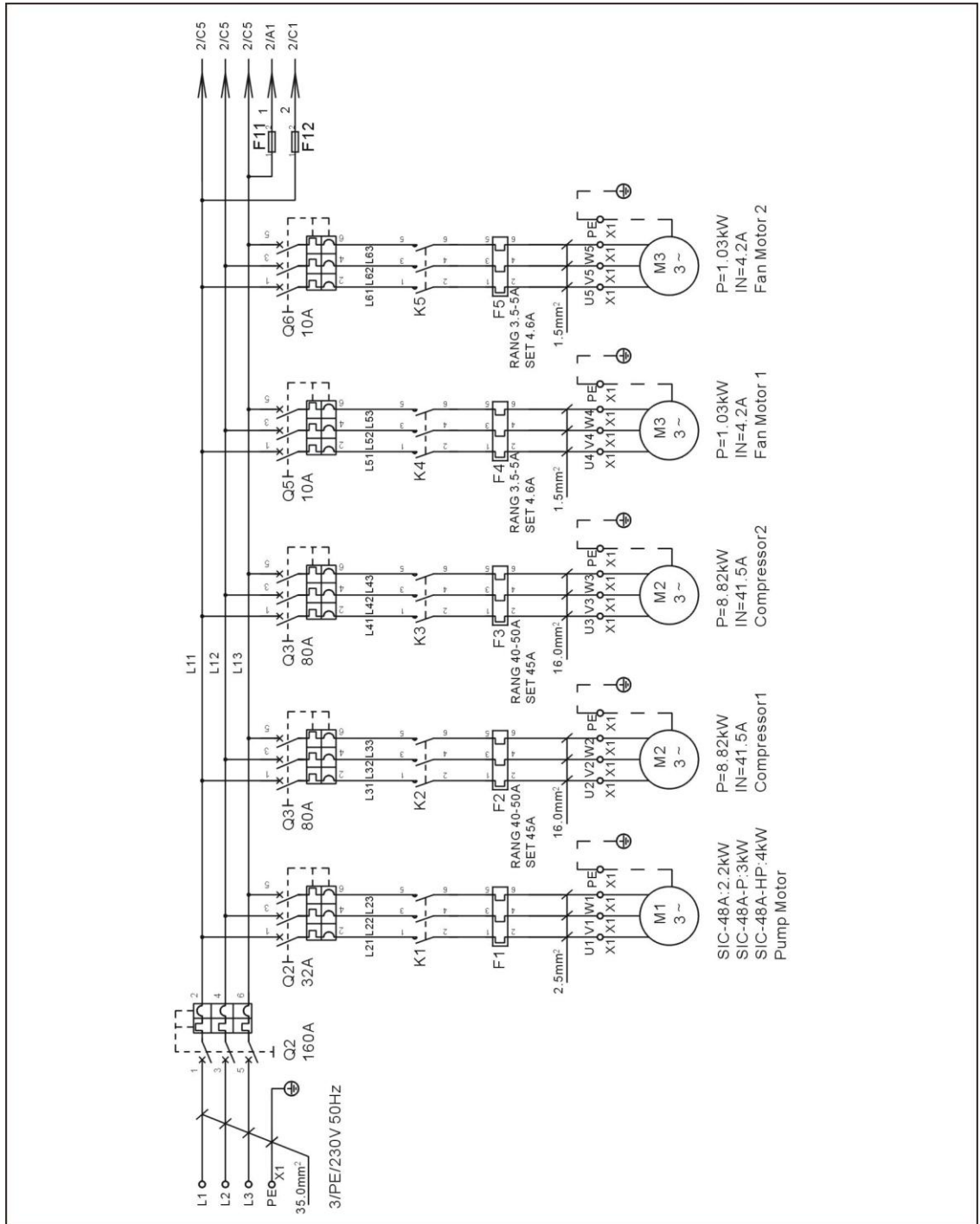

Picture 2-99: Main Electrical Circuit (SIC-58A-R2) (230V)

2.3.76 Control Circuit (SIC-58A-R2) (230V)

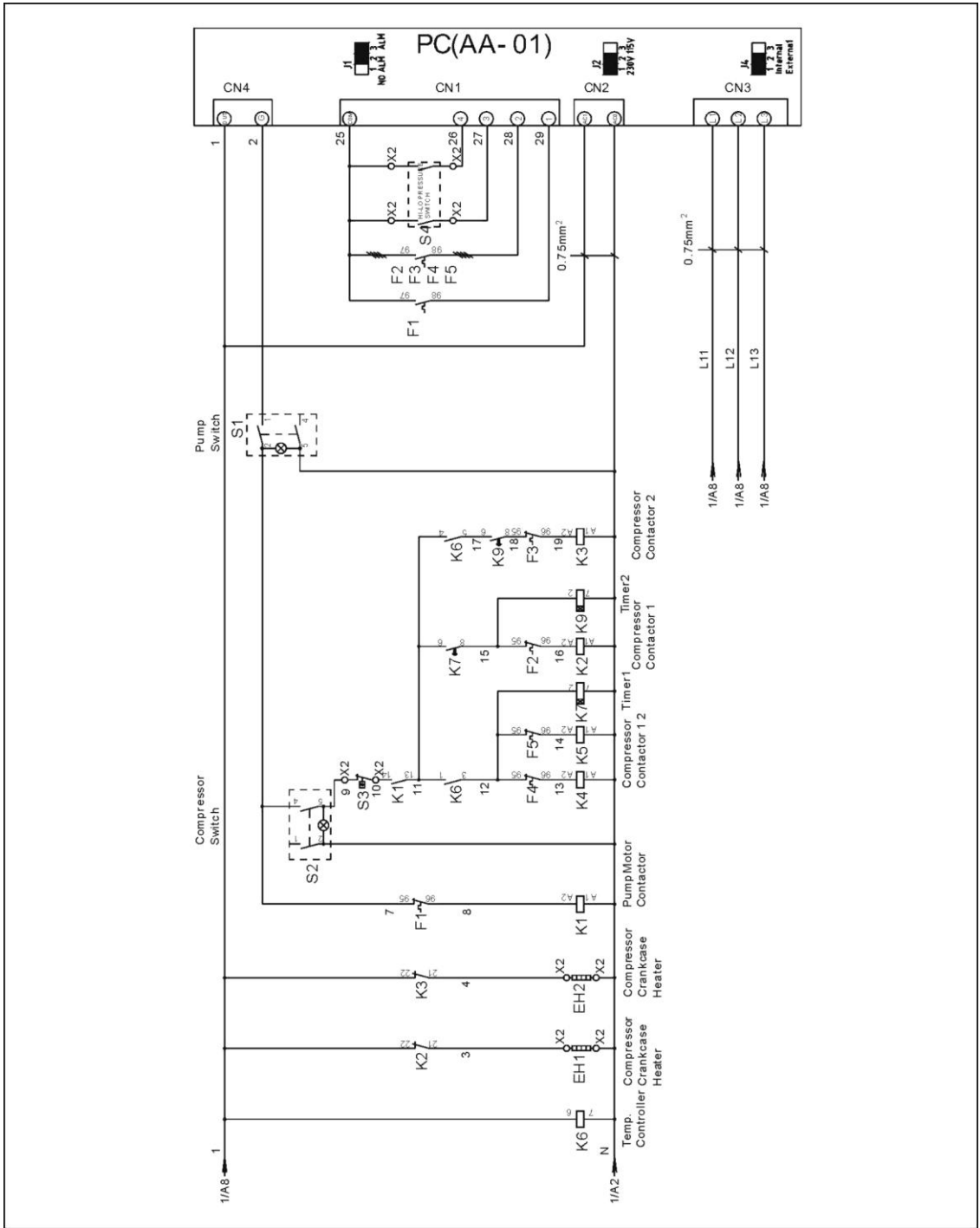

Picture 2-100: Control Circuit (SIC-58A-R2) (230V)

2.3.77 Electrical Components Layout (SIC-58A-R2) (230V)

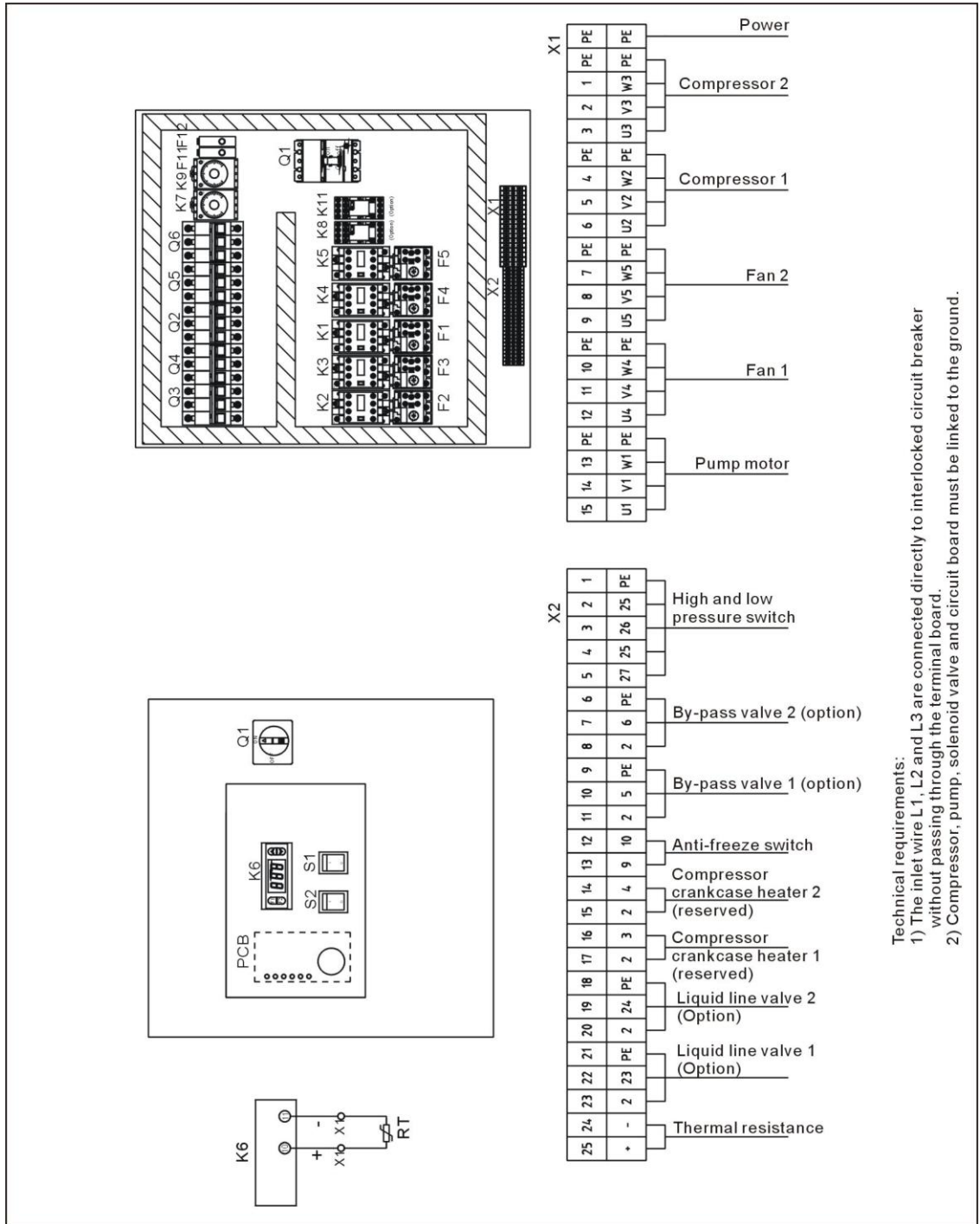

Technical requirements:
 1) The inlet wire L1, L2 and L3 are connected directly to interlocked circuit breaker without passing through the terminal board.
 2) Compressor, pump, solenoid valve and circuit board must be linked to the ground.

Picture 2-101: Electrical Components Layout (SIC-58A-R2) (230V)

2.3.78 Electrical Components List (SIC-58A-R2) (230V)

Table 2-51: Electrical Components List (SIC-58A-R2) (230V)

No.	Symbol	Name	Specificatons	Parts No.
1	Q1	Circuit breaker *	160A	YE41161600000
2	Q2	Circuit breaker *	32A	YE40603200000
3	Q3 Q4	Circuit breaker *	80A	YE40800300000
4	Q4 Q5	Circuit breaker *	10A	YE40600300000
5	K1	Contactoer *	220VAC 50/60Hz	-
6	K2 K3	Contactoer *	220VAC 50/60Hz	YE00503600000
7	-	Auxiliary block	1NC	YE00592110100
8	-	Auxiliary block	1NO	YE00592110000
9	-	Auxiliary block	1NO	YE00592110000
10	-	Auxiliary block	1NO	YE00592110000
11	K4 K5	Contactoer *	220VAC 50/60Hz	YE00601521000
12	K6	Temperature controller *	115~230VAC	YE85120200000
13	K7 K9	Timer	3S-60M AC220V	YE86300300000
14	K8 K11	Middle realy	AC220V	YE03270700000
15	F1	Overload relay *	-	-
16	F2 F3	Overload relay *	40~50A	YE01513600900
17	F4 F5	Overload relay *	3.5~5A	YE01160350000
18	F11	Fuse**	2A	YE41001000000
19	S1 S2	Control switch *	250V~10(5)A 4P WH	YE10210400000
20	S3	Anti-frozen switch *	-	-
21	S4	HI-LO pressure switch	-	-
22	PCB	Control board *	230V 50/60Hz	YE80000100000
23	X1	Terminal board	-	YE61353500000
24		Terminal board	-	YE61160000000
25		Terminal board	-	YE61163500000
26		Terminal board	-	YE61250040000
27		Terminal board	-	YE61253500000
28	X2	Terminal board	-	YE61250040000
29	-	Terminal board	-	YE61253500000
30	-	Terminal board	-	YE61250040000
31	-	Terminal board	-	YE61253500000
32	-	Terminal board	-	YE61250040000
33	-	Terminal board	-	YE61253500000
34	M1	Pump motor	230V 50/60Hz	-
35	M2 M3	Compressor	230V 50/60Hz 8.82kW	-
36	M4 M5	Fan motor	230V 50/60Hz 1.03kW	-
37	EH1	Compressor crankcase heater	230V 50/60Hz	-
38	Y1 Y2	Solenoid valve**	230V 50/60Hz	-
39	Y3 Y4	Solenoid valve**	230V 50/60Hz	-

* means possible broken parts. ** means easy broken parts. Spare backup is suggested.



Please confirm the version number of the manual before you order to ensure the stock number and the parts are consistent.

2.3.79 Main Electrical Circuit (SIC-75A-R2) (230V)

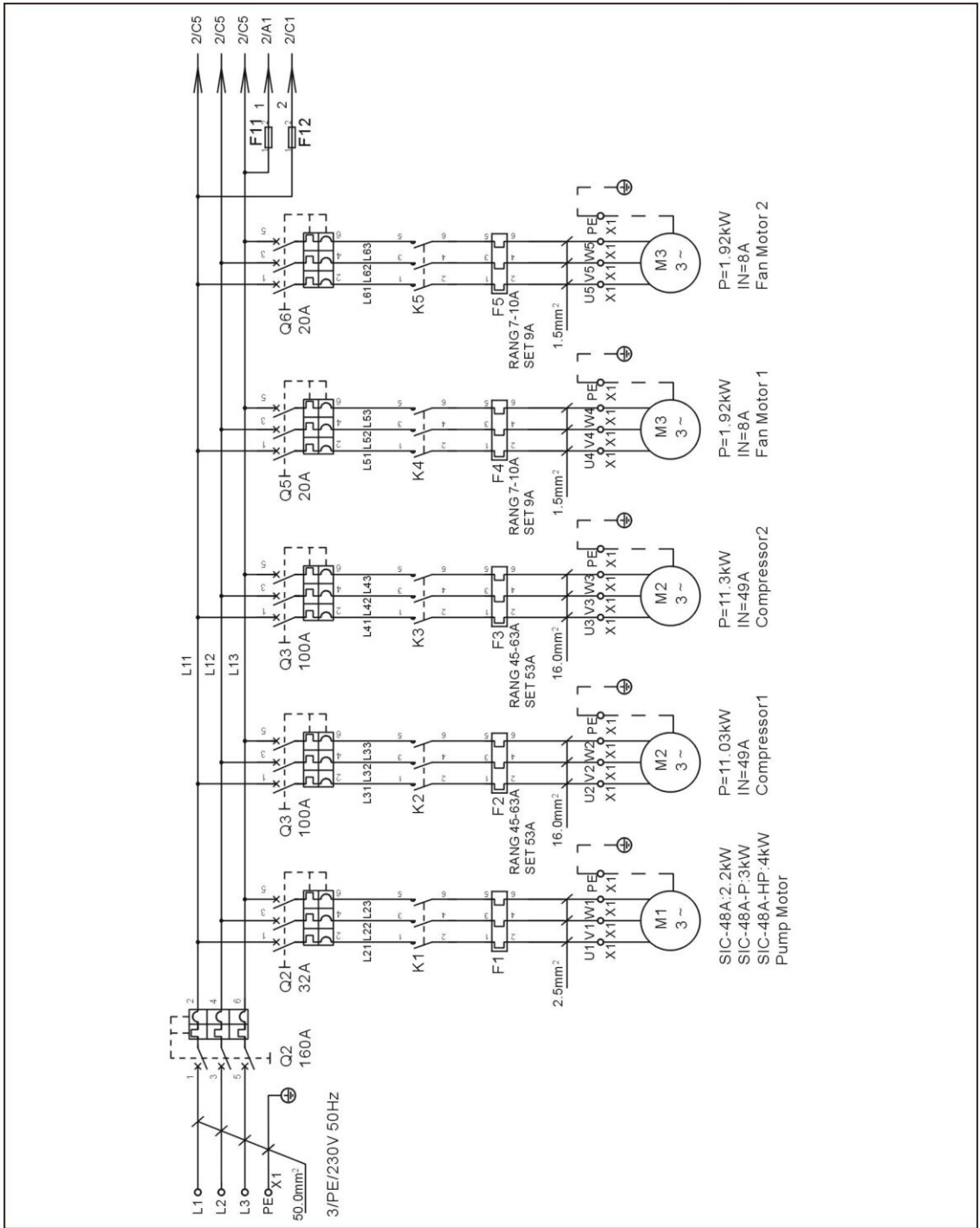

Picture 2-102: Main Electrical Circuit (SIC-75A-R2) (230V)

2.3.80 Control Circuit (SIC-75A-R2) (230V)

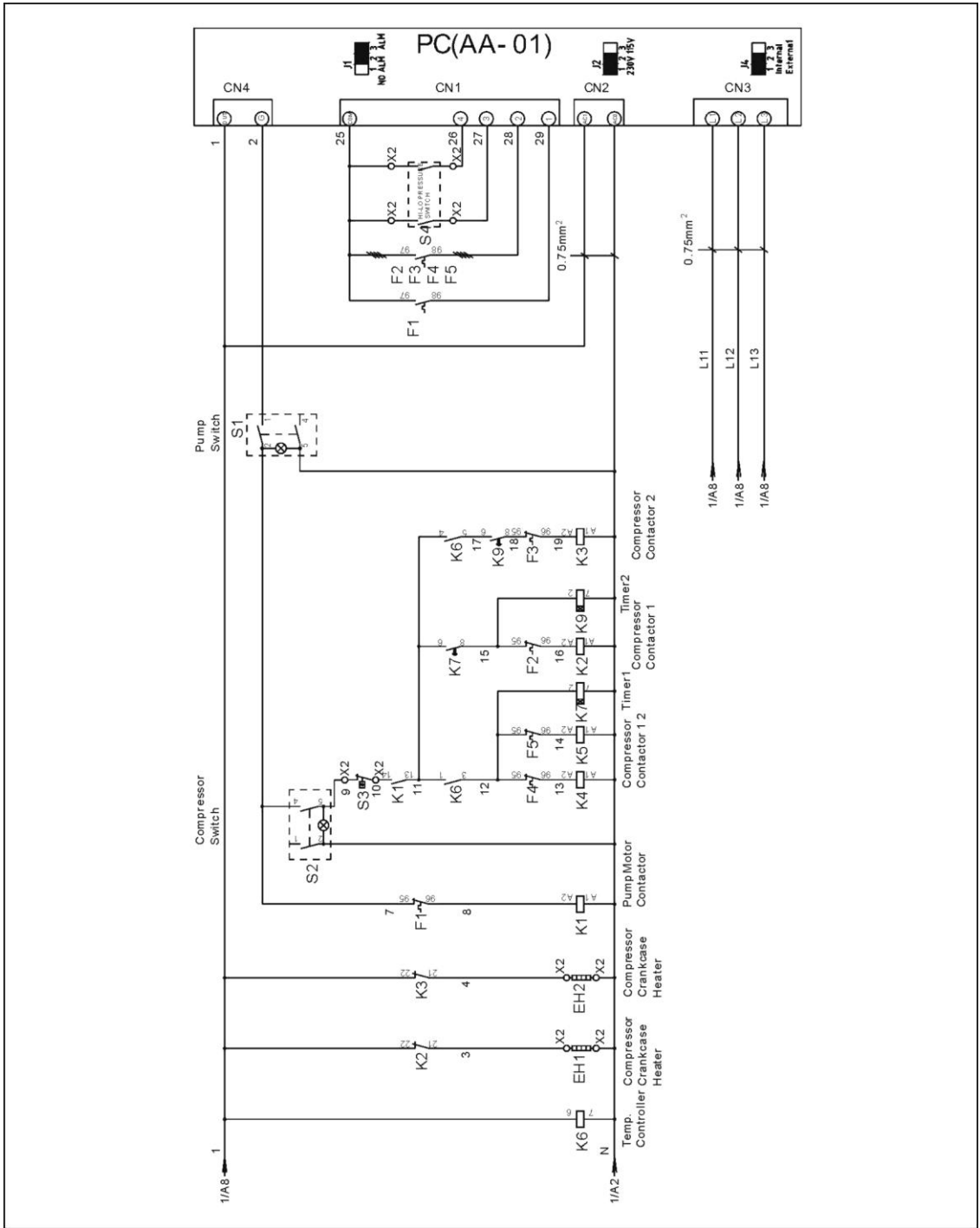

Picture 2-103: Control Circuit (SIC-75A-R2) (230V)

2.3.81 Electrical Components Layout (SIC-75A-R2) (230V)

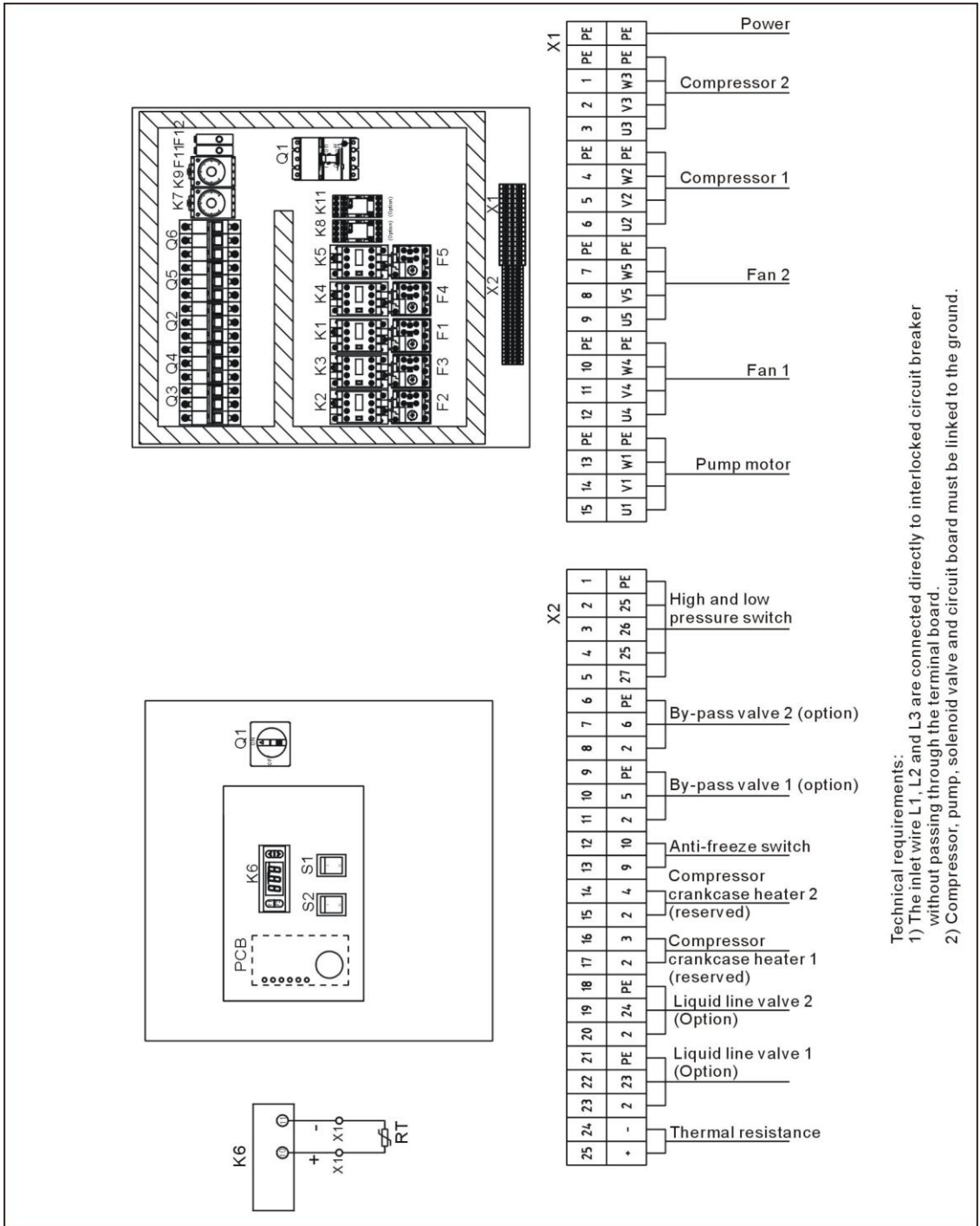

Technical requirements:
 1) The inlet wire L1, L2 and L3 are connected directly to interlocked circuit breaker without passing through the terminal board.
 2) Compressor, pump, solenoid valve and circuit board must be linked to the ground.

Picture 2-104: Electrical Components Layout (SIC-75A-R2) (230V)

2.3.82 Electrical Components List (SIC-75A-R2) (230V)

Table 2-52: Electrical Components List (SIC-75A-R2) (230V)

No.	Symbol	Name	Specifications	Parts No.
1	Q1	Circuit breaker *	160A	YE41161600000
2	Q2	Circuit breaker *	32A	YE40603200000
3	Q3 Q4	Circuit breaker *	100A	YE40100300000
4	Q4 Q5	Circuit breaker *	20A	YE40602000000
5	K1	Contactor *	220VAC 50/60Hz	-
6	K2 K3	Contactor *	220VAC 50/60Hz	YE00504400000
7	-	Auxiliary block	1NC	YE00592110100
8	-	Auxiliary block	1NO	YE00592110000
9	-	Auxiliary block	1NO	YE00592110000
10	-	Auxiliary block	1NO	YE00592110000
11	K4 K5	Contactor *	220VAC 50/60Hz	YE00601721000
12	K6	Temperature controller *	115~230VAC	YE85120200000
13	K7 K9	Timer	3S-60M AC220V	YE86300300000
14	K8 K11	Middle realy	AC220V	YE03270700000
15	F1	Overload relay *	-	-
16	F2 F3	Overload relay *	45~63A	YE01514640000
17	F4 F5	Overload relay *	7~10A	YE01167100000
18	F11	Fuse**	2A	YE41001000000
19	S1 S2	Control switch *	250V~10(5)A 4P WH	YE10210400000
20	S3	Anti-frozen switch *	-	-
21	S4	HI-LO pressure switch	-	-
22	PCB	Control board *	230V 50/60Hz	YE80000100000
23	X1	Terminal board	-	YE61353500000
24	-	Terminal board	-	YE61160000000
25	-	Terminal board	-	YE61163500000
26	-	Terminal board	-	YE61250040000
27	-	Terminal board	-	YE61253500000
28	X2	Terminal board	-	YE61250040000
29	-	Terminal board	-	YE61253500000
30	-	Terminal board	-	YE61250040000
31	-	Terminal board	-	YE61253500000
32	-	Terminal board	-	YE61250040000
33	-	Terminal board	-	YE61253500000
34	M1	Pump motor	230V 50/60Hz	-
35	M2 M3	Compressor	230V 50/60Hz 11.03kW	-
36	M4 M5	Fan motor	230V 50/60Hz 1.92kW	-
37	EH1	Compressor crankcase heater	230V 50/60Hz	-
38	Y1 Y2	Solenoid valve**	230V 50/60Hz	-
39	Y3 Y4	Solenoid valve**	230V 50/60Hz	-

* means possible broken parts. ** means easy broken parts. Spare backup is suggested. Please confirm the version number of the manual before you order to ensure the stock

number and the parts are consistent.

2.3.83 Main Electrical Circuit (SIC-100A-R2) (230V)

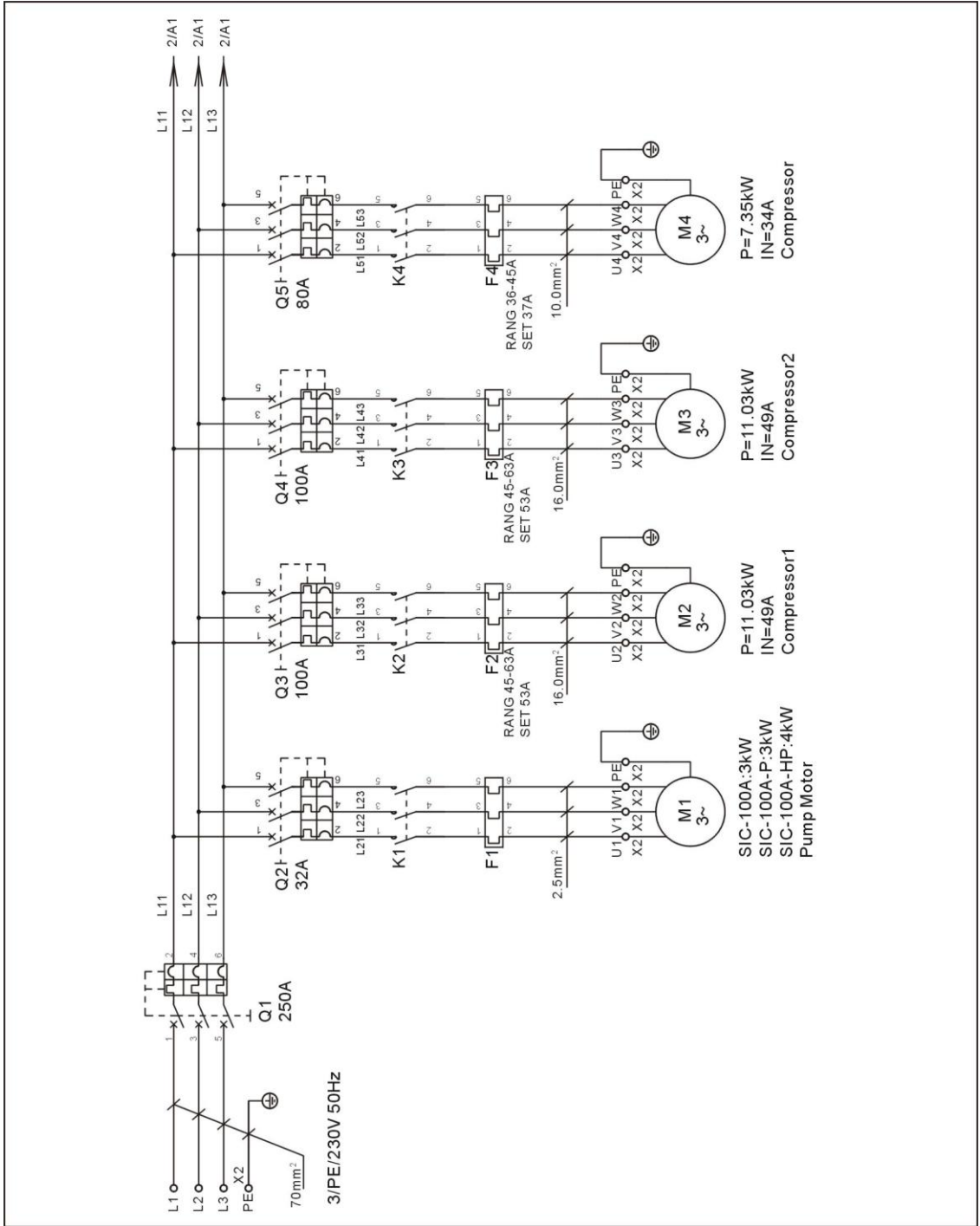

Picture 2-105: Main Electrical Circuit 1(SIC-100A-R2) (230V)

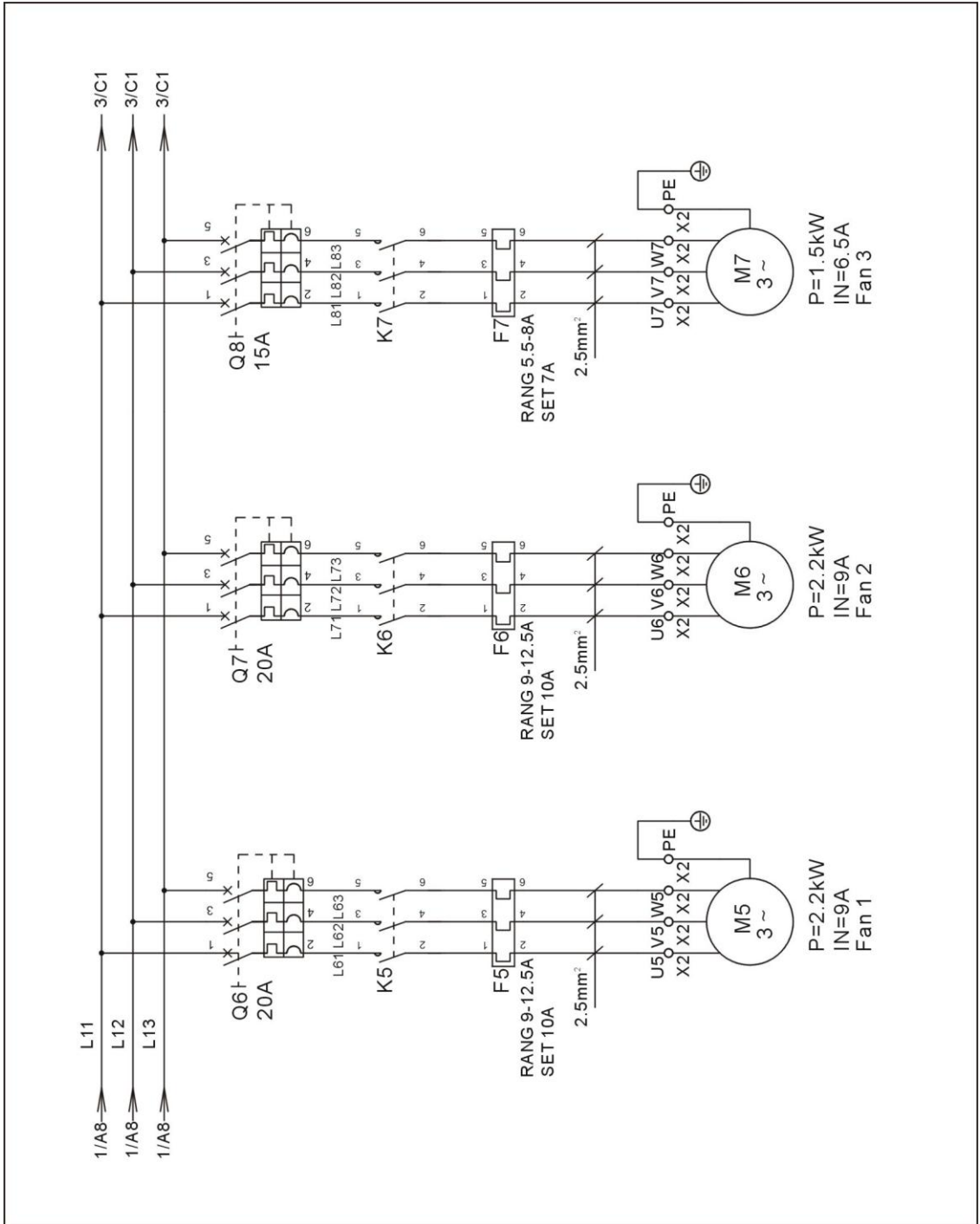

Picture 2-106: Main Electrical Circuit 2(SIC-100A-R2) (230V)

2.3.84 Control Circuit (SIC-100A-R2) (230V)

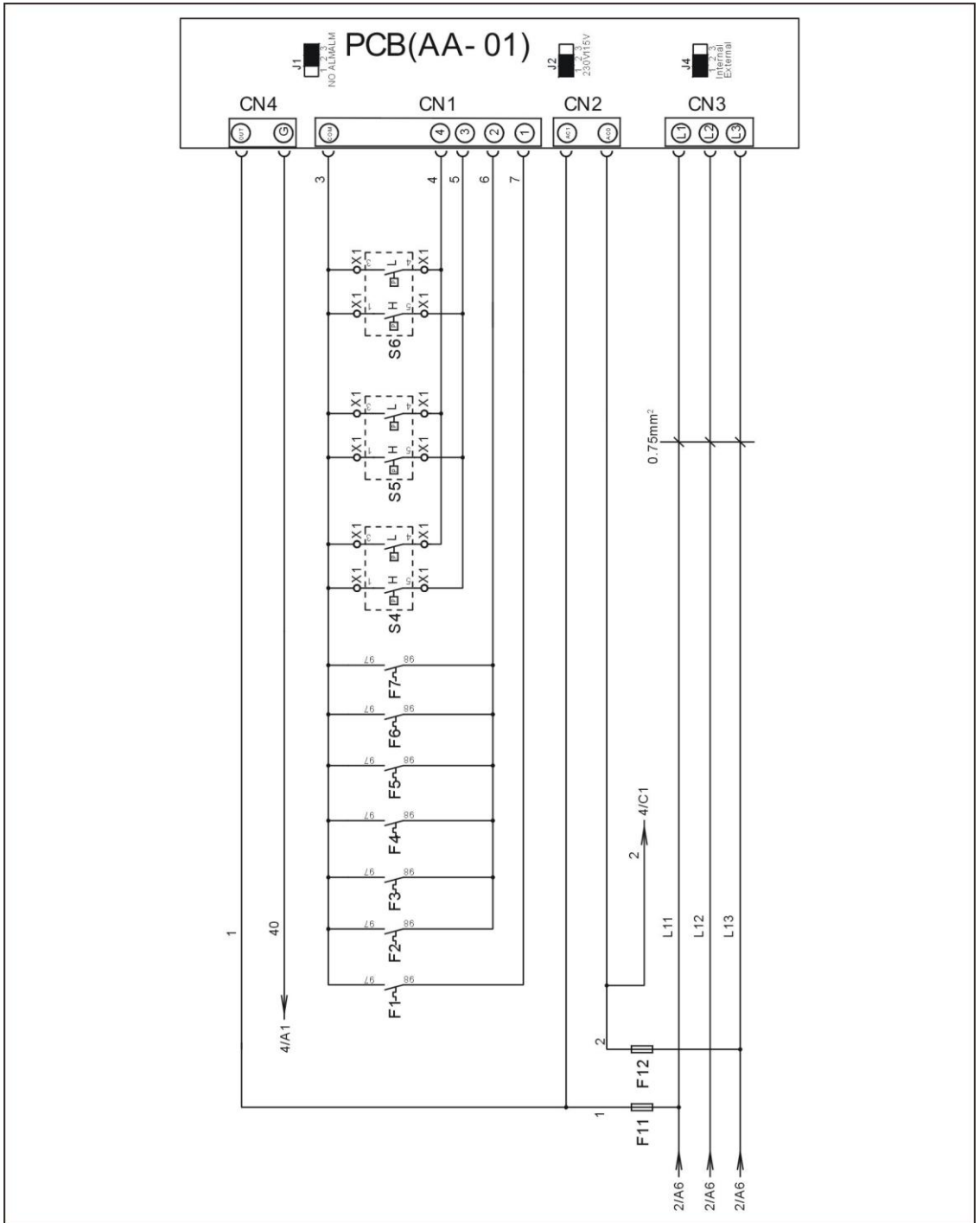

Picture 2-107: Control Circuit 1(SIC-100A-R2) (230V)

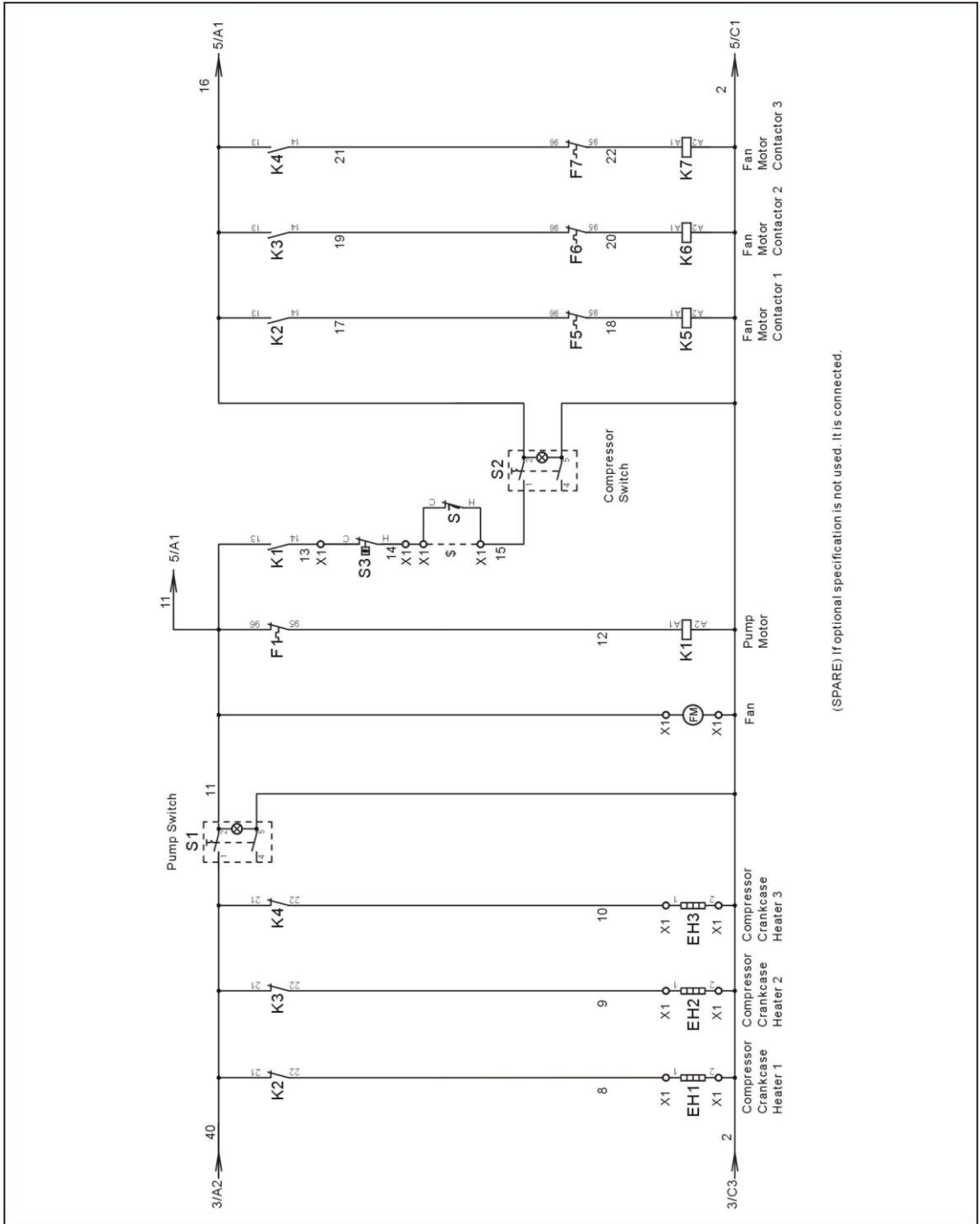

(SPARE) If optional specification is not used, it is connected.

Picture 2-108: Control Circuit 2(SIC-100A-R2) (230V)

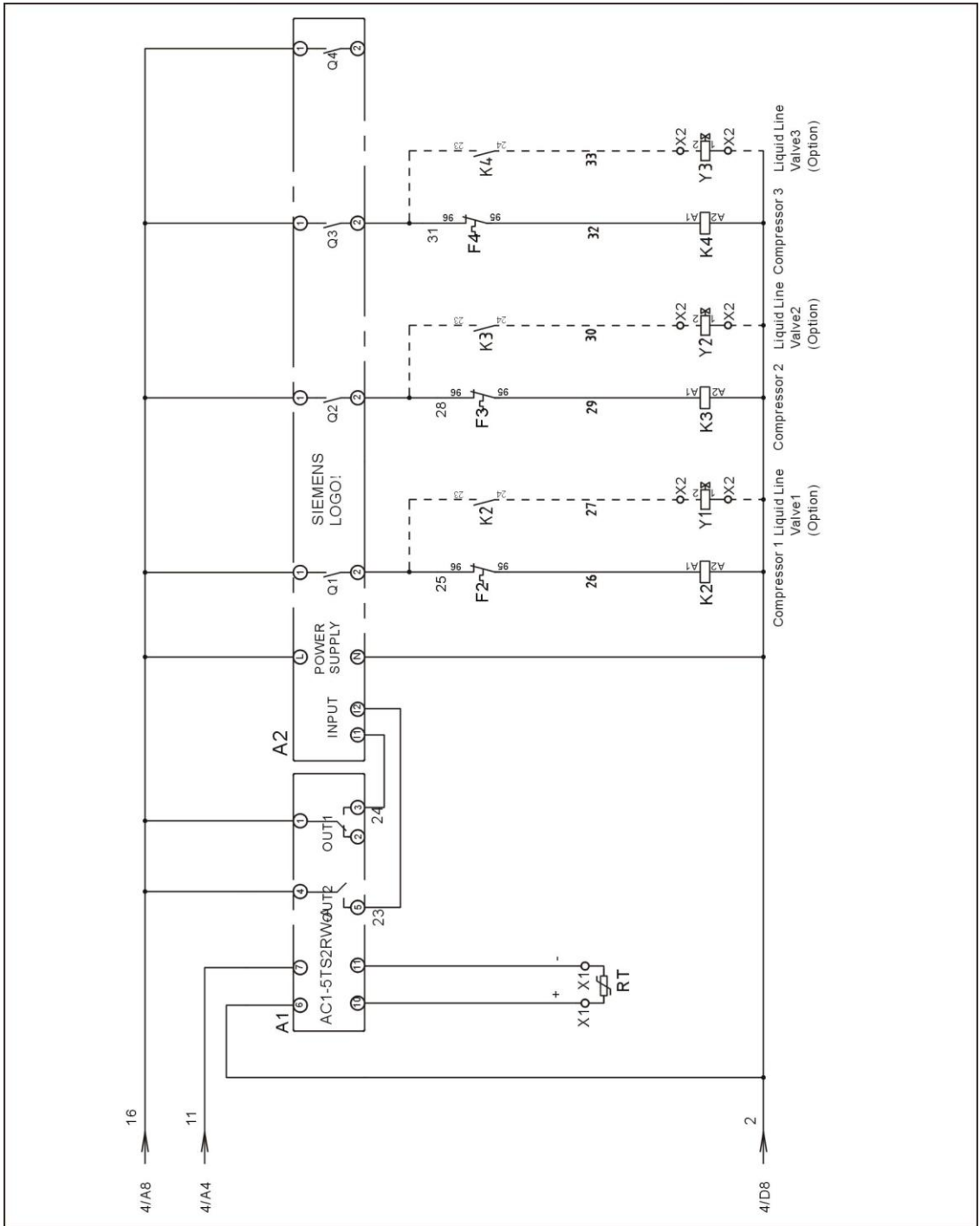

Picture 2-109: Control Circuit 3(SIC-100A-R2) (230V)

2.3.85 Electrical Components Layout (SIC-100A-R2) (230V)

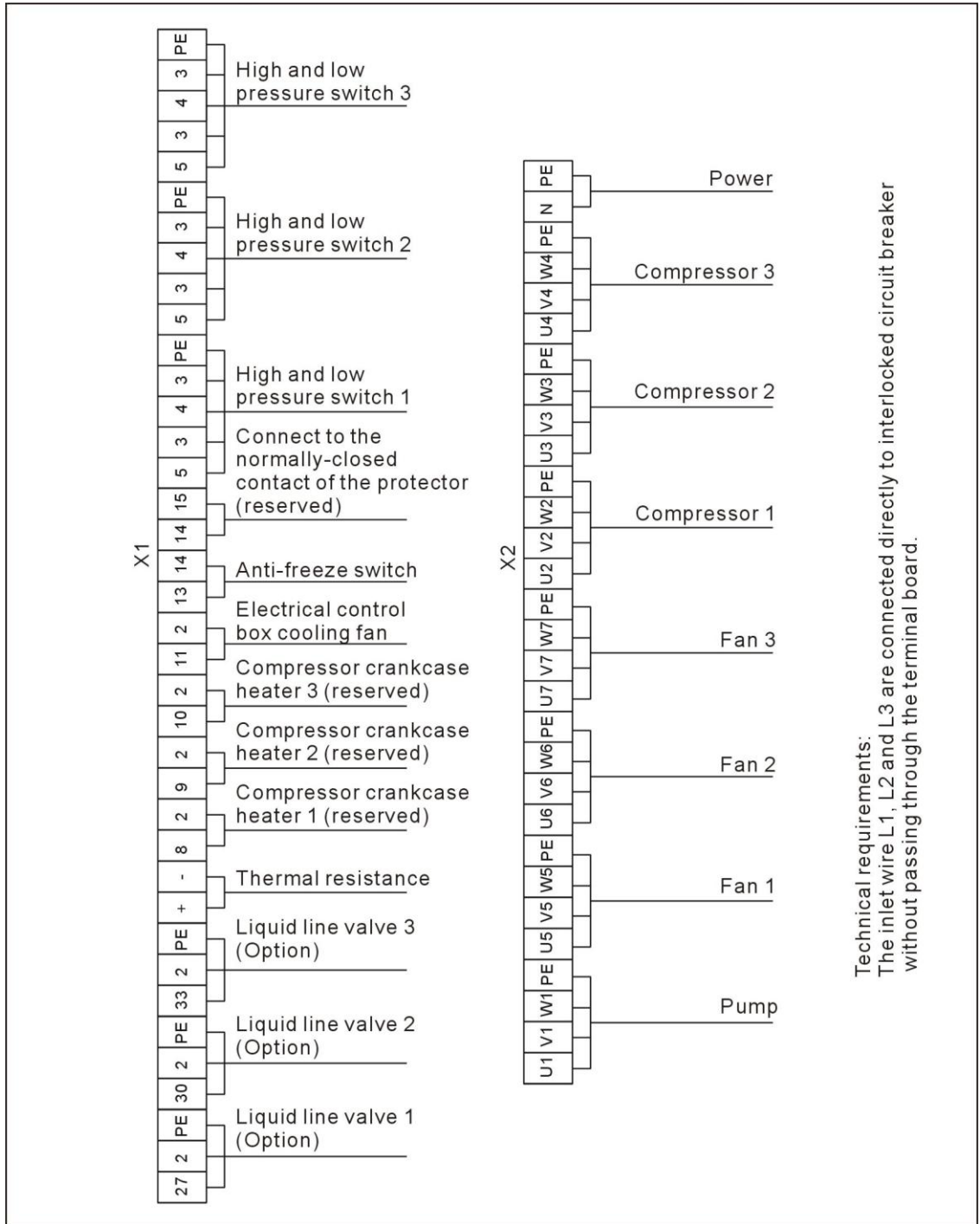

Picture 2-110: Electrical Components Layout 1(SIC-100A-R2) (230V)

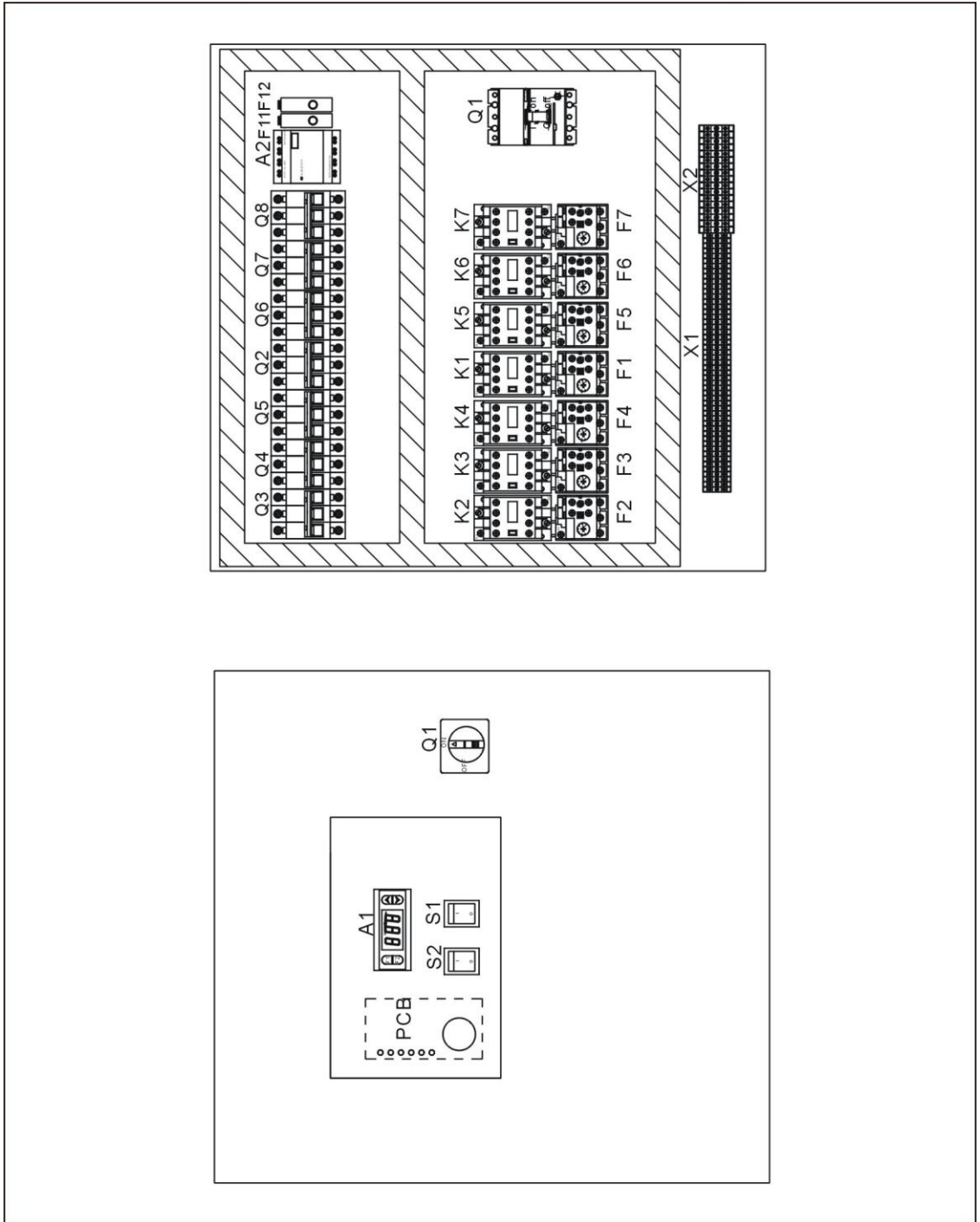

Picture 2-111: Electrical Components Layout 2(SIC-100A-R2) (230V)

2.3.86 Electrical Components List (SIC-100A-R2) (230V)

Table 2-53: Electrical Components List (SIC-100A-R2) (230V)

No.	Symbol	Name	Specificatons	Parts No.
1	Q1	Circuit breaker *	250A	YE41252500000
2	Q2	Circuit breaker *	32A	YE40603200000
3	Q3 Q4	Circuit breaker *	100A	YE40100300000
4	Q5	Circuit breaker *	80A	YE40800300000
5	Q6 Q7	Circuit breaker *	20A	YE40602000000
6	Q8	Circuit breaker *	20A	YE40602000000
7	K1	Contactora *	220VAC 50/60Hz	-
8	K2 K3	Contactora *	220VAC 50/60Hz	YE00504400000
9	K4	Contactora *	220VAC 50/60Hz	YE00503500000
10	-	Auxiliary block	1NC	YE00592110100
11	-	Auxiliary block	1NO	YE00592110000
12	-	Auxiliary block	1NO	YE00592110000
13	K5 K6	Contactora *	220VAC 50/60Hz	YE00601721000
14	K7	Contactora *	220VAC 50/60Hz	YE00601621000
15	A1	Temperature controller *	115~230VAC	YE85120200000
16	A2	LOGO! Controller	AC115~230V	YE81023000000
17	RT	Temperature sensor	-	-
18	F1	Overload relay *	-	-
19	F2 F3	Overload relay *	45~63A	YE01514640000
20	F4	Overload relay *	36~45A	YE01612660000
21	F5 F6	Overload relay *	9~12.5A	YE01169125000
22	F7	Overload relay *	5.5~8A	YE01160550000
23	F11 F12	Fuse**	2A	YE41001000000
24	S1 S2	Control switch *	250V~10(5)A 4P WH	YE10210400000
25	S3	Anti-frozen switch *	-	-
26	S4~S6	HI-LO pressure switch	H:5~30bar L:-0.7~6bar	-
27	PCB	Control board *	230V 50/60Hz	YE80000100000
28	X1	Terminal board	-	YE61250040000
29	-	Terminal board	-	YE61253500000
30	-	Terminal board	-	YE61250040000
31	-	Terminal board	-	YE61253500000
32	X2	Terminal board	-	YE61353500000
33	-	Terminal board	-	YE61160000000

34	-	Terminal board	-	YE61163500000
No.	Symbol	Name	Specificatons	Parts No.
35	-	Terminal board	-	YE61100000000
36	-	Terminal board	-	YE61103500000
37	-	Terminal board	-	YE61250040000
38	-	Terminal board	-	YE61253500000
39	M1	Pump motor	230V 50/60Hz	-
40	M2 M3	Compressor	230V 50/60Hz 11.03kW	-
41	M4	Compressor	230V 50/60Hz 7.35kW	-
42	M5	Fan motor	230V 50/60Hz 2.2kW	-
43	M6 M7	Fan motor	230V 50/60Hz 1.5kW	-
44	EH1~EH3	Compressor crankcase heater	230V 50/60Hz 45W	-
45	Y1~Y3	Solenoid valve**	230V 50/60Hz	-

* means possible broken parts. ** means easy broken parts. Spare backup is suggested. Please confirm the version number of the manual before you order to ensure the stock number and the parts are consistent.

2.3.87 Main Electrical Circuit (SIC-114A-R2) (230V)

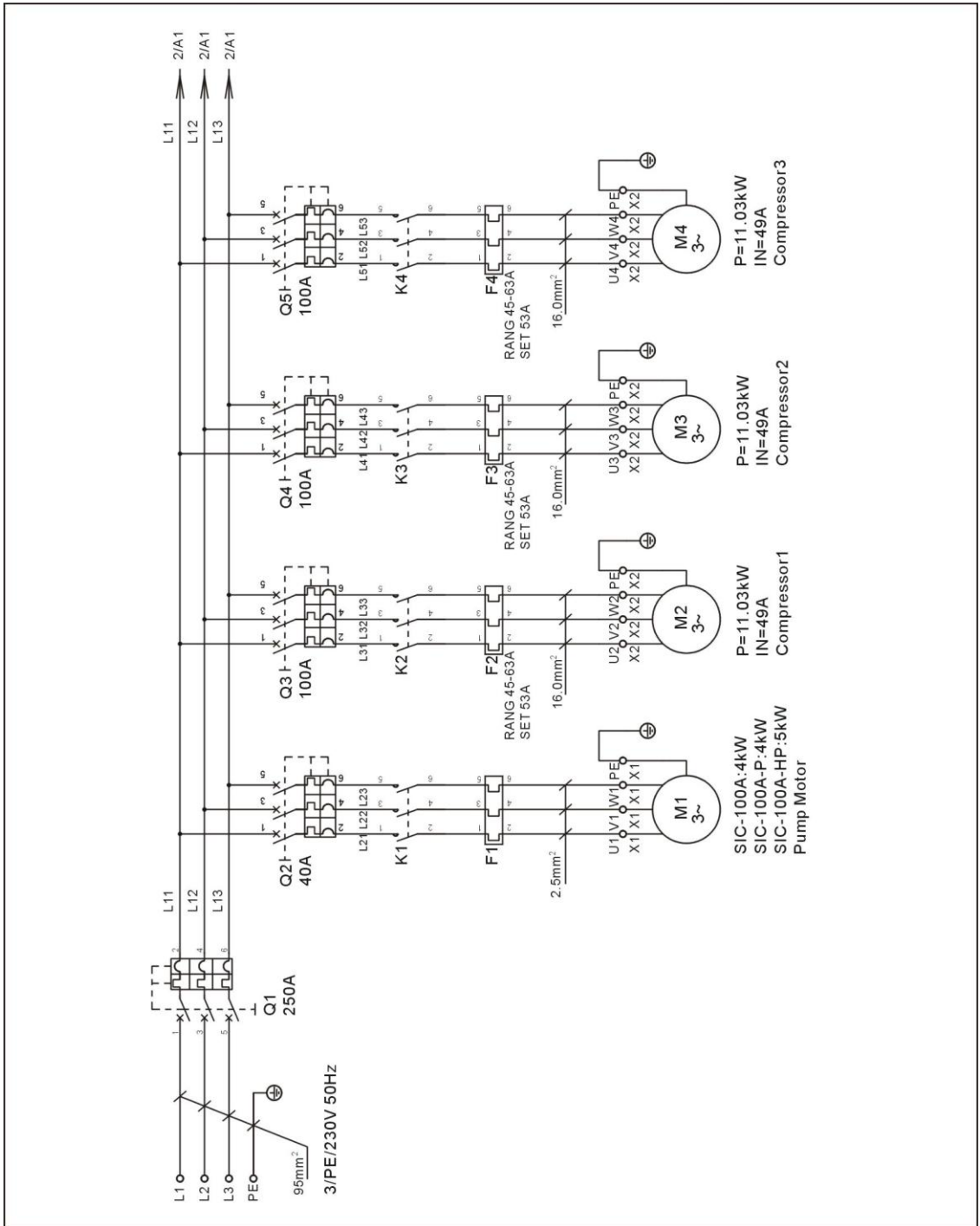

Picture 2-112: Main Electrical Circuit 1(SIC-114A-R2) (230V)

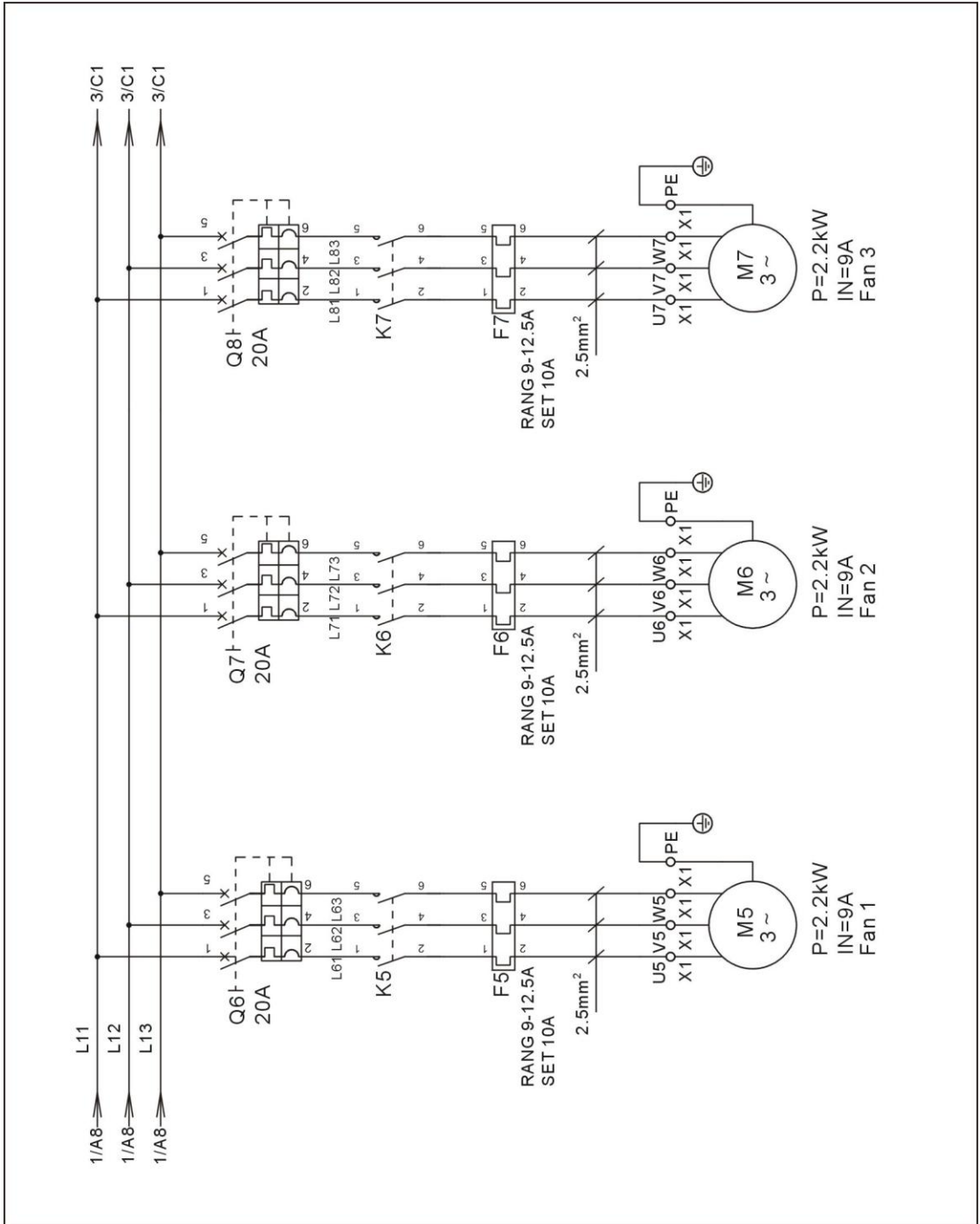

Picture 2-113: Main Electrical Circuit 2(SIC-114A-R2) (230V)

2.3.88 Control Circuit (SIC-114A-R2) (230V)

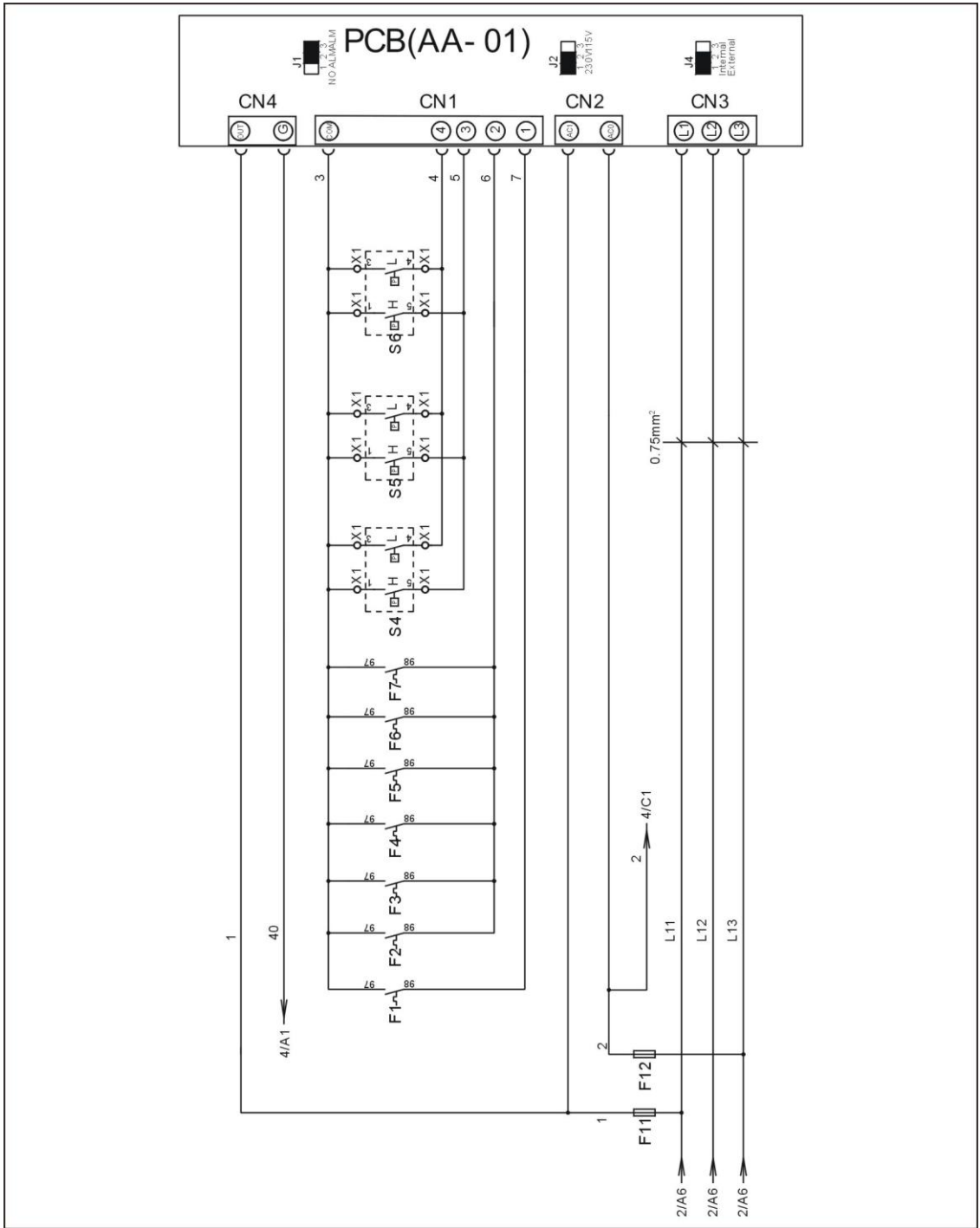

Picture 2-114: Control Circuit 1(SIC-114A-R2) (230V)

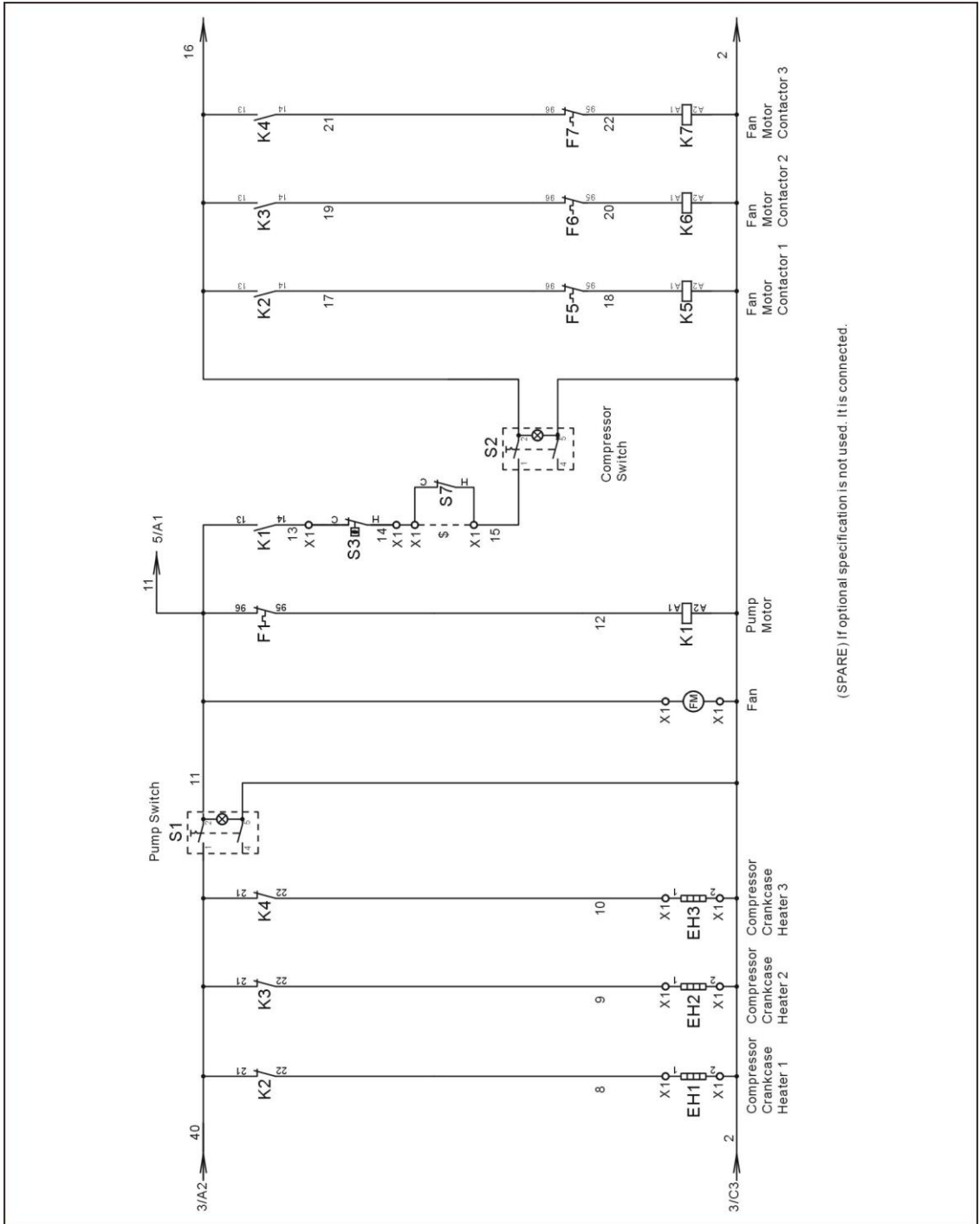

Picture 2-115: Control Circuit 2(SIC-114A-R2) (230V)

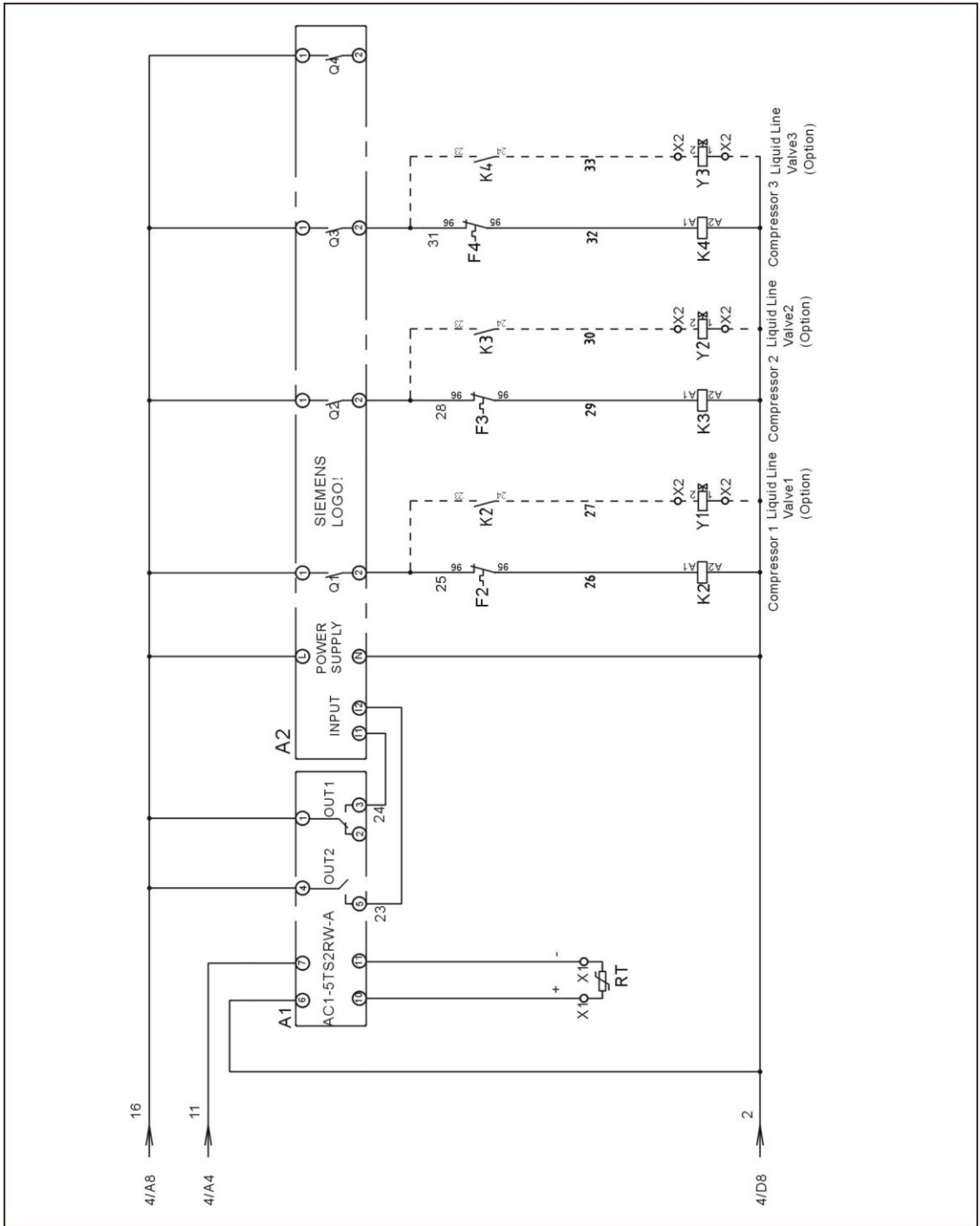

Picture 2-116: Control Circuit 3(SIC-114A-R2) (230V)

2.3.89 Electrical Components Layout (SIC-114A-R2) (230V)

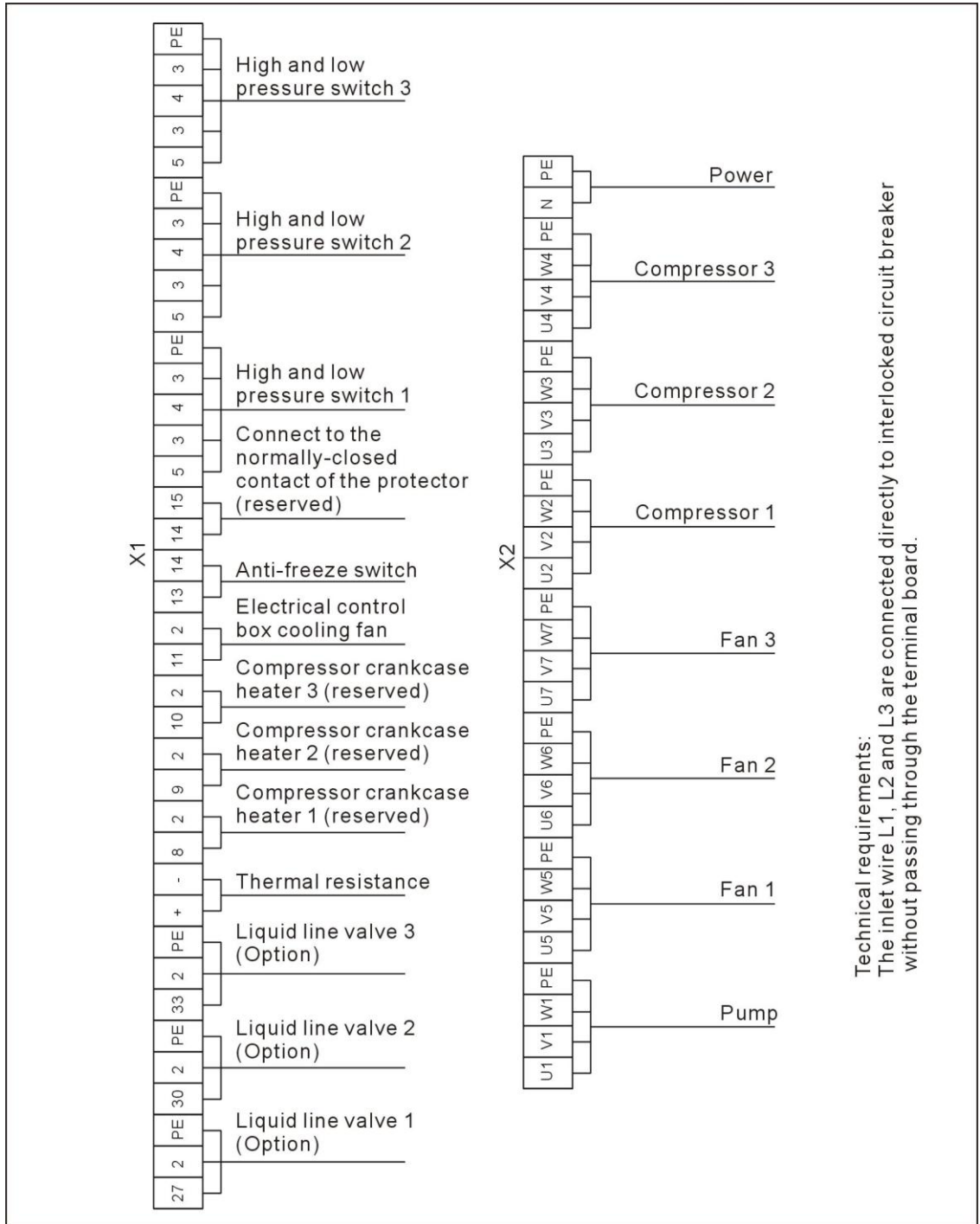

Picture 2-117: Electrical Components Layout 1(SIC-114A-R2) (230V)

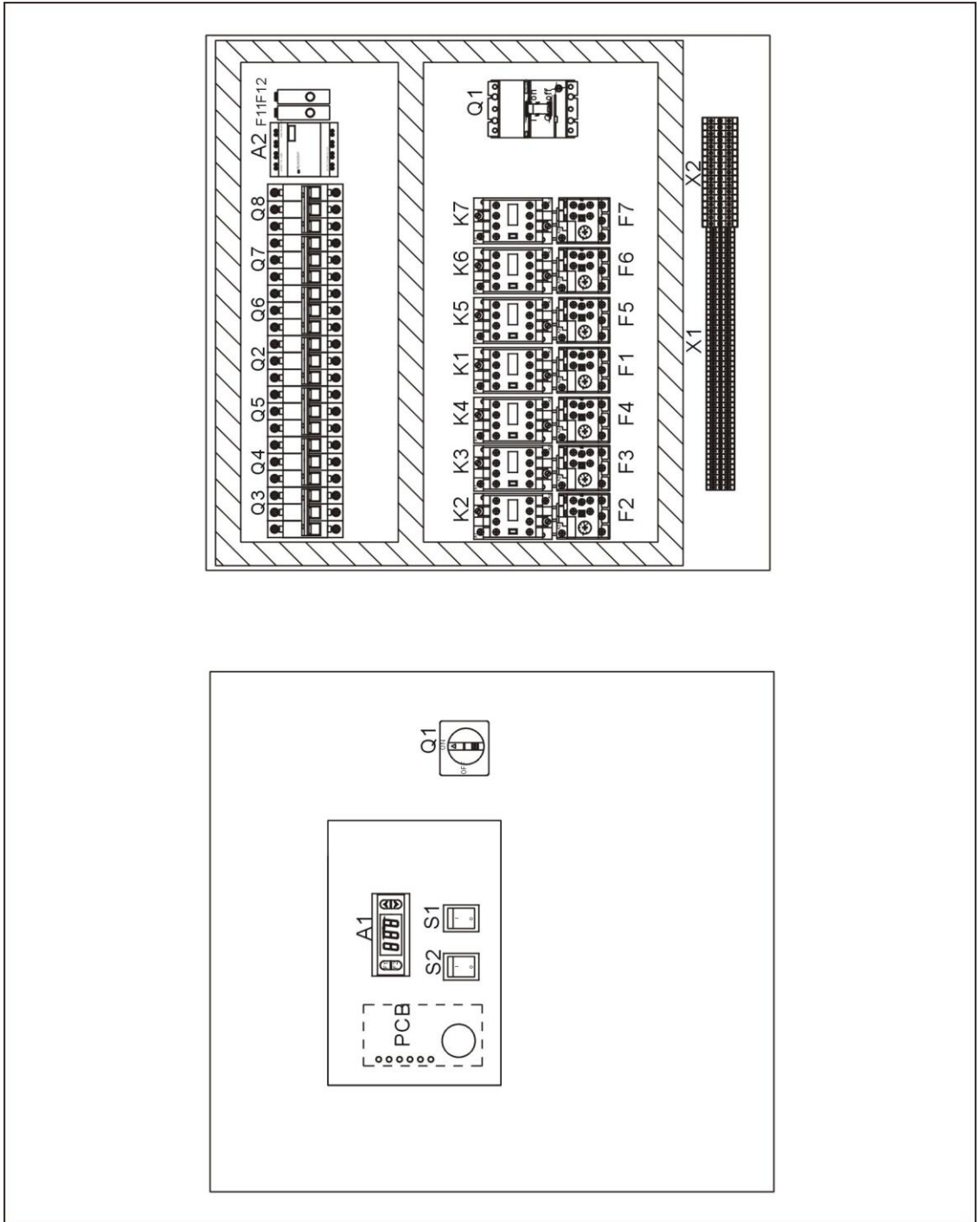

Picture 2-118: Electrical Components Layout 2(SIC-114A-R2) (230V)

2.3.90 Electrical Components List (SIC-114A-R2) (230V)

Table 2-54: Electrical Components List (SIC-114A-R2) (230V)

No.	Symbol	Name	Specificatons	Parts No.
1	Q1	Circuit breaker *	250A	YE41252500000
2	Q2	Circuit breaker *	40A	YE40604000000
3	Q3~Q5	Circuit breaker *	100A	YE40100300000
4	Q6~Q8	Circuit breaker *	20A	YE40602000000
5	K1	Contactor *	220VAC 50/60Hz	-
6	K2~K4	Contactor *	220VAC 50/60Hz	YE00504400000
7	-	Auxiliary block	1NC	YE00592110100
8	-	Auxiliary block	1NO	YE00592110000
9	-	Auxiliary block	1NO	YE00592110000
10	K5~K7	Contactor *	220VAC 50/60Hz	YE00601721000
11	A1	Temperature controller *	115~230VAC	YE85120200000
12	A2	LOGO! Controller	AC115~230V	YE81023000000
13	RT	Temperature sensor	-	-
14	F1	Overload relay *	-	-
15	F2~F4	Overload relay *	45~63A	YE01514640000
16	F5~F7	Overload relay *	9~12.5A	YE01169125000
17	F11 F12	Fuse**	2A	YE41001000000
18	S1 S2	Control switch *	250V~10(5)A 4P WH	YE10210400000
19	S3	Anti-frozen switch *	-	-
20	S4~S6	HI-LO pressure switch	H:5~30bar L:-0.7~6bar	-
21	PCB	Control board *	230V 50/60Hz	YE80000100000
22	X1	Terminal board	-	YE61250040000
23	-	Terminal board	-	YE61253500000
24	-	Terminal board	-	YE61250040000
25	-	Terminal board	-	YE61253500000
26	X2	Terminal board	-	YE61353500000
27	-	Terminal board	-	YE61160000000
28	-	Terminal board	-	YE61163500000
29	-	Terminal board	-	YE61250040000
30	-	Terminal board	-	YE61253500000
31	M1	Pump motor	230V 50/60Hz	-
32	M2~M4	Compressor	230V 50/60Hz 11.03kW	-
33	M5~M7	Fan motor	230V 50/60Hz 2.2kW	-
34	EH1~EH3	Compressor crankcase heater	230V 50/60Hz 45W	-
35	Y1~Y3	Solenoid valve**	230V 50/60Hz	-

* means possible broken parts. ** means easy broken parts. Spare backup is suggested. Please confirm the version number of the manual before you order to ensure the stock number and the parts are consistent.

2.4 Main Electrical Components

2.4.1 Thermal Overload Relay

At delivery, the overload relay is set for manual reset (the reset button pointing to H). Manually reset the relay at the tripping off of the switch. When motor overload occurs, stop the machine. Check and solve the problem first. Then open the door of control box, press down the reset button of overload relay. (If you can not press down the reset button, wait for one more minute)

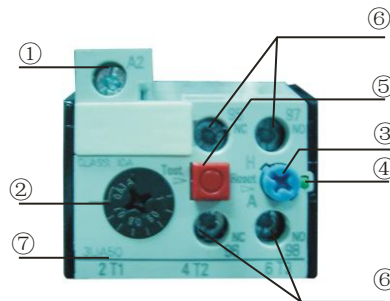

Picture 2-119: Thermal Overload Relay

Description of Thermal Overload Relay:

- 1) Terminal for contact coil A2.
- 2) Setting current adjusting scale.
- 3) Reset (blue).
- H: manual reset
- A: automatic reset
- 4) Switch position indication (green).
- 5) Test button (red).
- 6) Auxiliary contact terminals shown in 95,96,97,98.

NC and NO contacts are shown in position 95, 96 and 97, 98 respectively.

Tripping off of a manual-resetting is indicated by a pin projecting at the front plate.

- 7) Main circuit connection No. must correspond with terminal number of contactor.

3. Installation and Debugging



Attention!

Read this chapter before installation. Install the machine according to following steps!

Air-cooled water chiller should be installed in an environment that has good ventilation, such as draughty area near the window. Ambient temperature should not be more than 43°C if it is installed indoors. Use ventilator or exhaust pipe to conduct the hot air produced by the chiller to the outside. If the chiller is installed outdoors, protective cover should be used.

3.1 Installation Notices

- 1) Make sure that the voltage and frequency corresponds with the requirements on manufacturer's name plate.
- 2) Connection of the machine electrical wires and negative wire according to local rules and regulations.
- 3) Use independent electrical wires and switch. Diameter of electrical wire should not be smaller than that of the electric wire which is used for the electrical control box.
- 4) Wiring connections should be firmly fixed.
- 5) The chiller use three phase & five core wire. Connect wire N to null wire, G to earth wire, and others to live wire.
- 6) Power supply:
Voltage deviation: Rated voltage on the nameplate: $\pm 5\%$
Frequency deviation: $\pm 2\%$
- 7) According to the installation configuration diagram to install the pipe system, and use thermal insulation materials to protect the refrigerated water pipe.
- 8) At the lowest part of cooling water circulation, drainage valve should be installed.
- 9) Water filter should used in the cooling water and chilled water circulation pipe if water quality and surroundings of cooling tower is bad.
- 10) After the installation is completed, check if there are leakages in the circulation system. Cooling water circulation pipe should be covered with a

layer of insulated material to avoid temperature increasing and water drops forming on the surface of circulation pipe.



Electrical wire connection of water chiller should be done by qualified electrician! Electrical wiring circuit should not be modified unless authorized by our company. We shall not be reliable for machine damages caused by unauthorized modification.

3.2 Schematic Drawing of Installation

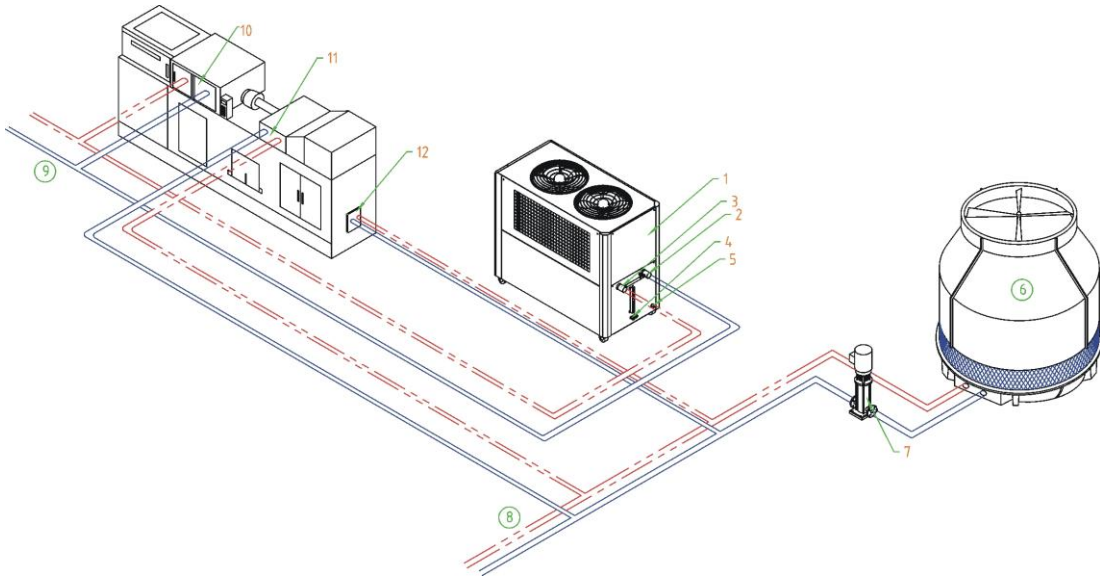

Parts Name :

- | | | | |
|------------------------------|------------------------|------------------------------|------------------|
| 1. Water chiller | 2. Chilled water inlet | 3. Chilled water outlet | 4. Water outfall |
| 5. Water refill port | 6. Chilled water tower | 7. Cooling water pump | |
| 8. Cooling water circulation | | 9. Chilled water circulation | |
| 10. Mould Cooling | 11. Cooling tank | 12. Oil Cooling | |

Picture 3-1: Installation Location

3.3 Power Supply

SIC-A-R2 series should be connected with 3φ 400V 50Hz power and earth wire and null wire.



Attention!

Before connecting the machine with power supply, please make sure that main switch is turned off!

4. Application and Operation

4.1 Control Panel

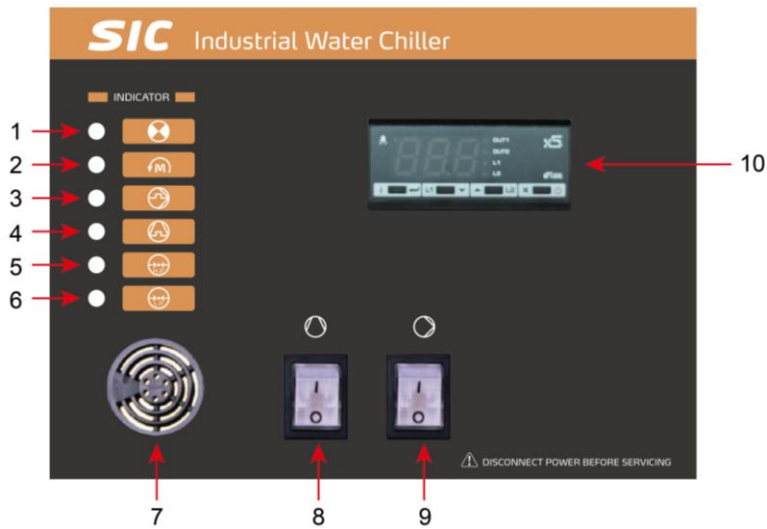

Picture 4-1: Control Panel

Table 4-1: Specification of Control Panel

No.	Name	Functions	Remarks
1	Power indicator	Connect through power supply and turn on the main switch, the indicator will become bright.	Note: Do not disassemble any electrical components or terminals in case of electrical shock.
2	Anti-phase indicator	It is used to indicate phase reversal or phase shortage. The buzzer sounds and system stops working.	Check the power supply and exchange two of the live wires to reset the alarm.

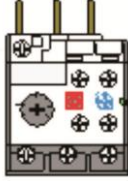
No.	Name	Functions	Remarks
3	Pump overload indicator	When pump current exceeds the limits, this indicator becomes bright. The buzzer sounds and system stops working.	<p>Check if the motor is blocked or the bearing is broken. If motor works normally, please check if the setting current of the overload relay in the control box is set too low. After the above measures are taken, wait for about 1 minute, then press the blue "reset" button to reset the alarm.</p> 
4	Compressor overload alarm light	If working current of the compressor is above the setting current of overheat relay, the alarm will be raised. The buzzer sounds and system stops working.	Check if the setting current of overheat relay is correct. Setting current of overheat relay should be bigger than the rated current of the compressor.
5	Over-pressure alarm light	When the outlet pressure of the compressor is higher than setting value of high-pressure switch, the alarm will be raised. The buzzer sounds and system stops working.	High-pressure switch setting value should be correctly set as 37 bar.
6	Under-pressure alarm light	When the inlet pressure of compressor is lower than setting value of low-pressure switch, the alarm will be raised. The buzzer sounds and system stops working.	Low-pressure switch should be correctly set as 4 bar. .
7	Buzzer	The buzzer makes audible alarm when problems are detected.	
8	Compressor switch	The start & stop of the compressor.	Note: Before turning on the compressor, turn on the pump first.
9	Pump switch	The start & stop of the pump.	Note: Pump rotating direction should be correct.
10	Temperature controller	Temperature setting and controlling.	Detail information please refer to Chapter 4-4.

4.2 Machine startup

- 1) Turn on the main switch.



Picture 4-2: Stepup Step 1

- 2) Turn on the pump.

Model \ Type	50Hz		60Hz	
	Medium pressure	High pressure	Medium pressure	High pressure
SIC-7.5A-R2	1.5~3.6	2.1~4.4	1.9~3.6	2.4~5.1
SIC-12A-R2	1.5~3.5	2.1~4.3	1.9~3.1	2.4~5.0
SIC-18A-R2	2.1~3.9	2.6~4.7	1.8~3.3	2.4~4.6
SIC-24A-R2	2.1~3.4	2.6~4.2	1.8~3.0	2.4~4.1
SIC-28A-R2	2.3~3.8	2.8~4.8	2.6~4.0	2.6~4.0
SIC-38A-R2	2.3~3.7	2.8~4.5	2.6~3.9	2.6~3.9
SIC-48A-R2	2.3~3.8	3.7~4.4	3.3~4.3	4.0~5.4
SIC-58A-R2	2.3~3.7	3.7~4.3	3.3~3.5	4.0~4.2
SIC-75A-R2	2.3~3.6	3.7~4.2	2.6~4.4	2.6~4.4
SIC-100A-R2	2.3~3.1	3.7~3.9	2.6~3.8	2.6~3.8
SIC-114A-R2	1.9~3.7	4.2~5.0	3.1~4.1	3.1~4.1
Units: bar 1bar=0.1Mpa				

Noets: 1) When the operation pressure is lower than the values in the table above, the motor of the pump may be damaged because of large water flow.

2) When the operation pressure is higher than the vaues in the table above, the water flow may be insufficient and the machine may need a pump replacement to ensure high pressure.

- 3) Turn on the compressor.

- 4) Set process water temperature (Neglect this step if temperature is already

set). Press ▲ ▼ to increase or decrease water temperature. For this series of water chiller, process water temperature should be set as 7°C (never set below 5°C).

5) Anti-freezing setting: anti-freezing switch equipped (setting value 5°C). When process water temperature is lower than 5°C, the compressor will stop working.



Attention!

Pump rotating direction should be correct.



Attention!

Before starting the system, make sure that cooling water pump is turned on. Check the water tank of the chiller. Do not start the machine when there is no water left in water tank. We shall not be liable for any damages caused by this reason.



Attention!

In order to reduce the possibilities of machine damage and prolong the life, start the machine with correct methods.



Attention!

Temperature setting value should not be lower than 5°C. Temperature of anti-freezing switch and high and low pressure switch is already set before delivery. We shall not be liable for any damage caused by unauthorized change of the setting.



Attention!

The compressor can't be started frequently because of its characteristics (Frequent start will shorten its service life.). Therefore, the compressor will work about 3 minutes later after turning on the water pump. The parameter of temperature controller shall not be adjusted freely since it is already set.

4.3 Machine Shutdown

1) Turn off the compressor.

- 2) Turn off the pump. (Better to wait for 30 seconds after the compressor shutdown to ensure that the refrigerant in the evaporator is completely evaporated.)
- 3) Turn off the main switch.



Attention!

Avoid electrical shock when main switch is turned on.



Attention!

In order to reduce the possibilities of machine damage and prolong the life, shut off the machine with correct methods.

4.4 Thermostat 1

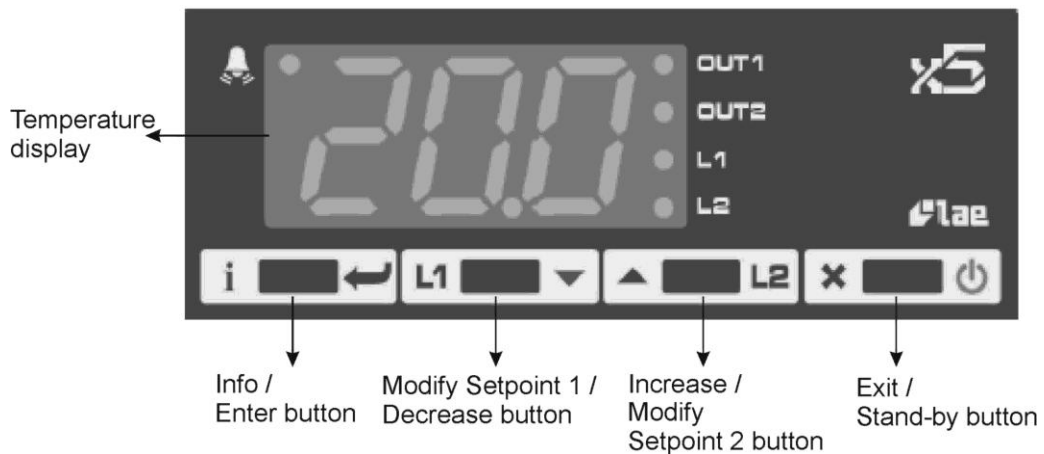

Picture 4-3: Thermostat

4.4.1 Temperature Setting

Limits of SPL and SPH for setting points exist in any condition and set through

◆+X to acquire values of SPL and SPH.



Attention!

Notices: all parameters must be reset when temperature unit changed.

4.4.2 Default Setting Table

Table 4-2: Default Setting (SIC-7.5A~38A-R2)

No.	Code	Meaning of parameters	Default value	Remark
1	1SP	Setting value of output 1	7	Unit: °C

Note: These parameters are only exclusive to AC1-5TSR2W-A.

Table 4-3: Default Setting (SIC-48A~114A-R2)

No.	Code	Meaning of parameters	Default value	Remark
1	1SP	Setting value of output 1	7	Unit: °C

Note: These parameters are only exclusive to AC1-5TSR2W-A and standard water chiller which don't equip with the hot gas bypass valve.

Table 4-4: Default Setting (SIC-48A~75A-R2)

No.	Code	Meaning of parameters	Default value	Remark
1	1SP	Set point of OUT1	7	Unit: °C

Note: These parameters are only exclusive to AC1-5TSR2W-A and water chiller which don't equip with the hot gas bypass valve.

When to setup, (user shall) continuously press $\blacklozenge+\times$ buttons for over 5 seconds at the same time. When adjustable parameter at first level appears, switch it to the setting of parameter at next level through pressing \blacktriangle button and return it to previous level by pressing button \blacktriangle . Press \blacklozenge button to display parameter value and press $\blacklozenge+\blacktriangle$ or $\blacklozenge+\blacktriangledown$ simultaneously to change values. Press \blacklozenge to confirm it and continue the next setting.

It will automatically quit parameter setting after 30S of no keyboard input.

4.4.3 Code Meanings

Table 4-5: Code Meaning

---	Power supply self-test status (3S)	E1	Autotuning time 1 error
5.4	Display of actual temperature	E2	Autotuning time 2 error
Or	Sensor breaks	E3	Autotuning failure
Tun/5.4	Process of PID autotuning	OFF	Controller standby

5. Trouble-shooting

Faults	The action of the protection units	The possible fault analysis	Solutions
1. No power supply display or phase reversal	The protection units have no action	<ul style="list-style-type: none"> A. The power supply is not switched on B. The fuse wire of the control loop is burned out C. The linear ordering of the power supply is in the reverse order D. The fault of the main switch or circuit 	<ul style="list-style-type: none"> A. Power on after checking B. Check the protection loop C. Change the wires in order of two random power supply wires D. Check or replace
2. Pump overload	The loader trips	<ul style="list-style-type: none"> A. Over current B. The fault of the pump C. The fault of the pump over loading controller 	<ul style="list-style-type: none"> A. Reset the over loader B. Replace after checked and repaired C. Replace after checked and repaired
3. Compressor overload	The loader trips	<ul style="list-style-type: none"> A. Over current B. The fault of the compressor C. The fault of the compressor over loading controller 	<ul style="list-style-type: none"> A. Reset the over loader B. Replace after checked and repaired C. Replace after checked and repaired
4. The high pressure is too high	The high pressure switch trips	<ul style="list-style-type: none"> A. The refrigerant is too much B. The amount of blast to the condenser is not enough C. The sediment incrustation of the condenser is too much D. The dry filter is blocked up E. The open scale of the expansion valve is too narrow F. The fault of the fan G. The fault of the high pressure switch I. The condenser is beaten by the sunshine 	<ul style="list-style-type: none"> A. Discharge some of the refrigerant B. Increase the amount of blast to the condenser C. Clean the condenser D. Clean the dry filter E. Adjust the open scale properly F. Replace after checked and repaired G.. Replace after checked and repaired H. Replace after checked and repaired I. Prevent the condenser from being beaten by the sunshine

Faults	The action of the protection units	The possible fault analysis	Solutions
5. The high pressure is too low	The protection units have no action	<ul style="list-style-type: none"> A. The refrigerant is not enough. B. The vanes of the compressor are spoiled C. Ambient temperature is too low 	<ul style="list-style-type: none"> A. Check the system pipeline and weld pipeline, add refrigerant. B. Replace after checked and repaired. C. Ward off part of the condenser to ensure high pressure above 27bar.
6. The low pressure is too low	The low pressure switch trips	<ul style="list-style-type: none"> A. The refrigerant is not enough B. The dry filter is blocked up C. The open scale of the expansion valve is too small D. The fault of the expansion valve E. The fault of the low pressure switch 	<ul style="list-style-type: none"> A. Check the system pipelines, weld pipelines, and supply refrigerant. B. Clean the dry filter C. Adjust the open scale properly D. Replace after checked and repaired E. Replace after checked and repaired
7. The low pressure is too high	The protection units have no action	<ul style="list-style-type: none"> A. The cooling load is too big B. The power of the compressor decreases C. The open scale of the expansion valve is too big D. The packed weight of the refrigerant is excessive 	<ul style="list-style-type: none"> A. Adjust the cooling load B. Replace after checked and repaired C. Adjust the open scale of the expansion valve D. Discharge some of the refrigerant
8. Compressor overheat	The protection units have no action	<ul style="list-style-type: none"> A. The heat degree of the refrigerant in the air return pipe is too high B. The high pressure is too high C. The low pressure is too low 	<ul style="list-style-type: none"> A. Adjust the open scale of the expansion valve properly B. Check, repair and improve C. Check, repair and improve

Faults	The action of the protection units	The possible fault analysis	Solutions
9. The chassis of the air return pipe and the compress or frost over	The protection units have no action	<ul style="list-style-type: none"> A. The open scale of the expansion valve is too small B. The refrigerant is too much C. The heat load is too small D. Bad efficiency of evaporator. 	<ul style="list-style-type: none"> A. Adjust the open scale of the expansion valve properly B. Check the system pipeline and weld pipeline, add refrigerant. C. Increase the heat load. D. Clean the evaporator.
10. The compressor can not start up or trips after starting up	The protection units have no action	<ul style="list-style-type: none"> A. The power supply wire is broken or the voltage is off normal B. The temperature control instrument is not set up properly C. The over loading protector is not reset 	<ul style="list-style-type: none"> A. Check and connect the wires according to Specifications B. Reset the temperature control instrument C. Reset the over loading protector
	The freeze protection switch trips	<ul style="list-style-type: none"> A. The amount of the ice water is too little and bring about that the water temperature is too low B. The temperature control is set too low or has some faults C. The freeze protection switch is not properly set or has some faults 	<ul style="list-style-type: none"> A. Check the pump and discharge the air in the water pipe B. Correct the set point or change C. Check, weld and repair
11. The cooling capacity can not get up to the standard		<ul style="list-style-type: none"> A. There is some air in the cooling system B. The water quantity and water supply in the cooling system is abnormal C. The fans run abnormally D. The filter is blocked up E. The configure of the cooling pump is not prope F. The cooling water pipe is not configured according to the standard. G. Bad efficiency of the evaporator and condenser. H. Expansion valve is blocked. I. Inaccurate refrigerant fillig. 	<ul style="list-style-type: none"> A. Discharge the air B. Control the water level of the water supply tank C. Check and repair D. Clean the filter E. Choose the pump up to the standard (flow quantity and delivery lift) F. Configure water pipe according to the standard G. Clean the evaporator and condenser. H. E. Replace after checked and repaired. I. Accurately supply the refrigerant.

6. Maintenance and Repair

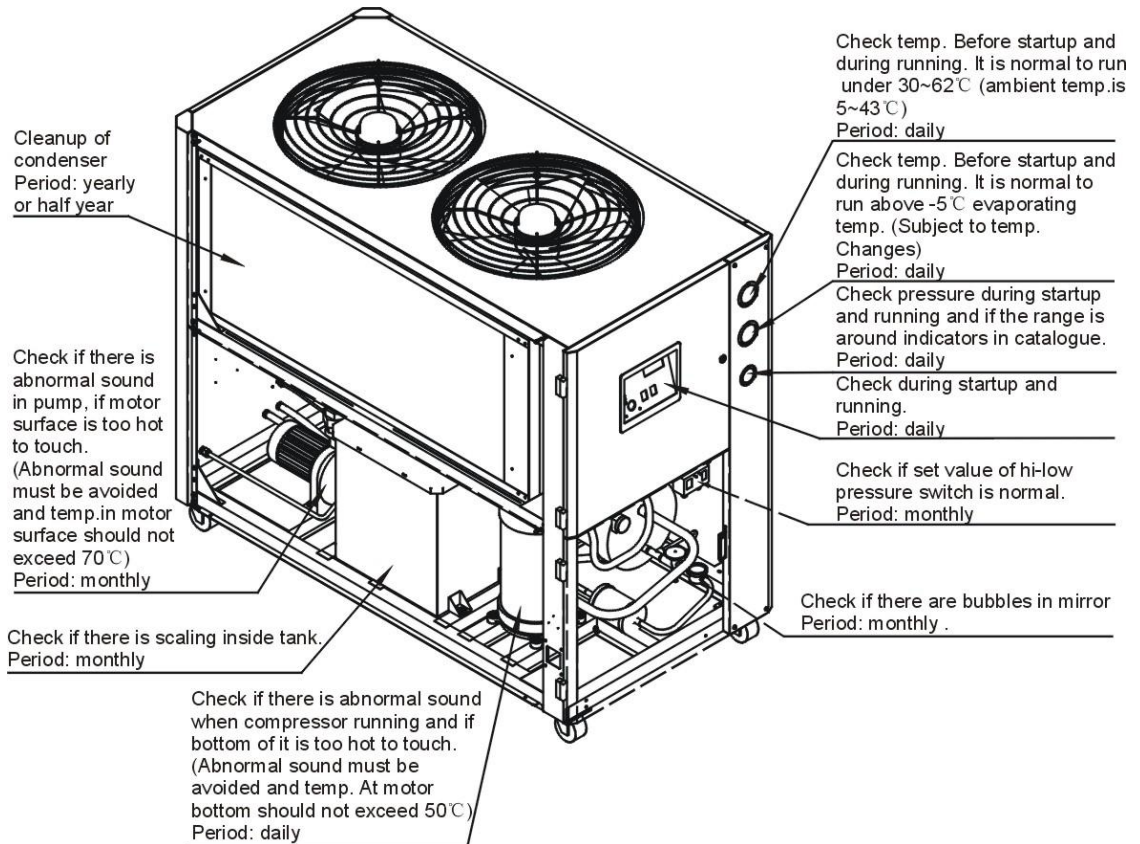

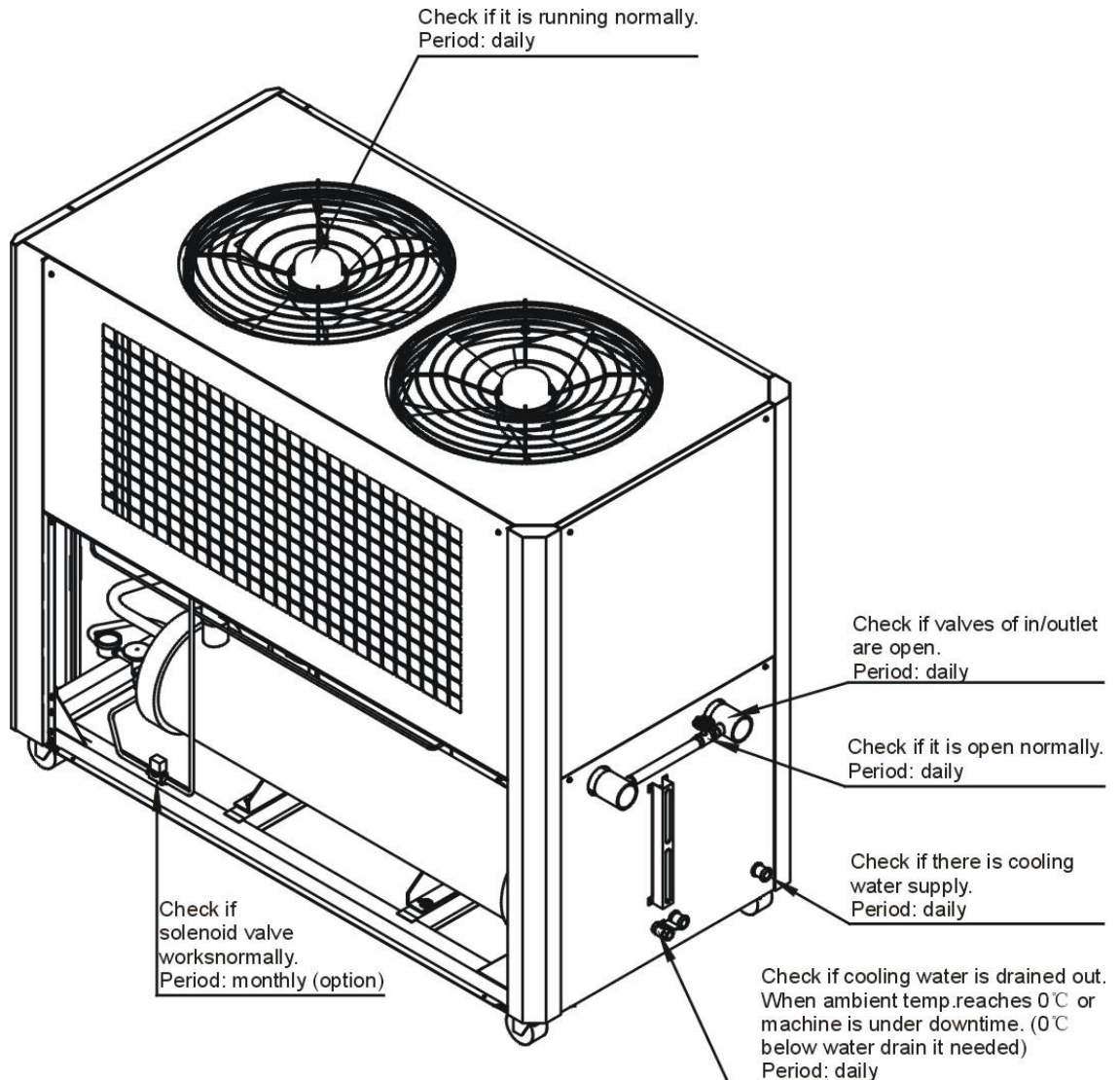

Attention!

All repair work should be done by qualified personnel only to avoid damage to the machine or personnel injury.

In order to operate the machine rightly and safely, please caution the matter follows:

- 1) Do not turn off the main power switch to stop the machine, except emergency situation.
- 2) When failures set in and the machine stop work with buzzer sound, first turn off the main power switch of the machine (alarm indicator will die), then go to

check the reason of the failures, do not force the machine on before remove the failures.

- 3) Please check periodically to prolong the life of the machine and prevent the safety accident to appear.
- 4) Water supply should be processed, because the high PH can corrode the copper pipe acute. This must reduce the life of the heating and cooling implement, PH of the water supply must be between 7.0~8.5.
- 5) Keep the machine room dry, clean and draughty.
- 6) The operation and service of the machine should be done by qualified technician only.

(Please take notice that the disassembly and the inspection of the machines are hazardous when the machines are running!)

6.1 Fill in the Refrigerant

- 1) Screw off the end cap of the liquid filling thimble valve, and connect the air suction pipe of the vacuum pump to the liquid filling thimble valve to take the vacuum pumping, and this process may take one to two hours. The high & low pressure gauge dispalys -76mmHg.

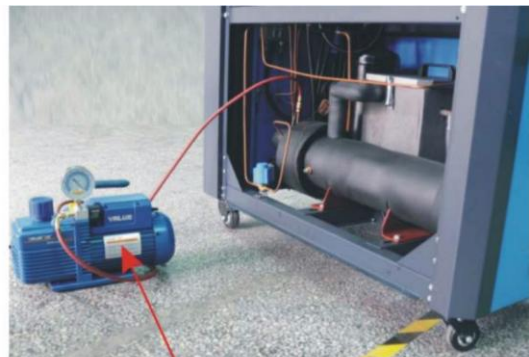
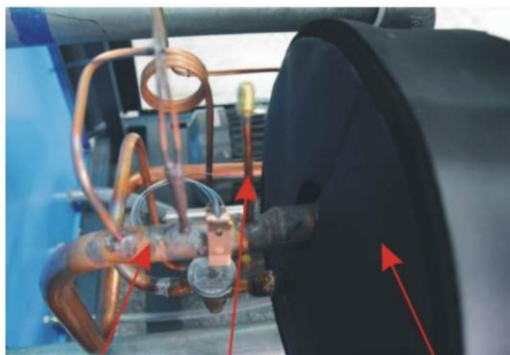

Return air pipe

Evaporator

Vacuum pump

End cap of the
liquid filling thimble
valve

Picture 6-1: Fill in the Refrigerant (1)

- 2) After the vacuum pumping, connect the air pipe of the refrigerant tank to the liquid filling thimble valve, and fill the refrigerant into the air return pipe. Watch the change of the weight displayed by the electronic scale, and stop filling the

refrigerant immediately when receiving the schedule weight. Make sure that the filling refrigerant must be liquid and be filled when the machine stops. In the condition of the starting up, the shown pressure of the high pressure gage should be about 29 to 31 bar; and shown pressure of the low pressure gage should be about 7 to 8 bar. (Note: the ambient temperature should be 35°C, and the temperature of the chilled water should be 12°C/7°C.)



Electronic Refrigerant tank scale

Picture 6-2: Fill in the Refrigerant (2)

Table 6-1: SIC-A-R2 Filling Quantity

Model	Filling Quantity of Refrigerant (kg)
SIC-7.5A-R2	3.5
SIC-12A-R2	5.0
SIC-18A-R2	5.5
SIC-24A-R2	5.5
SIC-28A-R2	9.0
SIC-38A-R2	12.5

6.2 Components Maintenance

6.2.1 Condenser

SIC-A-R2 series water chiller use the air cooled fin style condenser which installed openly, in the using time, it is hard to avoid any dust and sundries, which will influence the heat emission effect, so it is necessary to clean the condenser at fixed periods in order to keep its working performance. Use brush,

dust catcher or compressed air to clean the wings and copper pipe. Then use the low pressure water to cascade the tray pipe. Note: do not let the water to cascade on the surface of the fan motor.



Attention!

Do the cleaning work every half-year in the environment with little dust, but you must do the work every month in the environment with a great deal of dusts, and under the severe environment you had better see the situation to do the work.

6.2.2 Evaporator

The inner flank of the heat emission pipe will pile up a great deal of water incrustation after a long time use of the evaporator, which will influence the heat emission effect, so it is necessary to clean the evaporator at fixed periods in order to keep its working performance. If the circulation has been under water treatment, it is advised that firstly use hydrogen peroxide to kill bacteria and then use a high pressure water rifle to flush it, at last check whether there is still incrustation scale. If the circulation is not processed under water treatment, clean it with citric acid and sulfamic acid along with inhibitor, and then flush it with a high pressure water rifle. Passivation is need after acid washing, and the dirt will be discharged from the water outfall.



Attention!

Drain the water inside the evaporator and the condenser away when the machine stop running under 0°C.

6.3 Maintenance Schedule

6.3.1 About the Machine

Model _____ SN _____ Production date _____

Voltage _____ Φ _____ V Frequency _____ Hz

Total power _____ kW

6.3.2 Check after Installation

- Check the pipes are all correctly connected.
- Check if there are leakages in the piping system.
- Check if there are breaks in welding joint.

Electrical Installation

- Voltage: _____ V _____ Hz
- Fuse specification: 1 Phase _____ A 3 Phase _____ A
- Check phase sequence of power supply.

6.3.3 Daily Checking

- Check switch functions.
- Check all the electrical wires.
- Check whether pressure gauges are accurate.
- Check whether compressor temperature is normal.
- Check whether cooling water circulation is normal.

6.3.4 Weekly Checking

- Check electrical connections.
- Check protection & alarm function.
- Check whether set point of hi-low pressure switch is normal.

6.3.5 Montly Checking

- Check refrigerant circulation pipe.
- Check whether there are bubbles in liquid indicator.
- Check whether there is abnormal sound in pump.
- Check whether there is scale formation in tank.

6.3.6 Trimonthly Checking

- Check whether condenser is under blockage.

6.3.7 Half-yearly Checking

- Check and clean the condenser and evaporator.
- Check and clean the filter and expansion valve.
- Check system performance.
- Clean condenser.

6.3.8 Yearly Checking

- Check whether the contactor is normal.

6.3.9 3 year Checking

- PC board renewal.
- No fuse breaker renewal.