

SSM-U Series

Storage Mixers

Date: Mar, 2018

Version: Ver.D (English)



Contents

1. General Description	5
1.1 Coding Principle	6
1.2 Feature	6
1.3 Technical Specifications.....	8
1.3.1 Technical Specifications	8
1.3.2 Specifications	8
1.4 Safety Regulations	9
1.4.1 Safety Signs and Labels	9
1.4.2 Transportation and Storage of the Machine.....	9
1.5 Exemption Clause	11
2. Structure Characteristics and Working Principle	12
2.1 Working Principle	12
2.1.1 Timer	13
3. Installation and Debugging.....	14
3.1 Install the Machine on a Water-level Floor	14
3.2 Installation Space	14
3.3 Installation of Motor	15
3.4 Installation of Blending Vanes	15
3.5 Power Connection	15
4. Application and Operation.....	16
4.1 Description of Control Panel	16
4.2 Control Panel Description	16
4.3 Start/stop of the Machine	16
4.4 Operation Guide.....	17
5. Trouble-shooting	18
6. Maintenance and Repair	19
6.1 Service	19
6.2 Maintenance	19
6.2.1 Maintenance of Blending Motor	19

6.2.2	Maintenance of Blending Barrel and Blending Screw	19
6.3	Maintenance Schedule.....	20
6.3.1	About the Machine.....	20
6.3.2	Check after Installation	20
6.3.3	Daily Checking.....	20
6.3.4	Weekly Checking.....	20
6.3.5	Monthly Checking	20

Table Index

Table 1-1:	Specifications.....	8
------------	---------------------	---

Picture Index

Picture 1-1:	Technical Specifications	8
Picture 2-1:	Working Principle Illustration.....	12
Picture 2-2:	Timer.....	13
Picture 3-1:	Install the Machine on a Water-level Floor.....	14
Picture 3-2:	Installation Space	15
Picture 4-1:	Description of Control Panel	16

1. General Description



Read this manual before installation and using of the machine to prevent personal injuries and damage of the machine.

SSM-U is mainly used for mixing plastics as raw materials, masterbatch and recycled materials. SSM-U can not be used dealing with plastic powder and all kinds of foods, chemicals, and inflammable, explosive and volatile materials. Bulk density should be taken into account when the dimension of material is uneven or in other forms.



Model: SSM-160U

1.1 Coding Principle

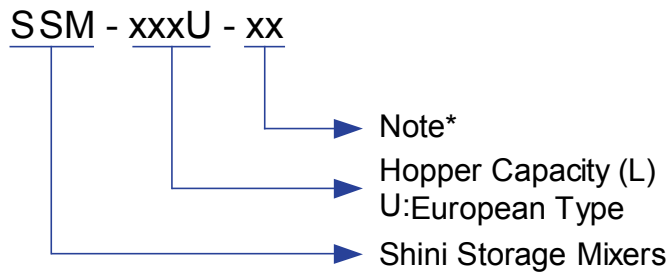

Note*
CE=CE Conformity

1.2 Feature

1) Standard configuration

- Vertically mounted blending screw and cylinder ensure even mixing of materials.
- Removable top assembly (lid, motor, and control box) for easy cleaning.
- 0~300 hours auto-stop function.
- Equipped with main power switch and safety interlock protective device to ensure operator's safety and no damage to the machine.
- SSM has height adjustable stand and castors with brake are standard accessories for easy transportation.

2) Accessory option

- Pneumatic slide gate is an optional accessory for mounting at discharge outlet.

All service work should be carried out by a person with technical training or corresponding professional experience. The manual contains instructions for both handling and servicing. Chapter 7, which contains service instructions intended for service engineers. Other chapters contain instructions for the daily operator.

Any modifications of the machine must be approved by SHINI in order to avoid personal injury and damage to machine. We shall not be liable for any damage caused by unauthorized change of the machine.

Our company provides excellent after-sales service. Should you have any problem during using the machine, please contact the company or the local vendor.

Headquarter and Taipei factory:

Tel: (886) 2 2680 9119

Shini Plastics Technologies (Dongguan), Inc:

Tel: (86) 769 8111 6600

Shini Plastics Technologies India Pvt.Ltd.:

Tel: (91) 250 3021 166

1.3 Technical Specifications

1.3.1 Technical Specifications

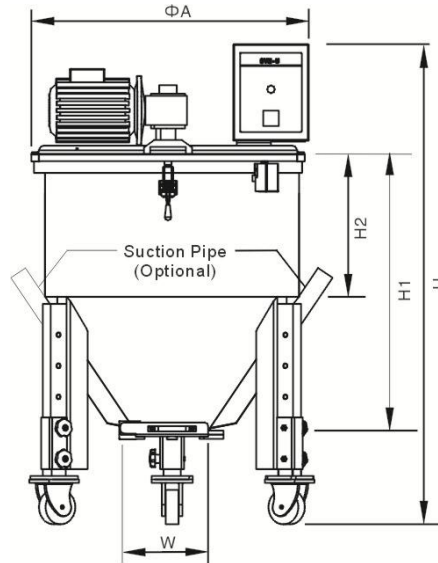

Picture 1-1: Technical Specifications

1.3.2 Specifications

Table 1-1: Specifications

Model	SSM-80U	SSM-160U	SSM-300U
Ver.	D	B	C
Motor Power (kW)	0.55	0.55	1.1
Processing Capacity (kg/hr)	200	400	800
Blending Barrel (L) *	80	160	300
Dimensions			
H (mm)	1550	1605	1835
H1 (mm)	600	850	1000
H2 (mm)	300	400	500
W (mm)	140	200	200
ΦA (mm)	750	900	1100
Weight (kg)	83	126	187

Notes: 1) "*" stands for the optimal mixing time when it is full load is about 15min.

2) Max. noise level is 70dB (A).

3) Max. mixing capacity is tested based on continuous processing material of 0.65kg/L in bulk density and 2~3mm in size.

4) Power 3 Φ , 230 / 400 / 460 / 575VAC, 50 / 60Hz.

We reserve the right to change specifications without prior notice.

1.4 Safety Regulations

Strictly abide by the following safety regulations to prevent damage of the machine or personal injuries.

1.4.1 Safety Signs and Labels



All the electrical components should be installed by qualified electricians.
Turn off the main switch and control switch during maintenance or repair.



Warning! High voltage!

This sign is attached on the cover of control box!



Warning! Be careful!

Be more careful at the place where this sign appears!



Attention!

No need for regular inspection because all the electrical parts in the control unit are fixed tightly!

1.4.2 Transportation and Storage of the Machine

Transportation

- 1) SSM-U series vertical batch mixers are packed in crates or plywood cases with wooden pallet at the bottom, suitable for quick positioning by fork lift.
- 2) After unpacked, castors equipped on the machine can be used for ease of movement.
- 3) Do not rotate the machine and avoid collision with other objects during transportation to prevent improper functioning.
- 4) The structure of the machine is well-balanced, although it should also be handled with care when lifting the machine for fear of falling down.
- 5) The machine and its attached parts can be kept at a temperature from -25°C to $+55^{\circ}\text{C}$ for long distance transportation and for a short distance, it can be transported with temperature under $+70^{\circ}\text{C}$.

Storage

- 1) SSM-U series vertical batch mixers should be stored indoors with temperature kept from 5°C to 40°C and humidity below 80%.
- 2) Disconnect all power supply and turn off main switch and control switch.
- 3) Keep the whole machine, especially the electrical components away from water to avoid potential troubles caused by the water.
- 4) Plastic film should be used to protect the machine from dust and rains.

The machine should be operated:

- 1) Indoors in a dry environment with max. temperature +45°C and humidity no more than 80%.

Do not use the machine:

- 1) If it is with a damaged cord.
- 2) On a wet floor or when it is exposed to rain to avoid electrical shock.
- 3) If it has been dropped or damaged until it is checked or fixed by a qualified serviceman.
- 4) This equipment works normally in the environment with altitude within 3000m.
- 5) At least a clearance of 1m surrounding the equipment is required during operation. Keep this equipment away from flammable sources at least two meters.
- 6) Avoid vibration, magnetic disturbance at the operation area.

Rejected parts disposal

When the equipment has run out its life time and can not be used any more, unplug the power supply and dispose of it properly according to local code.

Fire hazard



In case of fire, CO₂ dry powder fire extinguisher should be applied.

1.5 Exemption Clause

The following statements clarify the responsibilities and regulations born by any buyer or user who purchases products and accessories from Shini (including employees and agents).

Shini is exempted from liability for any costs, fees, claims and losses caused by reasons below:

1. Any careless or man-made installations, operation and maintenances upon machines without referring to the Manual prior to machine using.
2. Any incidents beyond human reasonable controls, which include man-made vicious or deliberate damages or abnormal power, and machine faults caused by irresistible natural disasters including fire, flood, storm and earthquake.
3. Any operational actions that are not authorized by Shini upon machine, including adding or replacing accessories, dismantling, delivering or repairing.
4. Employing consumables or oil media that are not appointed by Shini.

2. Structure Characteristics and Working Principle

To achieve the aim of mixing material, screw blades are used to generate vortex. Materials are sucked towards mixing screws at the center of hopper bottom by vortex, then materials whirl upward to the top and fall down so that the evenly mixing can be fulfilled in a short period.

2.1 Working Principle

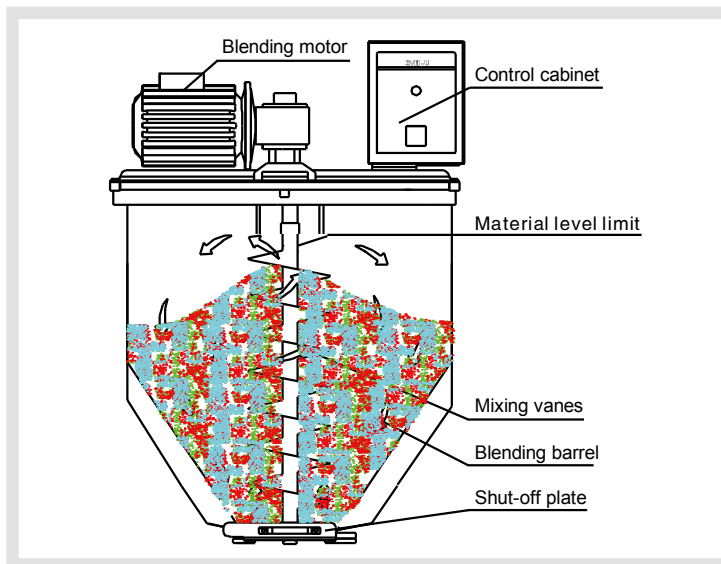

Picture 2-1: Working Principle Illustration

Signals from the control cabinet will be sent to blending motor which drives the blending screw to start material blending. Then material conveyed along the cylinder up to the top is evenly spread in the blending barrel. This process mixes material evenly in a short time, saving energy. After blending, draw open the shut-off plate to discharge the material.

2.1.1 Timer



Picture 2-2: Timer

Function Description:

1. Adjusting scale.
2. Choose sec/min/hrs/10h as a time unit by turning this button.

3. Installation and Debugging

Before installation, read this chapter carefully. Install the machine according to following steps!

Note: Power supply of the mixer should be connected by qualified electricians!

3.1 Install the Machine on a Water-level Floor

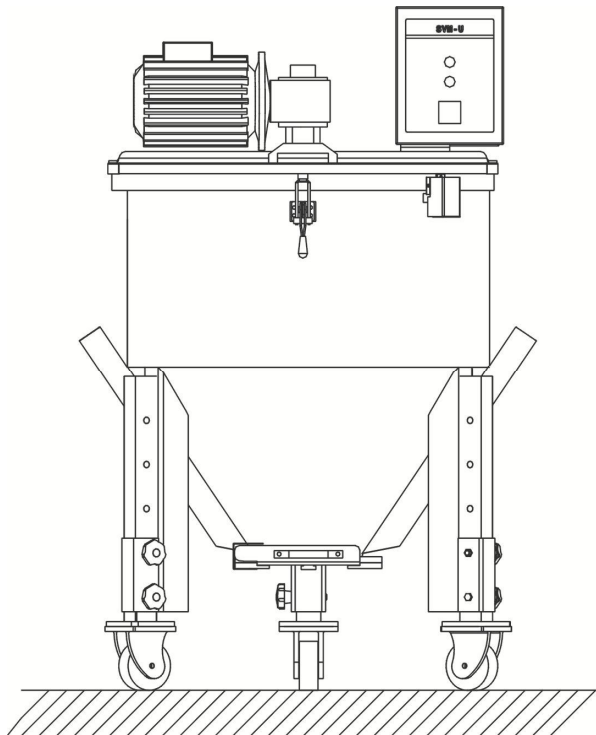

Picture 3-1: Install the Machine on a Water-level Floor

Vertical batch mixer should be placed on a water-level floor with castors locked, ensuring the machine well-balanced and no vibration.

3.2 Installation Space

Keep at least 500mm space around the machine when installing it. As the following figure shows: Do not install the machine in a narrow space, because this will make it uneasy to repair or maintenance. Do not sit on the top of the machine or place any inflammable objects around the machine.



Picture 3-2: Installation Space

3.3 Installation of Motor

Do not enforce any force on the output parts of decelerate motor or case. Please meet the machine and gear motor's respective requirement for concentricity or verticality.

3.4 Installation of Blending Vanes

Please meet the blending screw and gear motor's respective requirement for concentricity or verticality when install the machine.

3.5 Power Connection

Connect the control box of the vertical batch mixer to power line and earth wire as indicated by the nameplate. Usually adopts 3 Φ 400V power supply and it can be also made on customer's special demand.



Check the motor's running direction after connects to power, if it is running reversely, please cut off the power and transpose any two lines of the three lines from the main power.(warning: reverse running is not allowed when the machine is in operation otherwise it will cause obstruction and lead to motor damage)

4. Application and Operation

4.1 Description of Control Panel

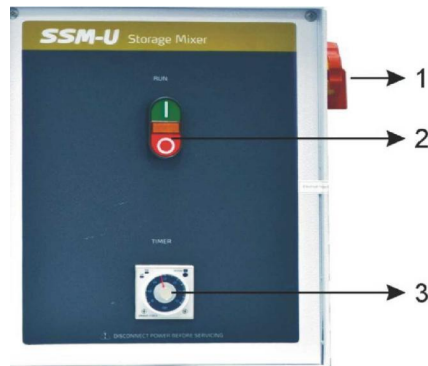

Picture 4-1: Description of Control Panel

4.2 Control Panel Description

No.	Name	Function Description	Remarks
1	Main power	Main power switch of the control system.	
2	System run	Start/stop of blending motor.	Red for stop and green for start.
3	Auto-timer	Timer for auto-stop after set material blending time.	When system is turned on, use the timer to set motor blending time after which the machine will stop working automatically.

4.3 Start/stop of the Machine

- 1) Check power supply is turned on.
- 2) Turn on the main switch on control panel.
- 3) Press the green button to start material blending.
- 4) Use the red button to stop the machine, and main power switch to cut off power supply.

4.4 Operation Guide

- 1) Open blending barrel lid, fill in materials.

Note: material level should not higher than the top opening of the cylinder..

- 2) Close blending barrel lid, plug in safety switch and fasten the snap hook.

Note: tightly close the blending barrel lid to secure safety switch, or the machine cannot be started.

- 3) Turn on main power switch on the control panel.

- 4) Press the green button on control panel to start the machine.

- 5) Turn the adjusting scale of the timer if needed to set material blending time.
The machine will stop working automatically after set time.

- 6) Press the stop button to stop material mixing after the material is evenly mixed if the timer is not set for automatic stop.

5. Trouble-shooting

Failures	Solutions
After turning on main power and pressing down green system run button, the indicator cannot turn bright, motor does not work.	Check the electrical circuit, the reasons may be: <ol style="list-style-type: none"> 1. Electrical wire break. 2. Fuse melted. 3. The shut-off plate for Blending barrel lid not closed or safety switch not fully connected. 4. Material blending time is set to 0. If motor can work, but indicator cannot turn bright, it shows that the indicator is broken. If indicator turns bright, but motor can not work, this may caused by motor failures or solenoid valve problems.
Machine cannot stop after setting time.	Check the electrical circuit, the reasons may be: <ol style="list-style-type: none"> 1. The timer is broken. 2. Electrical wire problems.
Overload relay frequently tripping off.	Check the electrical circuit, the reason can be: <ol style="list-style-type: none"> 1. Adjust overload relay setting current <ol style="list-style-type: none"> 1.1 times of motor rated current. 2. Wires of solenoid valve short circuit or break. 3. Overload relay is burnt out. 4. Motor problems. 5. Motor runs reversely.
Cannot stop the working of material blending by pressing the stop button.	The contact of stop button may be stuck together. If so, please replace the stop button.
Materials can not be well mixed, although no problems with machine start and stop function.	Material mixing time not enough, increase material mixing time.

Motor overload

Motor overload will cause overload relay to trip off, which stops working of the motor. Switch position is indicated by a pin (blue)(A) projecting at the front plate. Press "Reset" button to reset the relay. Please refer to chapter 2.3.3 has details.



6. Maintenance and Repair

6.1 Service

All the repair work should be done by qualified technicians to prevent personal injuries and damage of the machine.

6.2 Maintenance

6.2.1 Maintenance of Blending Motor

Replace the lubricating oil of the gear motor after first 400 hours running. After that, replace the lubricating oil at about every 4000 hours. Check on times that there's enough lubricant in the gear box. Add or replace the lubricant before oil used up or when oil is turned bad. Keep motor and gear box covers clean from dusts or dirt's for quick cooling.

6.2.2 Maintenance of Blending Barrel and Blending Screw

Disassemble blending barrel lid, motor, blending screw, and control box; use a piece of soft cloth to clean blending barrel from material remains.

Note: Turn off the main switch and control switch before repairing or maintenance.

6.3 Maintenance Schedule

6.3.1 About the Machine

Model _____ SN _____ Manufacture date _____

Voltage _____ Φ _____ V Frequency _____ Hz Power _____ kW

6.3.2 Check after Installation

- Check the machine is installed on a water-level floor.
- Check the installation of the motor.
- Check the safety switch of blending barrel.

Electrical Installation

- Power supply: _____ V _____ Hz
- Fuse melt current: 1 Φ _____ A 3 Φ _____ A
- Check the electrical wire connections of the control.

6.3.3 Daily Checking

- ____ / ____ / ____
- Check the main power switch
 - Check system start button
 - Check the safety switch

6.3.4 Weekly Checking

- ____ / ____ / ____
- Check all the electrical wires
 - Check motor overload protection function

6.3.5 Monthly Checking

Replace the lubricating oil of the gear motor after first 400 hours running. After that, replace the lubricating oil at about every 4000 hours. Check on times that there's enough lubricant in the gear box. Add or replace the lubricant before oil is used up or when the oil is turned bad.